

Multi-channel Modular Power System

IT2705 User Manual



Model: IT2705

Version: V2.1/4,2026

Notices

© Itech Electronic, Co., Ltd. 2026

No part of this manual may be reproduced in any form or by any means (including electronic storage and retrieval or translation into a foreign language) without prior permission and written consent from Itech Electronic, Co., Ltd. as governed by international copyright laws.

Manual Part Number

IT2705

Revision

2nd Edition: Apr. 18, 2026

Itech Electronic, Co., Ltd.

Trademarks

Pentium is U.S. registered trademarks of Intel Corporation.

Microsoft, Visual Studio, Windows and MS Windows are registered trademarks of Microsoft Corporation in the United States and/or other countries and regions.

Warranty

The materials contained in this document are provided “as is”, and is subject to change, without prior notice, in future editions. Further, to the maximum extent permitted by applicable laws, ITECH disclaims all warranties, either express or implied, with regard to this manual and any information contained herein, including but not limited to the implied warranties of merchantability and fitness for a particular purpose. ITECH shall not be held liable for errors or for incidental or indirect damages in connection with the furnishing, use or application of this document or of any information contained herein. Should ITECH and the user enter into a separate written agreement with warranty terms covering the materials in this document that conflict with these terms, the warranty terms in the separate agreement shall prevail.

Technology Licenses

The hardware and/or software described herein are furnished under a license and may be used or copied only in accordance with the terms of such license.

Restricted Rights Legend

Restricted permissions of the U.S. government. Permissions for software and technical data which are authorized to the U.S. Government only include those for custom provision to end users. ITECH provides this customary commercial license in software and technical data pursuant to FAR 12.211 (Technical Data) and 12.212 (Computer Software) and DFARS 252.227-7015 (Technical Data – Commercial Items) and DFARS 227.7202-3 (Rights in Commercial Computer Software or Computer Software Documentation).

Safety Notices

CAUTION

A CAUTION sign denotes a hazard. It calls attention to an operating procedure or practice that, if not correctly performed or adhered to, could result in damage to the product or loss of important data. Do not proceed beyond a CAUTION sign until the indicated conditions are fully understood and met.

WARNING

A WARNING sign denotes a hazard. It calls attention to an operating procedure or practice that, if not correctly performed or adhered to, could result in personal injury or death. Do not proceed beyond a WARNING sign until the indicated conditions are fully understood and met.



NOTE

A NOTE sign denotes important hint. It calls attention to tips or supplementary information that is essential for users to refer to.

Quality Certification and Assurance

We certify that IT2700 series power supply meets all the published specifications at time of shipment from the factory.

Warranty

ITECH warrants that the product will be free from defects in material and workmanship under normal use for a period of one (1) year from the date of delivery (except those described in the Limitation of Warranty below).

For warranty service or repair, the product must be returned to a service center designated by ITECH.















- The product returned to ITECH for warranty service must be shipped PREPAID. And ITECH will pay for return of the product to customer.
- If the product is returned to ITECH for warranty service from overseas, all the freights, duties and other taxes shall be on the account of customer.

Limitation of Warranty

This Warranty will be rendered invalid if the product is:

- Damaged resulting from customer-wired circuits or customer-supplied parts or accessories;
- Modified or repaired by customer without authorization;
- Damaged resulting from customer-wired circuits or use in an environment not designated by us;
- The product model or serial number is altered, deleted, removed or made illegible by customer;
- Damaged as a result of accidents, including but not limited to lightning, moisture, fire, improper use or negligence.

Safety Symbols

	Direct current		ON (power)
	Alternating current		OFF (power)
	Both direct and alternating current		Power-on state
	Chassis (earth ground) symbol.		Power-off state
	Earth (ground) terminal		Reference terminal
	Caution		Positive terminal
	Warning (refer to this manual for specific Warning or Caution information)		Negative terminal

	A chassis terminal	-	-
---	--------------------	---	---

Safety Precautions

The following safety precautions must be observed during all phases of operation of this instrument. Failure to comply with these precautions or specific warnings elsewhere in this manual will constitute a default under safety standards of design, manufacture and intended use of the instrument. ITECH assumes no liability for the customer's failure to comply with these precautions.

WARNING

- **Do not use the instrument if it is damaged. Before operation, check the casing to see whether it cracks. Do not operate the instrument in the presence of inflammable gasses, vapors or dusts.**
- **The instrument is provided with a power cord during delivery and should be connected to a socket with a protective earth terminal, a junction box or a three-phase distribution box. Before operation, be sure that the instrument is well grounded.**
- **Check all marks on the instrument before connecting the instrument to power supply.**
- **Use electric wires of appropriate load. All loading wires should be capable of bearing maximum short-circuit of electronic load without overheating. If there are multiple loads, each pair of the load power cord must be carry out the full rated short-circuit output current of the power securely.**
- **Ensure the voltage fluctuation of mains supply is less than 10% of the working voltage range in order to reduce risks of fire and electric shock.**
- **Do not install alternative parts on the instrument or perform any unauthorized modification.**
- **Do not use the instrument if the detachable cover is removed or loosen.**
- **To prevent the possibility of accidental injuries, be sure to use the power adapter supplied by the manufacturer only.**
- **We do not accept responsibility for any direct or indirect financial damage or loss of profit that might occur when using the instrument.**
- **This instrument is used for industrial purposes, do not apply this product to IT power supply system.**
- **Never use the instrument with a life-support system or any other equipment subject to safety requirements.**

WARNING

- **SHOCK HAZARD Ground the Instrument.** This product is provided with a protective earth terminal. To minimize shock hazard, the instrument must be connected to the AC mains through a grounded power cable, with the ground wire firmly connected to an electrical ground (safety ground) at the power outlet or distribution box. Any interruption of the protective

(grounding) conductor or disconnection of the protective earth terminal will cause a potential shock hazard that could result in injury or death.

- Before applying power, verify that all safety precautions are taken. All connections must be made with the instrument turned off, and must be performed by qualified personnel who are aware of the hazards involved. Improper actions can cause fatal injury as well as equipment damage.
- **SHOCK HAZARD, LETHAL VOLTAGES** This product can input the dangerous voltage that can cause personal injury, and the operator must always be protected from electric shock. Ensure that the input electrodes are either insulated or covered using the safety covers provided, so that no accidental contact with lethal voltages can occur.
- Never touch cables or connections immediately after turning off the instrument. Verify that there is no dangerous voltage on the electrodes or sense terminals before touching them.

CAUTION

- **Failure to use the instrument as directed by the manufacturer may render its protective features void.**
- **Always clean the casing with a dry cloth. Do not clean the internals.**
- **Make sure the vent hole is always unblocked.**

Environmental Conditions

The instrument is designed for indoor use and an area with low condensation. The table below shows the general environmental requirements for the instrument.



Environmental Conditions	Requirements
Operating temperature	0°C~40°C
Operating humidity	20%~80%(non-condensation)
Storage temperature	-10°C~70 °C
Altitude	Operating up to 2,000 meters
Installation category	II
Pollution degree	Pollution degree 2



Note

To make accurate measurements, allow the instrument to warm up for 30 min.

Regulatory Markings

	The CE mark indicates that the product complies with all the relevant European legal directives. The specific year (if any) affixed refers to the year when the design was approved.
	The instrument complies with the WEEE Directive (2002/96/EC) marking requirement. This affix product label indicates that you must not discard the electrical/electronic product in domestic household waste.

	<p>This symbol indicates the time period during which no hazardous or toxic substances are expected to leak or deteriorate during normal use. The expected useful life of the product is 10 years. The product can be used safely during the 10-year Environment Friendly Use Period (EFUP). Upon expiration of the EFUP, the product must be immediately recycled.</p>
---	--

Waste Electrical and Electronic Equipment (WEEE) Directive



2002/96/EC Waste Electrical and Electronic Equipment (WEEE) Directive

This product complies with the WEEE Directive (2002/96/EC) marking requirement. This affix product label indicates that you must not discard the electrical/electronic product in domestic household waste.

Product Category

With reference to the equipment classifications described in the Annex 1 of the WEEE Directive, this instrument is classified as a "Monitoring and Control Instrument".

To return this unwanted instrument, contact your nearest ITECH office.

Compliance Information

Complies with the essential requirements of the following applicable European Directives, and carries the CE marking accordingly:

- Electromagnetic Compatibility (EMC) Directive 2014/30/EU
- Low-Voltage Directive (Safety) 2014/35/EU

Conforms with the following product standards:

EMC Standard

IEC 61326-1:2012/ EN 61326-1:2013 ¹²³

Reference Standards

CISPR 11:2009+A1:2010/ EN 55011:2009+A1:2010 (Group 1, Class A)

IEC 61000-4-2:2008/ EN 61000-4-2:2009

IEC 61000-4-3:2006+A1:2007+A2:2010/ EN 61000-4-3:2006+A1:2008+A2:2010

IEC 61000-4-4:2004+A1:2010/ EN 61000-4-4:2004+A1:2010

IEC 61000-4-5:2005/ EN 61000-4-5:2006

IEC 61000-4-6:2008/ EN 61000-4-6:2009

IEC 61000-4-11:2004/ EN 61000-4-11:2004

1. The product is intended for use in non-residential/non-domestic environments. Use of the product in residential/domestic environments may cause electromagnetic interference.
2. Connection of the instrument to a test object may produce radiations beyond the specified limit.
3. Use high-performance shielded interface cable to ensure conformity with the EMC standards listed above.

Safety Standard

IEC 61010-1:2010/ EN 61010-1:2010

Content

Quality Certification and Assurance	i
Warranty	i
Limitation of Warranty	i
Safety Symbols	i
Safety Precautions.....	ii
Environmental Conditions.....	iii
Regulatory Markings	iii
Waste Electrical and Electronic Equipment (WEEE) Directive	iv
Compliance Information	v
Chapter1 Quick Reference	9
1.1 Brief Introduction	9
1.2 Front Panel Overview	10
1.3 Keyboard Introduction	11
1.3.1 Function Keys	11
1.3.2 Push-on Knob	12
1.3.3 Composite key	12
1.3.4 Oscilloscope Adjustment Keys	13
1.3.5 Setting Display Layout.....	14
1.4 Rear Panel Overview	15
1.5 View Instrument Identification	15
Chapter2 Inspection and Installation	17
2.1 Unpacking and Transportation.....	17
2.2 Verifying the Shipment.....	18
2.3 Instrument Size Introduction	19
2.4 Installing the Instrument.....	20
2.4.1 Power Module Installation	20
2.4.2 Disassembly module.....	22
2.4.3 Install the battery.....	23
2.5 Connecting the Power Cord	24
2.6 Connecting Test Lines (Optional).....	25
2.7 Remote Control	28
2.7.1 USB Interface.....	28
2.7.2 LAN Interface.....	29
2.7.3 CAN Interface	30
Chapter3 Getting Start.....	32
3.1 Power-on the Instrument.....	32
3.2 Meter View.....	34
3.2.1 View Introduction.....	34
3.2.2 Menu Interface.....	35
3.2.3 Introduction to Interface Symbols.....	36
3.3 Select the Channel	37
3.4 Set Parameters	37
3.5 Using the Front Panel Menu	37
3.6 Config Menu.....	38
3.6.1 Source Config Menu	38
3.6.2 Load Config Menu	40
3.6.3 SMU Config Menu	41
3.7 System Menu.....	44
3.8 On/Off Control	48
Chapter4 Operation and Application	50
4.1 Select Source Operation Mode	50
4.2 Select Load Operation Mode	51
4.3 Selecting SMU Operation Mode.....	55

4.3.1 Multi-Quadrant Power Supply	55
4.3.2 Range Selection.....	57
4.3.3 Output Bandwidth.....	57
4.3.4 Load Modes.....	57
4.4 Config Menu Function.....	59
4.4.1 Setting Output Rise Time/Fall Time.....	59
4.4.2 Set the Internal Resistance (Source/SMU Module Support).....	59
4.4.3 CR Function in Sink Mode (Bi-directional Module Support)	59
4.4.4 Setting the Power Relay Lock Status(Source Module Support)	60
4.4.5 Output Turn Off Mode (SMU Module Support)	61
4.4.6 Under Voltage Inhibit (Load Module Support).....	61
4.4.7 Short-circuit Analog Function (Load Module Support).....	61
4.5 Protection Function.....	61
4.5.1 Over Voltage Protection (OVP).....	63
4.5.2 Over Current Protection (OCP)	63
4.5.3 Over Power Protection (OPP)	64
4.5.4 Under Current Protection (UCP)	64
4.5.5 Under Voltage Protection (UVP).....	64
4.5.6 Over Temperature Protection (OTP).....	65
4.5.7 foldback protection	65
4.5.8 Sense Protection.....	66
4.6 Timing Output Function	66
4.7 Channel Synchronized Output Function.....	67
4.8 Parallel of Channels in the Main Frame	68
Chapter5 Generating Arbitrary Waveforms.....	70
5.1 LIST.....	70
5.1.1 Create a New List file	70
5.1.2 Open /Run List.....	72
5.1.3 Import/Export List File.....	72
5.2 Generating Arbitrary Waveforms (ARB)	73
5.2.1 Run the Arb Waveform.....	73
5.2.2 Setting the Arb Waveform Common Parameters.....	73
5.2.3 Configuring Step Arbs.....	74
5.2.4 Configuring Ramp Arbs	75
5.2.5 Configuring Staircase Arbs	76
5.2.6 Configuring Sine Arbs.....	77
5.2.7 Configuring Pulse Arbs	78
5.2.8 Configuring Trapezoid Arbs	79
5.2.9 Configuring Exponential Arbs.....	80
5.2.10 Configuring User-Defined Arbs.....	81
5.3 Configuring an Arb Sequence (ARB Sequence)	83
5.4 Configuring Constant-Dwell Arbs	86
5.5 Sine Sweep Waveform.....	87
5.6 Battery Simulation Function.....	88
5.7 Battery Charging Test Function	91
5.8 Battery Discharging Test Function.....	93
5.9 Dynamic Functions (Load module support)	96
Chapter6 Using the Measurement Function	99
6.1 Meter Function	99
6.2 Instrument measurement settings.....	100
6.2.1 Remote Measurement Function.....	101
6.2.2 Setting sampling mode	101
6.2.3 Whour & Ahour measurement.....	101
6.2.4 Select measurement range (SMU module support).....	101
6.3 Scope Function.....	101
6.4 Data logging function	102

6.5 Electrochemical Impedance Spectroscopy (SMU module support)	104
Chapter7 System-Related Functions	108
7.1 Setting System General Parameters	108
7.2 Setting Instrument General Function	109
7.3 Setting Communication	109
7.4 Screen Lock Function	110
7.5 Switching Local/Remote Mode	110
7.6 Save and Recall Operations	110
7.7 Screen Capture Function	111
7.8 Query the System Log	111
7.9 Query the System Information	111
7.10 System Management Functions	111
7.11 Digital I/O Function	112
Chapter8 Technical Specifications	117
8.1 Supplemental characteristics	117
8.2 Main technical parameters	117
<i>IT2705 Main frame specifications</i>	117
IT27814	118
IT27814E	120
IT27134	121
IT27135	123
IT27137	125
IT27154	127
IT27155	129
IT27157	131
IT27334	132
IT27335	134
IT27337	136
IT27354	139
IT27355	141
IT27357	143
IT27534	145
IT27535	146
IT27537	147
IT27554	149
IT27555	151
IT27557	153

Chapter1 Quick Reference

This chapter introduces the front and rear panels of the IT2705 series multi-channel power system to ensure that you can quickly understand the appearance, structure, and wiring of the power system and other usage functions before operating the power system, which will help you to better use this series of instruments.

1.1 Brief Introduction

IT2705 is a highly integrated modular DC power analysis platform designed for battery testing, developed based on extensive research on power sources. It combines DC power, electronic loads and arbitrary waveform generator with an intuitive GUI, supports Oscilloscope Sampling and Data Logging function, allowing for the creation of complex testing without the need for secondary development.

The IT2705 supports a variety of functional modules, including DC power modules, bidirectional power supply modules, regenerative loads, and SMU modules, with a power range from 20W to 500W, and can be configured with up to 8 channels. It can be applied for testing IoT devices, chips, automotive electronics, smart wearable devices, etc. It helps engineers deeply analyze dynamic waveforms, instant responses, and key electrical characteristics, improving testing efficiency and accuracy.

Features

- Supports more than 30+ modules (including DC sources, electronic loads, bidirectional power supply, SMU).
 - Up to 8 modules can be installed (depends on power), separate control and isolation between channels
 - Supports master-slave parallel connection between 2 modules to extend power*1
 - Graphical operation interface with guided menus, significantly enhancing ease of use
 - Supports LIST programming, sequence editing, battery testing/emulating, user-defined waveform and correction scanning, etc
 - Built-in EIS (Electrochemical Impedance Spectroscopy) capability (IT2705 with IT27814 SMU module)
 - Integrated Ah/Wh statistics, automatically recording regenerative energy
 - Flexible display modes: Meter / Scope / Data Logger
 - Minimum data logging interval of 20 μ s
 - Web control supported, allowing full functionality through a standard browser
 - Standard interfaces: USB / LAN / CAN / Digital I/O, with free control software PV2700 included
- *1 IT27814/IT27814E can be parallel connection only under CC mode.

Models and Options

The IT2705 main frame can be equipped with up to eight 200W modules or four 500W modules, which can be bidirectional power supply modules, DC power

supplies modules, or regenerative load modules and SMU. The detailed model list is shown in the table below.

Voltage	Current	Power	DC power supply	Bidirectional power supply	Regenerative load	SMU
20V	3A	20W	-	-	-	IT27814
	3A	20W	-	-	-	IT27814E
30V	15A	200W	IT27134	IT27334	IT27534	-
	30A	500W	IT27154	IT27354	IT27554	-
60V	10A	200W	IT27135	IT27335	IT27535	-
	20A	500W	IT27155	IT27355	IT27555	-
150V	5A	200W	IT27137	IT27337	IT27537	-
	10A	500W	IT27157	IT27357	IT27557	-

1.2 Front Panel Overview

The front panel of the IT2705 series instrument is shown below.

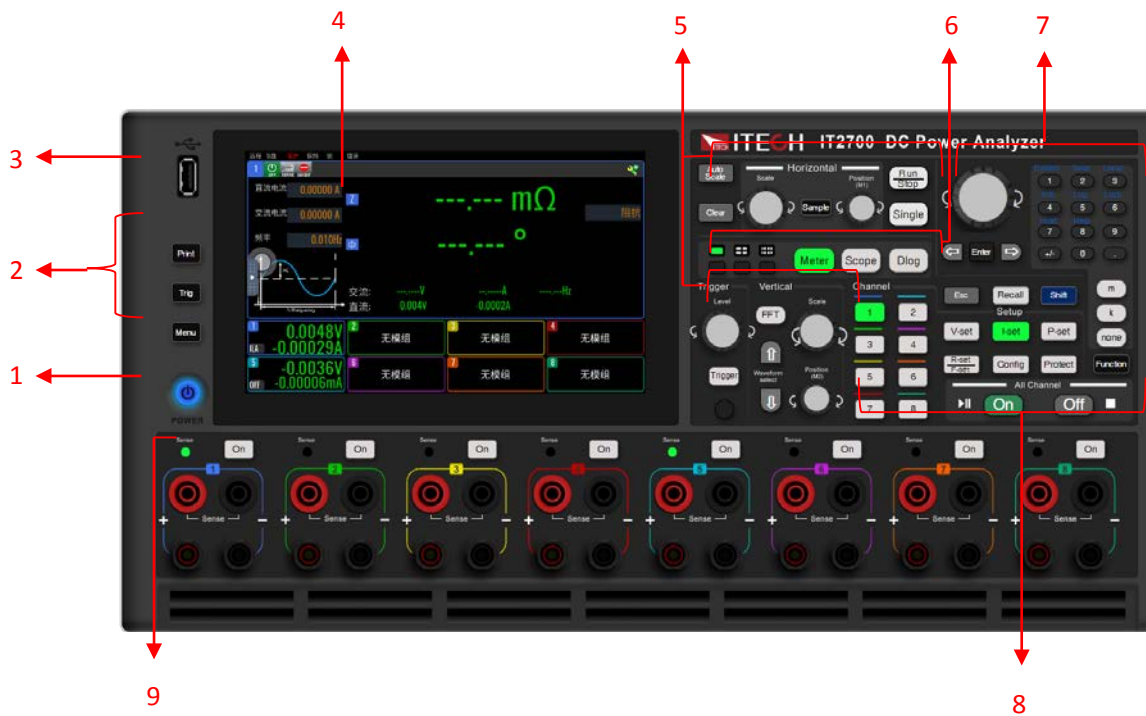

No.	Name	Description
1	Power Switch	Turns the instrument power on or power off. This key is reserved and temporarily unavailable.
2	Print	Use the Print key to take a picture of the interface.
	Trig	Use the Trig key to provide a panel trigger signal.
	Menu	Use the Menu key to access the menu page to display all function modules.

3	Memory port	USB Memory device connector
4	Display	Displays all instrument functions - information changes based on selected function.
5	Waveform Display controls	Controls the scope and data logging views.
6	Measure keys	Selects the measurement function - Meter View, Scope View, or Data Logger.
7	Numeric/direction keys	Used to set parameters and move menu, cursor, and other directional buttons.
8	Function keys	This area of the keypad is used to set the corresponding parameters and selection functions for each channel.
9	On keys	The output switch key of channel

1.3 Keyboard Introduction

1.3.1 Function Keys

The keys for Channel Setup part is used to set the corresponding parameters of the channel, including switching the channel number, setting the voltage, current, power and other parameters. The detailed description of the keys is as follows:

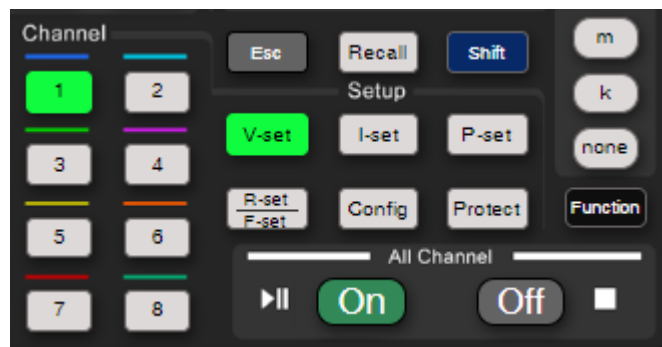

Name	Description
1~8	Switch channel button, channel not online is grayed out.
Esc	Exit Key. Press this key to cancel or exit the present operation.
Recall	Callback key to recall a stored system parameter setting.
Shift	Composite key, combined with other keys to realize functions marked above keys.
V-set	Voltage setting key to set the output voltage value of the instrument.
I-set	Current setting key to set the output current value of the instrument
P-set	Power setting key to set the output power value of the instrument

R-set	Resistance setting key or frequency setting key with different functions for different function.
F-set	
Config	Enter the config menu interface
Protect	Enter the Protect menu interface
On/Off	Turn on or off the outputs of all channels
m/k/none	m: Unit mill, used when setting units for mA or mV. k: Unit Thousand. When using kW, set the unit. None: Default unit.
Function	Access to the Advanced Functions menu interface

1.3.2 Push-on Knob

The IT2705 series Power system provides several knobs on the front panel as shown in the next figure.



The functions of the push-on knob is described as follows.

- Adjust the Value Setting
In the value setting interface, rotate the knob clockwise to increase the set value and anticlockwise to decrease the set value.
- Select Menu Item
The knob can also be used to view menu items. In the menu item display interface, turning the knob clockwise indicates that the next menu item is selected, and turning the knob anticlockwise indicates that the previous menu item is selected.
- Confirm settings
After completing the value setting or selecting a menu item, pushing the knob acts like pressing **[Enter]** key to confirm the operation.

Left and right arrow keys: Used to adjust the cursor to a specified position or to page left and right to display setting items.

Enter: confirm setting

1.3.3 Composite key

Composite key **[Shift]**, combined with other keys to realize functions marked above keys. In this manual, composite key is displayed as **[Shift]+[Esc]**. Firstly, press **[shift]** and the shift key will be lighted, and then press the function key, the detailed functions are listed as follows.



Name	Description
[0]-[9]	Number key. Enter the number directly
+/-	Positive and negative signs
.	Decimal point
[Shift]+[1](System)	Enter the System setting menu. Used to set the system parameters.
[Shift]+ [2] (Save)	Save the common parameter settings.
[Shift]+[3] (Local)	Switch remote control mode to local control mode.
[Shift]+[4] (Info)	View instrument information
[Shift]+ [5] (Log)	Enter the system log interface.
[Shift]+ [6] (Lock)	Turn the keyboard lock on or off.
[Shift]+ [7] (hold)	Pressing this key holds the currently measured parameter.
[Shift]+ [8] (Help)	Get help information.

1.3.4 Oscilloscope Adjustment Keys





Name	Description
Auto Scale	When using the oscilloscope function, press Auto Scale to set the display scale automatically.
Clear	Clears the sampling data.
Scale	Turn this knob to adjust the horizontal scale or vertical scale. Pressing this button has no other

	function.
Position	<p>Rotating the knob corresponding to Horizontal adjusts the horizontal reference. In the initial state, the reference is centered.</p> <p>Rotate the knob corresponding to Vertical to adjust the vertical position of the waveform.</p> <p>Press the Position button to zero out the position.</p>
Sample	Press this button to set the sampling mode.
Run/Stop	Start or stop data sampling.
Single	Sampling once
Level	Turn this knob to adjust the trigger level. Press this button to zero the trigger level.
Trigger	Press this knob to set trigger-related options.
Force	This button enforces an immediate trigger event.
FFT	Reserved
Waveform Select	To switch the waveform of each channel of the oscilloscope, switch the buttons of each channel below the oscilloscope interface.

1.3.5 Setting Display Layout

The IT2705 series instruments support up to 8 channels of simultaneous output, each output has its own measurement capability. When the Meter view is displayed, the measurement system continuously measures the output voltage and current.



Name	Description
	The selected channel is enlarged and displayed in the main window. A small window of 8 channels (for 8 channels) or 4 channels (for 4 channels) is displayed below.
	<p>The screen display is 4+4 for 8 channels, with four large window displays and other four channels in small windows.</p> <p>Display 4 large window for 4 channels.</p>
	The screen is divided into 8 small window displays.
Meter	Press this button to switch to the Meter measurement interface.
Scope	Press this button to switch to the scope interface.
Dlog	Press this button to switch to the data recorder interface.

1.4 Rear Panel Overview

The rear panel of the IT2705 series is shown below.

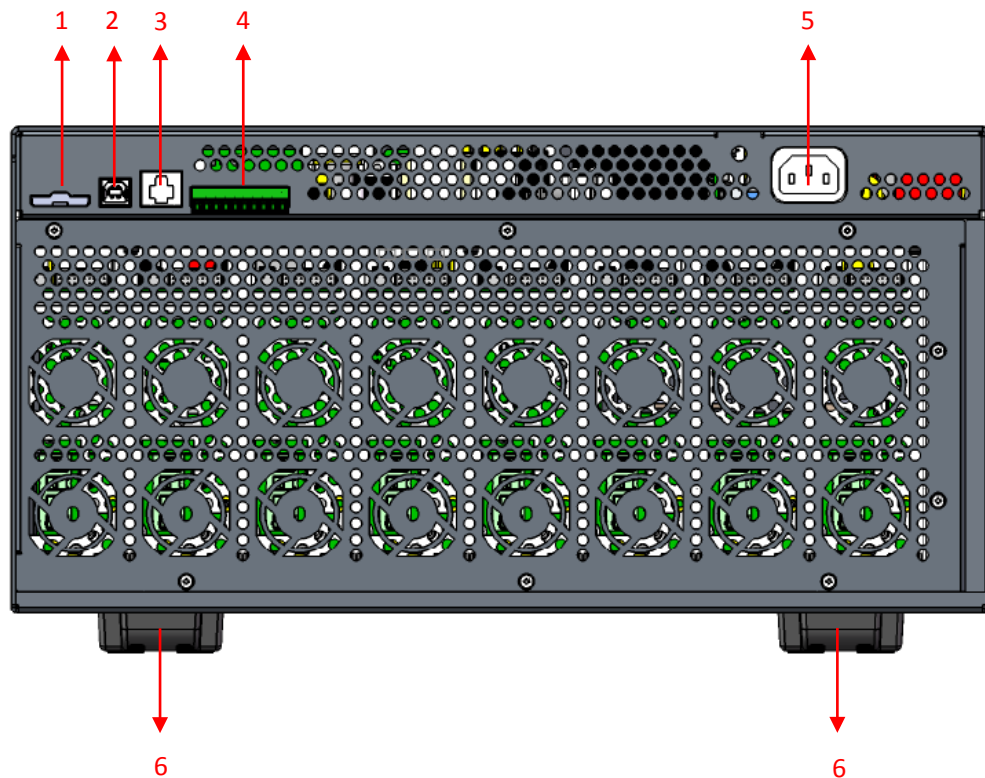

No.	Name	Description
1	BATTERY	Install the battery.
2	USB interface	USB communication interface.
3	LAN interface	LAN communication interface
4	I/O terminals/CAN interface	<ul style="list-style-type: none"> ● Digital Port ● CAN communication interface CAN-H and CAN-L
5	AC Input	The AC power cord is connected to this outlet and supports 100~240VAC input.
6	Foot	Instrument feet

1.5 View Instrument Identification

You can quickly view the output ratings, model numbers and options of all power modules installed in your instrument. You can also view the mainframe serial number and firmware revisions. Press the Menu key and then press the Info key. The instrument information window will appear.

Chapter2 Inspection and Installation

2.1 Unpacking and Transportation

Unpacking

For cabinet products, they are packaged in wooden boxes at the factory. After you receive them, please refer to the unpacking instructions provided with the box for disassembly; for products packaged in cartons, please use appropriate tools for unpacking.

It is recommended to keep the complete transport packaging for the lifetime of the device for relocation or return to the manufacture for repair.

Transportation

If you need to transport non-cabinet products, you must pay attention to the following to ensure the safety of equipment and personnel.

CAUTION

- **Before moving, make sure that the cabinet or stand where the equipment will be placed has been fixed and meets the load-bearing conditions to avoid tilting and collapsing, causing personnel to be injured, and equipment broken.**
- **Due to the weight of the product, transport by hand should be avoided where possible. If unavoidable, carry it with two people and holding the product shell and not external parts (such as handles, electrodes, knobs, etc.).**
- **When carrying, be prepared to bear the weight to avoid sprains or being crushed by heavy objects.**
- **Use suitable safety clothing, especially safety shoes, when carrying the equipment, as due to its weight a fall can have serious consequences.**

After unpacking the cabinet product, if you need to move it to other places, you must pay attention to the following matters to ensure the safety of equipment and personnel.

CAUTION

- **The cabinet product is very heavy. Before moving to another location, confirm whether the ground load is in compliance.**
- **During the process of moving the cabinet, it is recommended that two or more people cooperate and push it slowly and at a constant speed. If you encounter a pit, you need to pay special attention. It is forbidden to push it quickly, otherwise it will easily cause excessive inertia and cause the casters at the bottom of the cabinet to jam and the cabinet to fall.**
- **It is not advisable to push down the slope to prevent the cabinet from falling down due to the shift of the center of gravity. It is recommended to use a forklift or crane to move the cabinet.**

- ITECH 27U and 37U cabinets are equipped with hoisting rings as standard on the top. It is recommended to use a crane equipped with a four-leg hoisting belt structure for horizontal hoisting and moving, and ensure that the four hoisting belts are the same length to avoid cabinet skew during movement. As shown below.
- After moving to the destination, please lock the four casters to secure the cabinet.
- The cabinet should be placed on a level ground. It is forbidden to place the cabinet on a sloped ground.

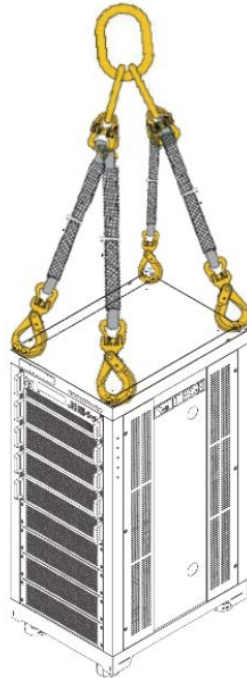

2.2 Verifying the Shipment

Open the package and check the articles within package box before operation. In case of any non-conformity, missing or appearance wearing, please contact ITECH immediately.

The package box should comprise:

Device name	Quantity	Model	Remarks
Multi-channel modular power system	x1	IT2705 series	For the specific models included in this series, refer to 1.1 Brief Introduction.
Power Cord	X1	-	Number of the power cords vary depending on the model, See the Section 2.5 Connecting the Power Cord for power cord connection.
USB cable	x1	-	Used for communicating with the PC.
LAN cable	x1	-	Used for communicating with the PC.
Pull-out module tool	x1	-	When removing the module, assist in extracting the module.
Calibration Certificate	x1	-	Test report before delivery.



NOTE

After confirming that package contents are consistent and correct, please appropriately keep package box and related contents. The package requirements should be met when the instrument is returned to factory for repair.

2.3 Instrument Size Introduction

The instrument should be installed at well-ventilated and rational-sized space. Please select appropriate space for installation based on the power supply size. Do not block the air intake and exhaust of units.

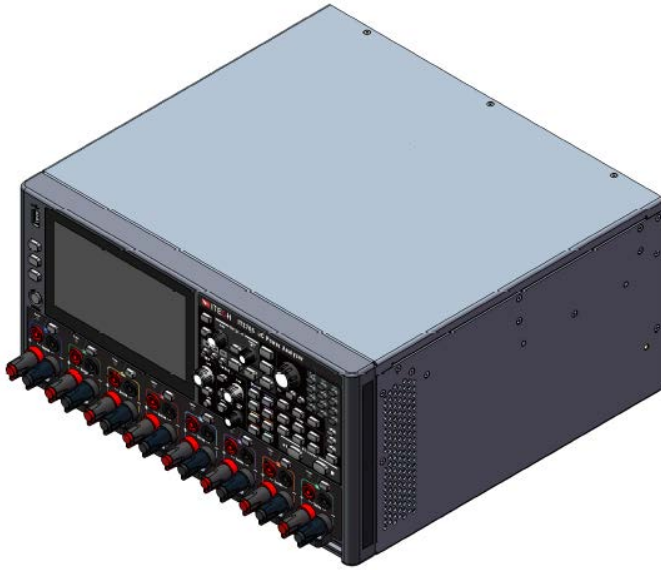
IT2705



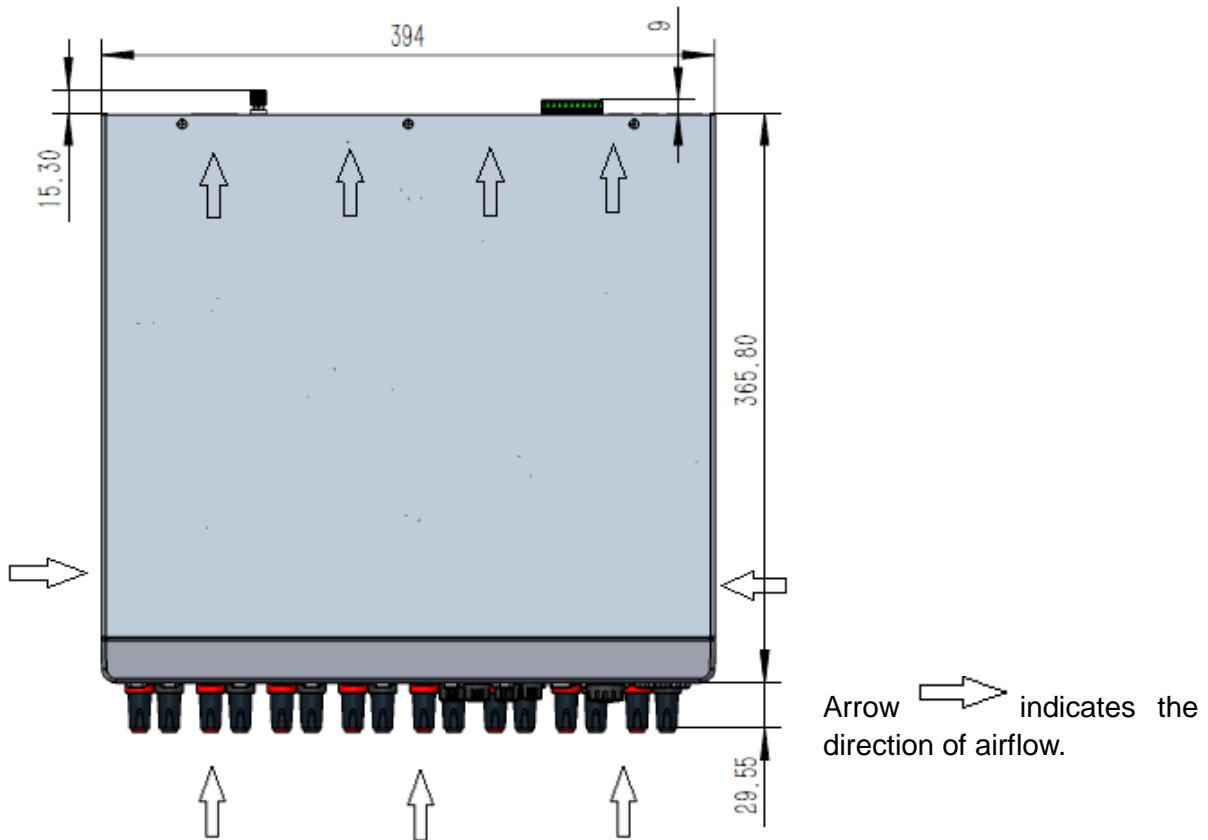

2.4 Installing the Instrument

2.4.1 Power Module Installation

CAUTION

The information in this section applies if you have purchased an IT2700 mainframe without the power modules installed, or if you are adding a power module to the mainframe.

Turn the mainframe off and disconnect the power cord before installing or removing power modules. Observe all standard electrostatic discharge precautions before handling electronic components.

Preparation before installation

The screws used for removing the top cover and mounting the module are M3 type screws, so please prepare the corresponding Phillips screwdriver in advance.

Installation Step

1. Remove the rear cover.

Loosen the screws in the locations shown below and remove the rear cover gently. Please save the screws, you will need to use them again when installing the back plate.

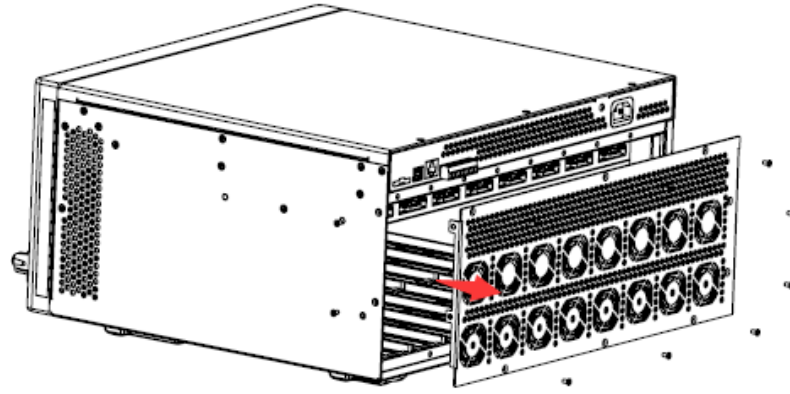

2. Insert the module into the module installation area, as shown in the figure below.

After removing the rear panel of the machine, the channel numbers are arranged from right to left as CH1 through CH8.

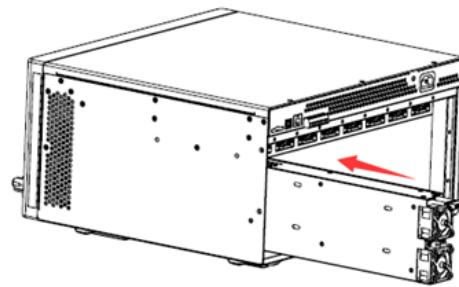

IT27814/500W Module

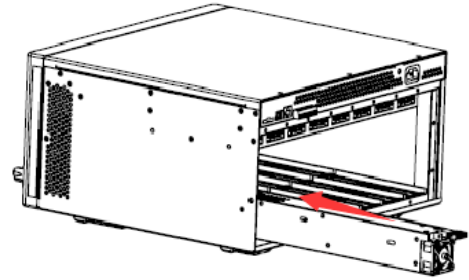

200W Module

3. Connecting the cable.

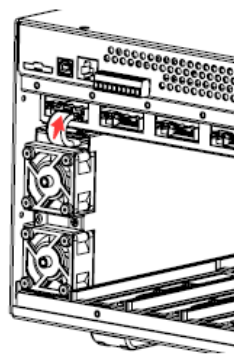

IT27814 Module

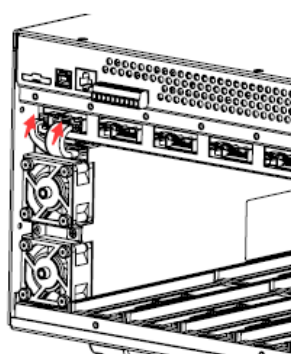

500W Module

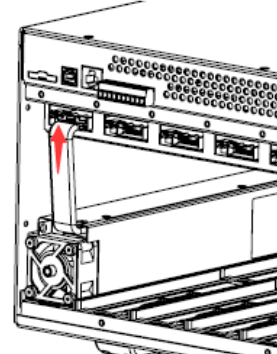

200W Module

4. After the module is installed, install the instrument backplate as shown in the figure below.

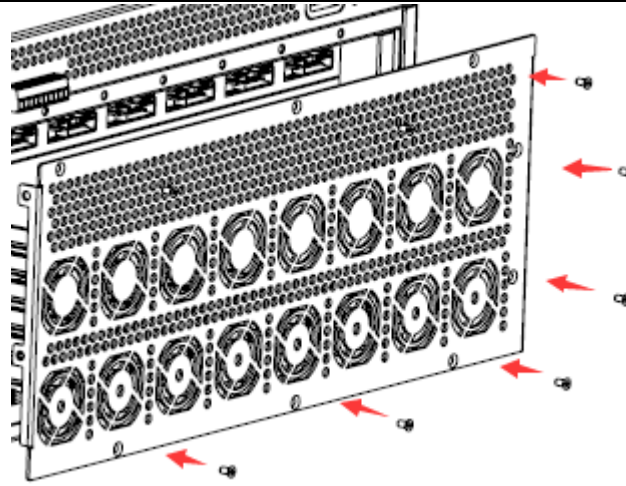

5. After installing the instrument backplate, secure the modules with the screws provided in the box. Taking 8 modules as an example, see the figure below.

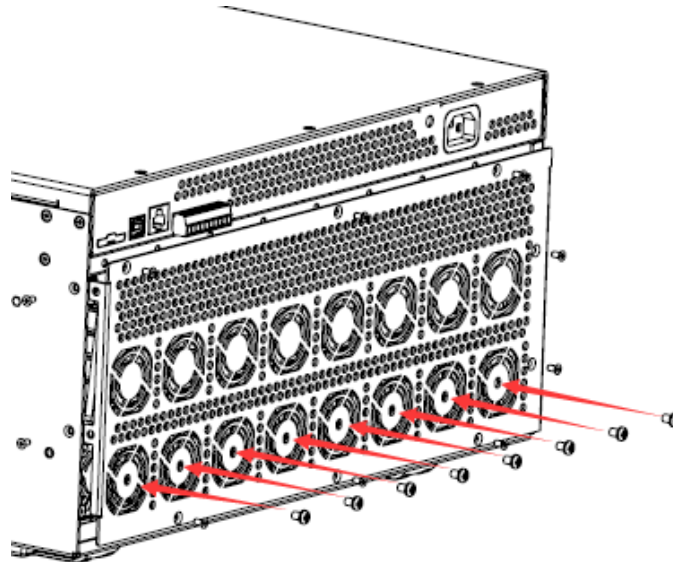

2.4.2 Disassembly module

1. Remove the rear cover.

Loosen the screws in the locations shown below and remove the rear cover gently. Please save the screws, you will need to use them again when installing the back plate.

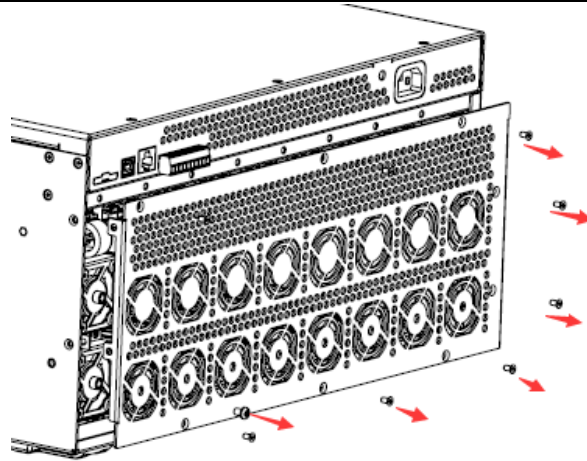

1. Unplug the connected cable, using the 500W module as an example.

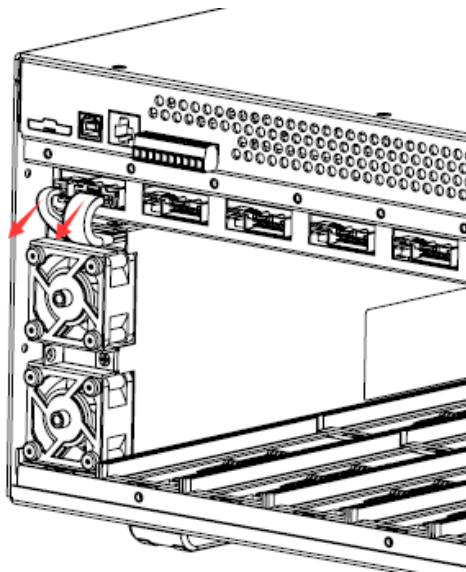

2. The box comes with a tool used to pull-out module. Insert the tool into the module as shown below, then pull out the module.

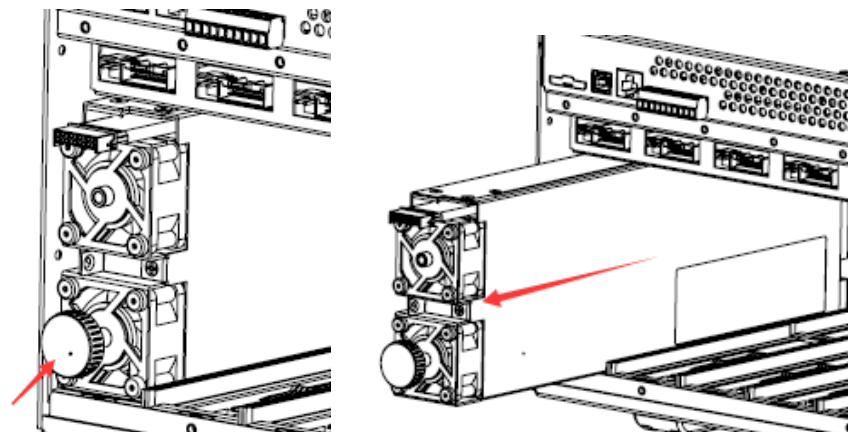

2.4.3 Install the battery

The IT2705 series instruments support functions such as system time setting and display. These functions require external battery power. The instruments are shipped without batteries by default. If users need to use these functions, they

must purchase and install batteries themselves.

rated voltage: 3V

OCV: 3.05~3.45V

Size: 19.7~20.0mm×3.0~3.2mm

Recommended model: CR2032

1. Press the battery compartment, and then pull out the battery compartment after it pops out.

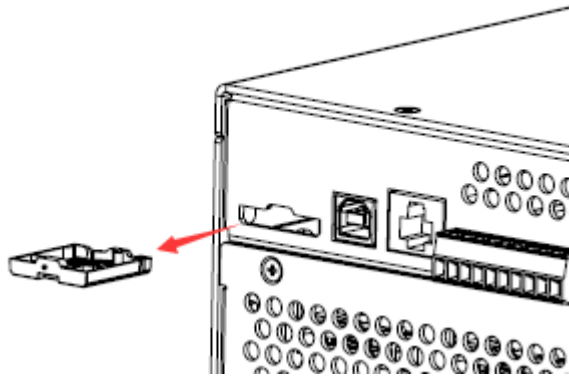

2. Install the battery.

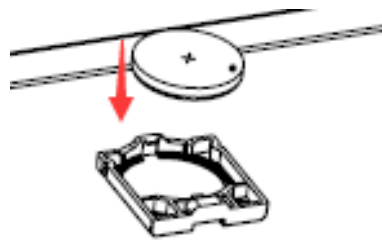

3. Reinstall the battery compartment into the rear panel of the instrument.



2.5 Connecting the Power Cord

Connect power cord of standard accessories and ensure that the power supply is under normal power supply.

Before connecting the power cord

To prevent electric shock and damage to the instrument, observe the following precautions.

WARNING

- Before connecting power cord, be sure to confirm that the power voltage matches with the rated input voltage of the instrument.
- Before connecting power cord, be sure to switch off the instrument. Verify that there is no dangerous voltage on the connection terminals.
- To avoid fire or electric shock, Make sure to use the power cord supplied by ITECH.
- Be sure to connect the power cord to the AC distribution box with protective grounding. Do not use terminal board without protective grounding.
- Do not use an extended power cord without protective grounding, otherwise the protection function will fail.
- Ensure that the power cord connection terminals are either insulated or covered by the supplied protective cover so that no accidental contact with lethal voltage can occur.

CAUTION

Safety agency requirements dictate that there must be a way to physically disconnect the AC mains cable from the unit. A disconnect device, either a switch or circuit breaker must be provided in the final installation. The disconnect device must be close to the equipment, be easily accessible, and be marked as the disconnect device for this equipment.

Categories of Power Cords

The standard power cord types are as follows. Please select appropriate power cords appropriate to local voltage based on the specifications of power cords below. If purchased model fails to meet local voltage requirements, please contact distributor or factory for change.

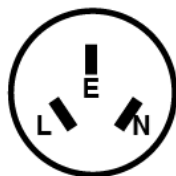

China
IT-E171



United States &
Canada & Japan
IT-E172

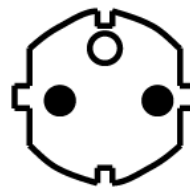

Europe
IT-E173



England
IT-E174

AC Power Input Level

This series power supply comes default with 100Vac-240Vac, 47Hz~63Hz single input range.

2.6 Connecting Test Lines (Optional)

Test lines are not standard accessories of the instrument. Please select optional red and black test lines for individual sales based on the maximum current value. For specifications of test lines and maximum current values, refer to **“Specifications of Red and Black Test Lines”** in **“Appendix”**.

WARNING

- Before connecting test lines, be sure to switch off the instrument. Power switch is in Off position. Otherwise, contact with output terminals in rear panel may cause electrical shock.
- To avoid electrical shock, before testing, please make sure the rating values of the testing lines, and do not measure the current that higher than the rating value. All test lines shall be capable of withstanding the maximum short circuit output current of the power supply without causing overheat.
- Do not short the battery when connecting or disconnecting the battery testing circuit. Short circuit may cause severe accident.
- It is recommended that for battery testing, a fuse must be connected in series between the power supply and the battery to prevent short circuits caused by any problems.
- Be careful not to reverse the battery/capacitor connection, reverse connection will cause damage to the instrument, even if it is not powered on.
- If several loads are provided, each pair of load wires shall safely withstand the rated short circuit output current of the power supply under full load.
- Always use test lines provided by ITECH to connect the equipment. If test lines from other factories are used, please check that the test line can withstand maximum current.

Test Cables

ITECH provides alone-sold test lines for professional measure. Test lines in sold and related introduction are shown below. All lengths in the figure are in mm.

- IT-E6061 Crown Round Tip lead

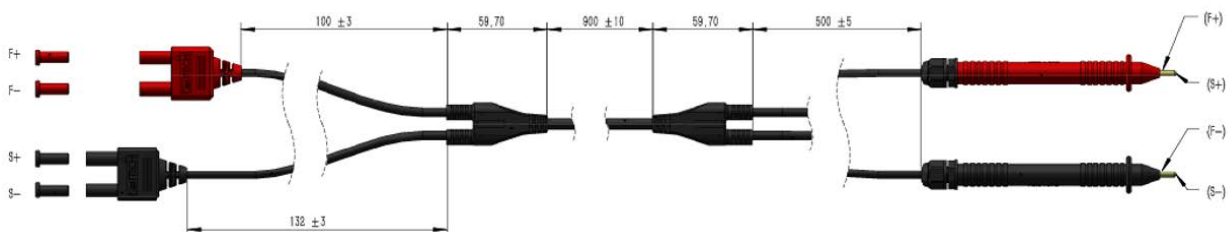

Either for plane contacts or relay terminals that are not easy to clamp or small objects like connectors, you just need to touch the test lines against the DUT for four-terminal measurement. The meter pen can be directly unscrewed for changing For detailed length specification, see the figure above.

- IT-E6062 alligator clip type lead

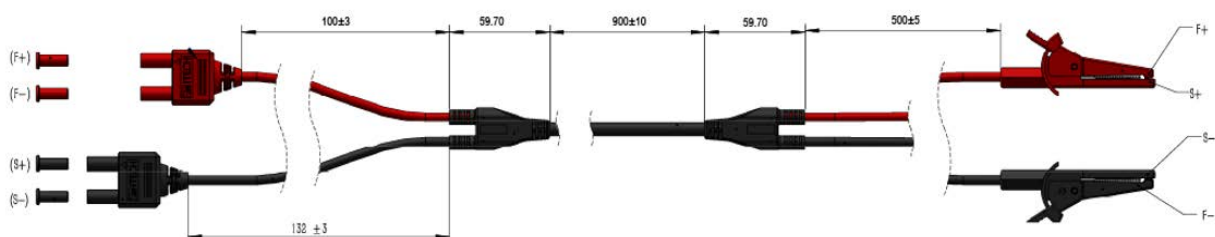

It can be used to clamp thick cylinder parts of DUT and is easy for operation. To take four-terminal measurement, directly clamp the DUT terminals. For detailed length specification, see the figure above.

- IT-E6063 Cone Tip type lead

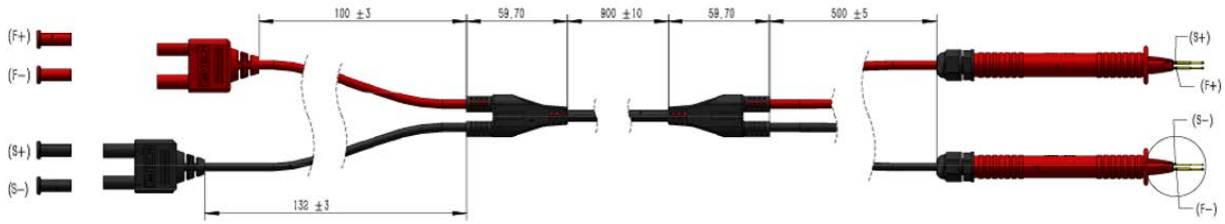

The test lines are needle-type test lines with high dielectric strength designed, especially for high-voltage battery packs or batteries with high docking ground potential. Two parallel pins are designed at top for measurement through stable touch. The meter pins are changeable. For detailed length specifications, see the figure above.

- IT-E6064 universal pin and alligator clip lead

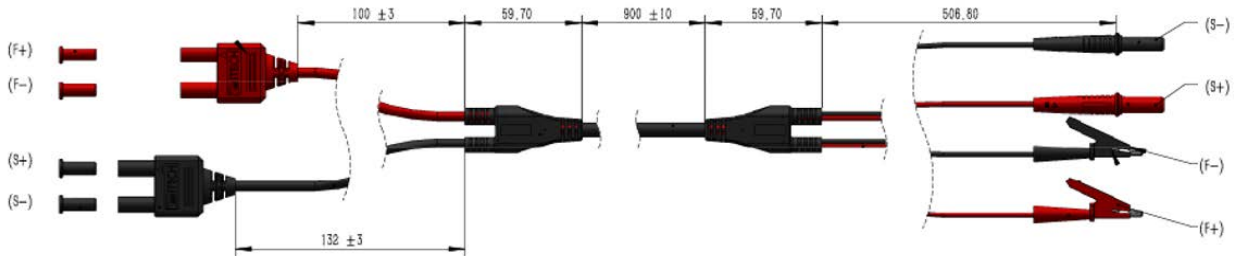

The universal pin and alligator clip lead can connect and test DUT intuitively and conveniently.

Connecting the DUT (Local Measurement)

The instrument supports two kinds of wiring methods with the DUT: local measurement and remote measurement (SENSE). The default test mode is local measurement.

Please confirm that the Remote Sense function in the menu is set to Off, otherwise the instrument will report an error in the present connection mode.

The connection diagram for CH1 and CH2 is shown as follow:

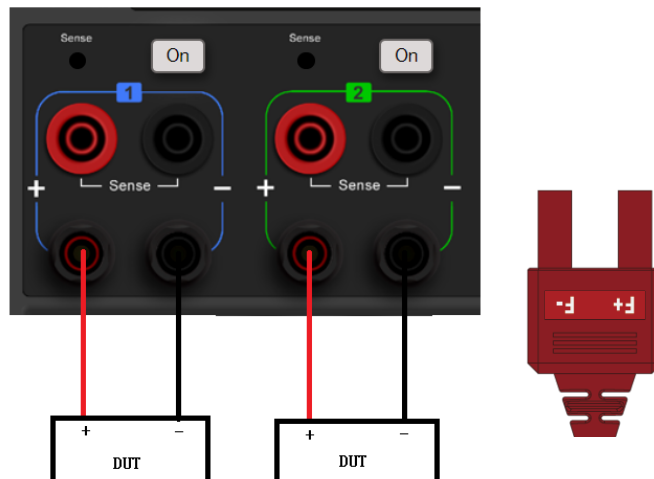

1. Confirm that the power switch is in the OFF position and verify that there is

no dangerous voltage on the connection terminals.

2. Insert the test lead directly or Unscrew the knob on the output terminal to connect the test lead or.

When maximum current that one test cable can withstand fails to meet the rated current, use multiple pieces of red and black test cables.

3. Connect the other end of the red and black cables to the DUT. The positive and negative poles must be properly connected and fastened when wiring.

Connecting the DUT (Remote Sensing)

When the DUT consumes large current or the wires are too long, there is a voltage drop on the wires between DUT and output terminals of the power system. To maximize measurement accuracy, the power system provides the remote measurement terminals S+ and S- on the rear panel, which can be used to measure the terminal voltage of the DUT.

The connection diagram and steps of remote measurement are as follows:

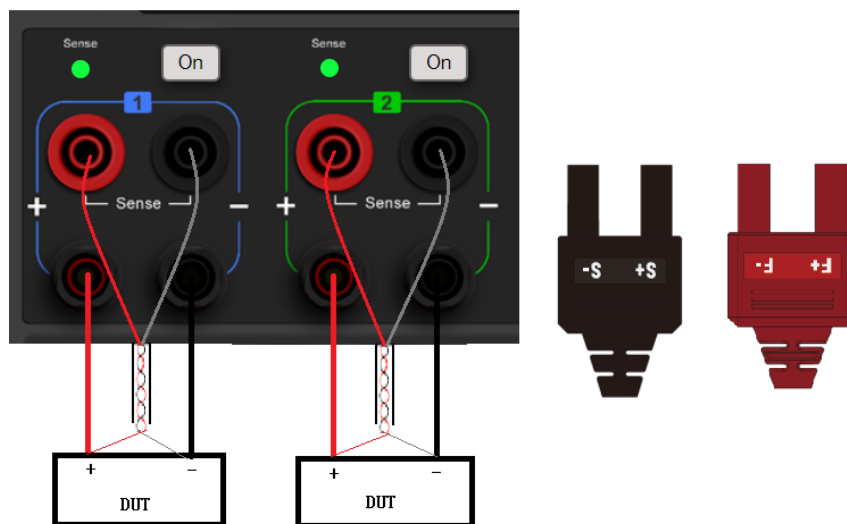

1. Confirm that the power switch is in the OFF position and verify that there is no dangerous voltage on the connection terminals.
2. Refer to the wiring diagram and connect the Vs+ and Vs- with armored twisted-pair cables. Insert the test lead directly or Unscrew the knob on the output terminal to connect the test lead.
3. Connect the other end of the remote sense cables to the DUT.
4. Connect the other end of the red and black cables to the DUT. The positive and negative poles must be properly connected and fastened when wiring.
5. Power on the instrument and turn on the Sense function of the instrument.

2.7 Remote Control

This series power system comes standard with three communication interfaces: USB, LAN and CAN, you can choose one of them to communicate with your computer.

2.7.1 USB Interface

Use cables with both USB ends to connect with IT2705 and PC. All functions are programmable over the USB.

The USB488 interface capabilities are described below:

- The interface is 488.2 USB488 interface.
- The interface accepts REN_CONTROL, GO_TO_LOCAL, and LOCAL_LOCKOUT requests.
- The interface accepts MsgID = TRIGGER USBTMC command message and forwards TRIGGER requests to the function layer.

The USB488 device functions are described below:

- The device understands all mandatory SCPI commands.
- The device is SR1 capable.
- The device is RL1 capable.
- The device is DT1 capable.

2.7.2 LAN Interface

When the user connect PC through LAN interface, the following is required to use the LAN interface. The LAN interface complies with the LXI standard.

Under the web control mode, the instrument and computer must communicate through the LAN interface. The default IP address is **192.168.200.100** for the first time, users can use the default IP address.

Connect Interface

Connect the LAN interface of power supply to the computer with a reticle. The gateway address should be consistent with that of the PC, and the IP address should be at the same network segment with the PC's IP address.

For the first time, it is recommended that you first use USB communication to modify the IP address of the instrument by sending commands. You can also directly modify the IP address of your computer and the same network segment of the instrument.

Using Web Server

The instrument has a built-in Web server for monitoring and controlling the instrument through a Web browser in PC.

To use the Web server, connect the instrument and PC over LAN interface and enter the instrument's IP address into the address bar at the top of your PC's Web browser, you can access the front panel control functions including the LAN configuration parameters.

1. The format of the address entered in the address bar of the browser is **http://192.168.200.100**. The specific IP address is subject to the actual instrument settings. The initial IP address is 192.168.200.100. If the IP address has been changed before, you can reset it by pressing the **LAN-Reset** button on the rear panel.

The opened page is displayed as follows:

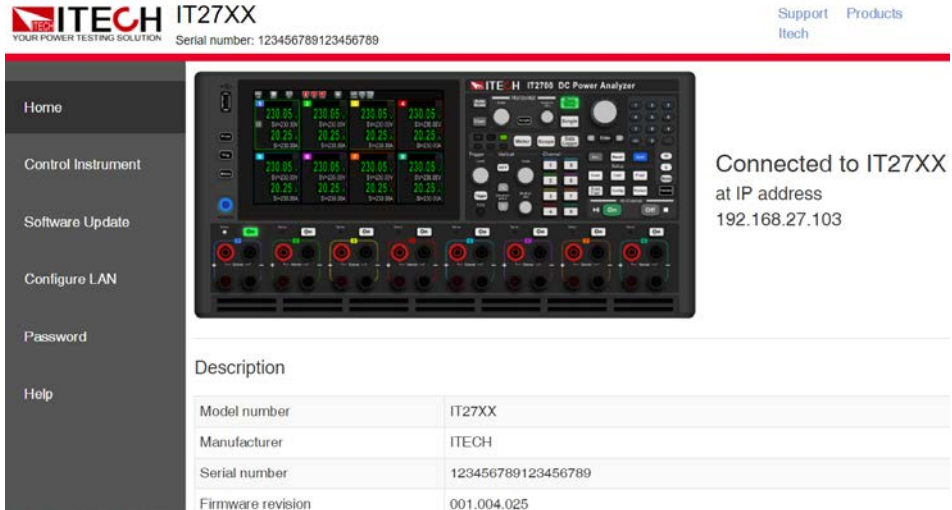

You can select different pages by clicking the buttons shown in the navigation bar on the left side of the window. The detailed descriptions are as follows.

- Home: Web home interface, displays the model and appearance of the instrument;
- Control Instrument: Enables the Web control to begin controlling the instrument. This page allows you to monitor and control the instrument.
- Software Update: Performs a system upgrade.
Click the Software Update file selection area, select the system upgrade installation package (e.g., IT2700-U-V000.002.072all), and click Update to perform the upgrade. After the upgrade is complete, restart the instrument.
- Configure LAN: Reconfigure the LAN parameters;
- Password: Change the network control login password.
- Help: Display the help screen.

2.7.3 CAN Interface

The CAN interface is located on the rear panel of the instrument and is connected to the computer using a CAN communication cable.

Definition of CAN Pins

The definition of CAN pins are as follows.

Pins	Description
H	CAN_H
L	CAN_L

CAN Troubleshooting

If you meet some problems when communicating with PC by CAN interface, please check the following items:

- PC and the instrument must have the same baud rate.
- Ensure you have used the correct communication cable (CAN_H, CAN_L). Please pay attention that some cable may not have a correct internal wiring even it is with an appropriate plug.

- The interface cable is correctly connected (CAN_H to CAN_H, CAN_L to CAN_L).
- If the communication signal is poor or unstable, it is recommended to connect a 120 Ω terminating resistance.
 - The connection diagram of a single device is as below.

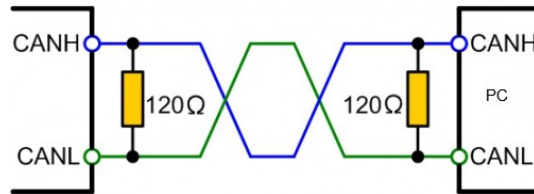

- The connection diagram of multiple devices is as below.

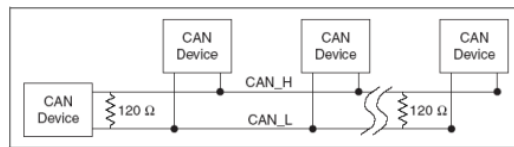

Chapter3 Getting Start

3.1 Power-on the Instrument

A successful selftest indicates that the purchased power product meets delivery standards and is available for normal usage.

Before operation, please confirm that you have fully understood the safety instructions.

Precautions

To prevent electric shock and damage to the instrument, please observe the following precautions.

WARNING

- Before connecting power cord, be sure to confirm that the power voltage matches with the supply voltage.
- Before connecting power cord, be sure to switch off the instrument. Verify that there is no dangerous voltage on the terminals before touching them.
- To avoid fire or electric shock, make sure to use the power cord supplied by ITECH.
- Be sure to connect the main power socket to the power outlet with protective grounding. Do not use terminal board without protective grounding.
- Do not use an extended power cord without protective grounding, otherwise the protection function will fail.
- Ensure that the input electrodes are either insulated or covered using the safety covers provided, so that no accidental contact with lethal voltages can occur.
- If you notice strange sounds, unusual odors, fire, or smoke around or from inside the instrument, flip the POWER switch to the (O) side to turn the instrument off, or remove the power cord plug from the outlet. The detachable power cord may be used as an emergency disconnecting device. Removing the power cord will disconnect AC input power to the unit.

CAUTION

Safety agency requirements dictate that there must be a way to physically disconnect the AC mains cable from the unit. A disconnect device, either a switch or circuit breaker must be provided in the final installation. The disconnect device must be close to the equipment, be easily accessible, and be marked as the disconnect device for this equipment.

Power Switch Introduction

User can press the power switch of IT2700 series instrument directly to turn on or turn off the instrument.

The status of Power switch is as follows.



Turning the POWER Switch On

Check that the power cord is connected properly.

Flip the POWER switch to the () side to turn the instrument on. The front panel

display will light up after a few seconds. The indicator corresponding to the channel will blink.

Turning the POWER Switch Off

Flip the POWER switch to the () side to turn the instrument off.

After you turn the POWER switch off, wait at least 10 seconds after the fan stops before you turn the POWER switch back on.

3.2 Meter View

3.2.1 View Introduction

Press the **Meter** button in the instrument panel to enter the Meter View. Under Meter View, users can click the corresponding screen display button to select Single Channel View and Multi-Channel View.

single-output View

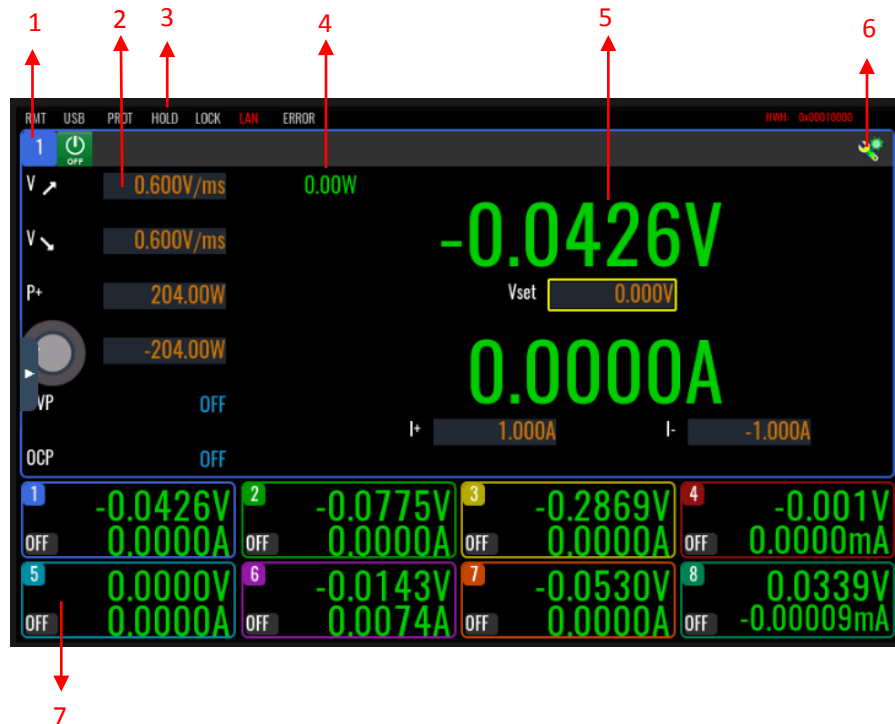

No.	Description
1	channel number and output status
2	Slope value, power limit value, protection function
3	Status bar
4	Power value and other measurements
5	Outputs set values and readback values, which can be set by clicking on the corresponding area or click V-set.
6	Configuration icon, click to quickly enter the general configuration interface of the current channel
7	Reduced window for multiple channels, clicking on the small window switches the present channel to large display.

Multichannel-output View



No.	Description
1	channel number and output status
2	Voltage and current measurements
3	Configuration icon, click to quickly enter the general configuration interface
4	Power measurement
5	Voltage /current setting value





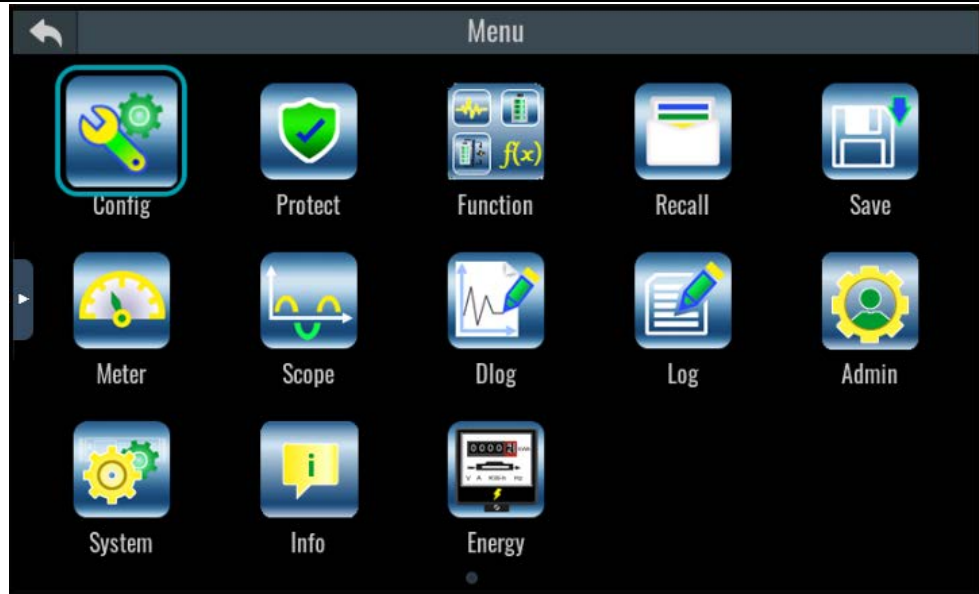



















3.2.2 Menu Interface











Press the [Menu] key to enter the menu setting interface. This interface contains all the function option icons, which can be selected by using the arrow keys or knobs, or you can directly touch and click the icons to enter the corresponding function setting page.



3.2.3 Introduction to Interface Symbols

The interface of IT2700 power supply will display the following symbols. All the symbols and description are listed in the table below.

Symbol	Function description	Symbol	Function description
	Enter config menu		Output is off
	Output delay		CR mode
	CV mode		CP mode
	CC mode		Battery mode
	Battery charge mode		Battery discharge mode
	Battery simulation mode		EIS mode
	Remote Sense		Zero Calibration of Impedance
	Short circuit		Load Undervoltage alarm
	LIST running		LIST idle state
	LIST is waiting for trigger signal		LIST is ending
	Inhibit-living		Inhibit-latch
	Under current protection		Under voltage alarm

Symbol	Function description	Symbol	Function description
	Loop Oscillation Protection		Over current protection
	Positive and negative are reversed		Sense protection
	OVP		OTP
	Under Voltage protection		OPP
	Foldback protection		Asymmetric Current Protection

3.3 Select the Channel

This series of instruments support multiple channels, and different channels can be inserted into different modules. Setting parameters and other operations can only be done for the active channel, if you need to operate other channels, you can directly press the channel key in the panel or click the corresponding channel's display window in the screen.

3.4 Set Parameters

In CV mode, when you press the [**V-set**] key, voltage setting operation can be performed. In the voltage setting area, use the numeric keys or the adjustment knob to input the voltage value, and press [**Enter**] to make this value effective.

The voltage setting ranges from 0V to the maximum output voltage value.

In CC mode, when you press the [**I-set**] key, the current setting operation can be performed. In the current setting area, use the numeric keys or the adjustment knob to input the current value, and press [**Enter**] to make this value effective.

Different modes use different setting buttons, please refer to the button introduction for detailed button functions.

Power output parameters or load carry parameters can be set directly in the Meter interface or in the Config menu.



3.5 Using the Front Panel Menu

The front panel of this instrument provides several menu buttons, users can use the front panel buttons to access the instrument menu, including Config menu, System menu, Protect menu and advanced function menu. You can also set the system related settings in the menus. Each menu is described as follows:

- **Config:** The menu allows you to set parameters related to the electrical performance of the instrument, including the operating mode, slope, output delay time, and power supply internal resistance.
- **System:** The menu allows you to set the system-related function switches, including key sound, Sense switch, power-on status, trigger mode, communication mode, data logging mode, digital I/O function setting, parallel connection setting, viewing instrument-related information, restoring the factory value, and voltage quick-zero setting.

- **Protect:** The menu allows you to set instrument protection-related parameters, including OCP/OVP/OPP/UCP/UVP.
- **Function:** Functions such as Output Sequence, Custom Waveforms, or Battery Charge Test can be set in the Advanced Functions menu.

3.6 Config Menu

click the button  or press the button  to enter the configuration menu interface, in which you can set the electrical performance parameters, sampling-related settings and trigger settings.

3.6.1 Source Config Menu

Source	Priority	The instrument run mode	
		Voltage	Voltage priority mode
		Current	Current priority mode
	Voltage/Current Setting	Sets the voltage value/current value, which varies depending on the selected Priority.	
	Voltage/Current Slew Settings	Voltage Slew Settings /Current Slew Settings	
		MAX/V_Rise	Voltage rise slope setting, checking the checkbox before MAX means that the slope is set to maximum. (Displayed when Priority is selected as Voltage)
		MAX/V_Fall	Voltage fall slope setting, checking the checkbox before MAX means that the slope is set to maximum. (Displayed when Priority is selected as Voltage)
		MAX/I_Rise	Current rise slope setting, checking the checkbox before MAX means that the slope is set to maximum. (Displayed when Priority is selected as Current)
		MAX/I_Fall	Current fall slope setting, checking the checkbox before MAX means that the slope is set to maximum. (Displayed when Priority is selected as Current)
	Tracking Slew	Rising and Falling Slope Tracking, checked to synchronize the setting of the rising and falling slope values.	
	Current limit	When the Priority selection is Voltage, the current limit need to set.	
		+I limit	Positive current limit
		-I limit	Negative current limit
		Tracking limits	Limit Setting Tracking, checked to synchronize the setting of +I and -I.
	Voltage limit	When the Priority selection is Current, the voltage limit is set.	
		V High	Voltage upper limit
		V Low	Voltage lower limit

		Tracking limits	Limit Setting Tracking, checked to synchronize the setting of V High and V Low.
	Power limits	Power limit setting.	
		+P limit	Positive power limit
		-P limit	Negative power limit
		Tracking limits	Limit Setting Tracking, checked to synchronize the setting of +P limit and -P limit.
	Internal Resistance	When the Priority selection is Voltage, the Internal Resistance is set.	
	Sink Resistance	When the Priority selection is Current, the Sink Resistance is set.	
Measure	Measurement-related configurations.		
	Remote Sense	Remote: remote sense state. On: enable the remote sense Off: disable the remote sense	
	Measurement		
		NPLC	Number Power Line Cycles
		Aperture	Sampling frequency mode selection.
		Time Interval	Time sampling mode
		Line Frequency	AC power supply frequency
		Points	Sampling points
	Whour & Ahour	Measurement of watt-hour and amp-hour parameters.	
		Auto clear after output on Clear Whour,Ahour	
Output	Output configurations.		
	Power Relay Lock	Whether or not the output is isolated in the Off state.	
		On: Relay isolation when output is off Off: When the output is off, it is not isolated.	
	Output off Return to 0V	Used to control whether the voltage is quickly zeroed when the output is turned off.	
		On Off	
	Regulation Speed	Regulation speed	
		High1: High speed Low: Low speed	
Trigger	Trigger configurations		
	DC Setting	DC value setting Digital IO is PIN1~PIN7	
	Transient Trigger source	Transient system trigger Selectable trigger sources are Immediate Trigger, Bus, Manual Trigger and PIN1~PIN7 Digital IO Trigger.	
	Transient Trigger Out	When the transient selection outputs a trigger signal, the IO pin mapped to the class selection is pin 1 to pin 7.	
	Tout at the beginning of transient	When selecting a transient waveform, output a trigger signal externally at the start.	
	Tout at the end of transient	When the transient waveform ends, a trigger signal is output externally.	

3.6.2 Load Config Menu

Source	Const Mode	Setting the mode of instrument operation	
		CV	CV mode
		CC	CC mode
		CR	CR mode
		CP	CP mode
		CC+CV	CC+CV mode
		CC+CR	CC+CR mode
		CR+CV	CR+CV mode
		CP+CV	CP+CV mode
		CC+CP+CR+CV	CC+CP+CR+CV mode
		BSIM	Battery simulation mode
	Voltage/Current/Resistance/Power Setting	The settings of the load parameter in different modes vary depending on the Const Mode selected.	
	Voltage/Current/Resistance/Power Slew Settings	Slope setting	
		MAX V/R/P/I_Rise	Rising slope setting, checking the checkbox before MAX means that the slope is set to the maximum.
		MAX V/R/P/I_Fall	falling slope setting, checking the checkbox before MAX means that the slope is set to the maximum.
	Tracking Slew	Rising and Falling Slope Tracking, checked to synchronize the setting of the rising and falling slope values.	
Other limit			
	When Const Mode is selected as CV/ CC+CV/ CC+CR/CR+CV/CP+CV/ CC+CP+CR+CV /BSIM, the composite parameter limit value is set, and the parameter displayed in different modes is different.		
Under Voltage Inhibit	When Const Mode is selected as CC/CR/CP, set the on-load voltage limit.		
	Mode	Off: disable this function Living: Changes the load status in real time following the voltage change. When the voltage reaches the value of Voltage on, it starts to carry the load, and when the voltage reaches the value of Voltage off, it stops to carry the load. Latch: The load state does not follow the voltage	

			change and starts to load when the voltage reaches the Voltage on value.
	Enable Short	Check to enable the short circuit simulation state.	
Measure	Measurement-related configurations.		
	Remote Sense	Remote: remote sense state. On: enable the remote sense Off: disable the remote sense	
	Measurement		
		NPLC	Number Power Line Cycles
		Aperture	Sampling frequency mode selection.
		Time Interval	Time sampling mode
		Line Frequency	AC power supply frequency
		Points	Sampling points
		Whour & Ahour	Measurement of watt-hour and amp-hour parameters.
Output	Power Relay Lock	Whether or not the output is isolated in the Off state.	
		On: Relay isolation when output is off Off: When the output is off, it is not isolated.	
	Regulation Speed	Regulation speed	
		High1: High speed	
		Low: Low speed	
Trigger	Trigger configurations		
	DC Setting	DC value setting Digital IO is PIN1~PIN7	
	Transient Trigger source	Transient system trigger Selectable trigger sources are Immediate Trigger, Bus, Manual Trigger and PIN1~PIN7 Digital IO Trigger.	
	Transient Trigger Out	When the transient selection outputs a trigger signal, the IO pin mapped to the class selection is pin 1 to pin 7.	
	Tout at the beginning of transient	When selecting a transient waveform, output a trigger signal externally at the start.	
	Tout at the end of transient	When the transient waveform ends, a trigger signal is output externally.	

3.6.3 SMU Config Menu

Source	Emulation	Set instrument role	
		4Q Power Supply	4Q Power Supply
		2Q Power Supply	2Q Power Supply
		1Q Power Supply	1Q Power Supply
		CC Load	CC Load

		CV Load	CV Load
		CR Load	CR Load
		Voltage Measure	Voltage Measure
		Current Measure	Current Measure
		Battery Emulator	Battery Emulator
		Battery Charge	Battery Charge
		Esc	Exit this interface
	Operating in Priority	Operation mode	
		Voltage	CV mode priority
		Current	CC mode priority
	Voltage/Current Range	Select voltage or current range in different modes.	
	Voltage/Current/Resistance Setting	The display parameters vary depending on the selected operating mode.	
	AC	AC Parameter Settings for Impedance Measurement. Displayed when the simulation option is set to 4Q/2Q/1Q power supply and the Operating in Priority is selected as current. Check the box before AC when using.	
		Iac: AC current value	
		Frequency: AC frequency value	
	Voltage/Current Slew Settings	Bandwidth Ramp Setting	
		MAX V/I Rise	Voltage/Current rise slope setting, checking the checkbox in front of MAX means that the slope is set to maximum.
		MAX V/I Fall	Voltage/Current Fall slope setting, checking the checkbox in front of MAX means that the slope is set to maximum.
		Tracking Slew	Rising and Falling Slope Tracking, checked to synchronize the setting of the rising and falling slope values.
	Voltage/Current Limits	Voltage/Current Limit. When Operating in Priority is selected differently, different parameters are displayed.	
		+I-Limit/-I-Limit: Current positive and negative limit values.	
		+V-Limit/-V-Limit?: Voltage positive and negative limit values.	
		Tracking Limits: Positive and negative limit tracking: Select this option to synchronize the positive and negative limits.	

	Internal Resistance	When selecting the Operating in Priority as voltage, set the power supply internal resistance value.		
Measure	Measurement-related configurations.			
	Remote Sense	Remote: remote sense state. On: enable the remote sense Off: disable the remote sense		
	Meter I Range	Current meter range		
	Measurement			
		NPLC	Number Power Line Cycles	
		Aperture	Sampling frequency mode selection.	
		Time Interval	Time sampling mode	
		Line Frequency	AC power supply frequency	
		Points	Sampling points	
		Reset	Reset parameters	
	Whour & Ahour	Measurement of watt-hour and amp-hour parameters.		
	Auto clear after output on Clear			
Output	Voltage Bandwidth Range			
		Low		
		High1/ High2/ High3		
	Output turn off mode	Output status when output is disabled.		
		Highz		
Lowz				
Trigger	Trigger configurations			
	DC Setting	DC value setting Digital IO is PIN1~PIN7		
	Transient Trigger source	Transient system trigger Selectable trigger sources are Immediate Trigger, Bus, Manual Trigger and PIN1~PIN7 Digital IO Trigger.		
	Transient Trigger Out	When the transient selection outputs a trigger signal, the IO pin mapped to the class selection is pin 1 to pin 7.		
	Tout at the beginning of transient	When selecting a transient waveform, output a trigger signal externally at the start.		
	Tout at the end of transient	When the transient waveform ends, a trigger signal is output externally.		
Z-φ Measure	impedance testing			
	Impedance measurement Aperture	Impedance measurement aperture period.		
		Cycles: Measure the minimum cycle		

		Time(Min): Measure minimum time
	Impedance measurement Delay	Impedance measurement delay period
		Cycles: Measure the minimum cycle
		Time(Min): Measure the minimum cycle
	Impedance Function	Used to set the current measurement model to display the corresponding parameters on the meter interface.
Z-φ0Adjust	Zero adjustment during impedance testing.	
	Start	Start zeroing.
	Clear	Clear zeroing action.
	Open	Open the zeroing file
	Save	Save calibration files
	Delete	Delete zeroing files

3.7 System Menu

Press **[Shift] + [1]** (System) to enter the system menu, at this time the LCD shows the selectable function, use the up, down, left and right keys or touch to select and edit, the menu items are shown below.

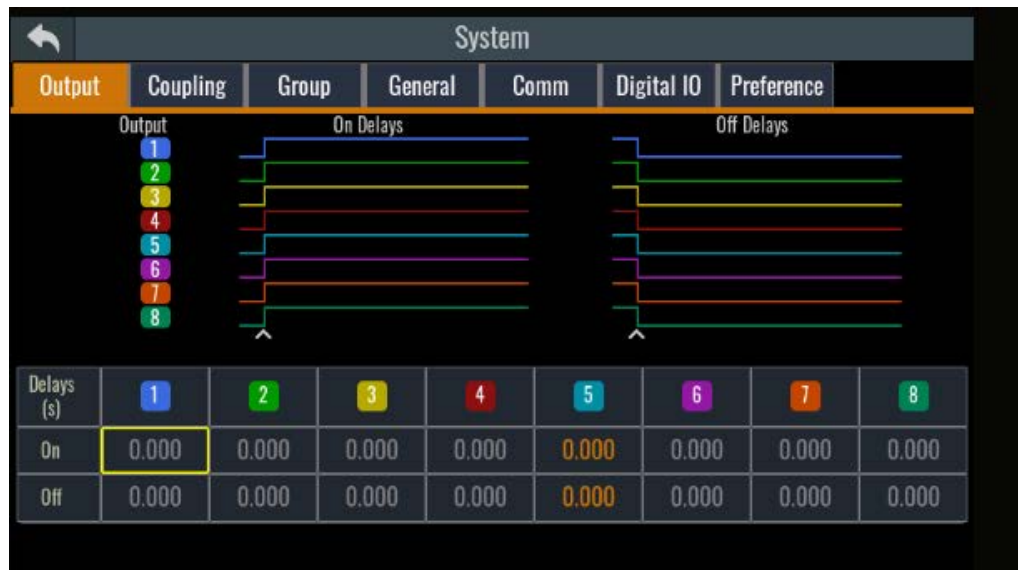

Output		
	Output On Delays	Voltage rise delay time setting when the output switch is turned on. Different channels can be set separately.
	Output Off Delays	Voltage drop delay time setting when the output switch is closed, different channels can be set separately.
Coupling		
	Output Coupling	Mode: Outputs are synchronized between channels. When Auto is selected, each channel is synchronized identically with the

		lowest delay time, and when Manual is selected, each channel output is synchronized according to the set value. Delay Offset: Output delay time between channels.
	Protect Coupling	
	Inhibit Coupling	Select the channel on which the IO inhibit function takes effect.
		Mode: Latch: The output cannot be automatically restored after the IO signal disables the output. Living: After the IO signal disables the output, it automatically restores the output as the signal changes. Off: disable this function
Group	Setting up parallel systems between channels	
	Group A With	Select the maseter. If the ch3 is select to be master, the CH4-CH8 can be select to parallel.
	Group B With	Select the maseter. If the ch3 is select to be master, the CH4-CH8 can be select to parallel.
General	General configurations	
	Power-on setup	the state of the AC source after power up
		Reset: he instrument will initialize some parameter settings or state
		Last: the instrument will remain the same parameter settings and output status as last time you powered off
		Last-off: the instrument will remain the same settings as last time you powered off the instrument, but the output status is Off .
	Source Slope Type	The type of slope setting, you can choose the slope value or the slew time.
	Factory Default Settings	Restore factory values. Click Reset to confirm.
	Load Current Symbol	Display symbol for current in load mode. Positive or negative can be selected.
	Output State After Protect Clear	Off: After removing the protective cover, the machine is in the off state. Auto: After clearing the protection, the machine returns to the state.
	System Reboot	System reboot.
Comm	USB Settings	USB type.
		Type:

		<ul style="list-style-type: none"> ● Device: The USB device is the communication interface. ● Host: USB devices are used for storage.
		Device Mode <ul style="list-style-type: none"> ● VCP ● TMC
	Lan Settings	Lan setting
		Mode: <ul style="list-style-type: none"> ● DHCP ● Manual
		IP Address
		Subnet Mask
		Socket Port
		MAC Address
		Gateway
		Apply
		Restore
	CAN Settings	CAN communication configuration
		Baud rate: Baud rate selection
		Address: Address settings
	Modbus	Modbus Reg
	Layout*Channel <ul style="list-style-type: none"> ● Sub ● Whole 	

IO Config Menu:

IO	Digital IO1:Remote Inhibit Input	Function setting of PIN1	
		Inverse	On/Off, Select Inverse or not If setting to ON, it means the valid signal is reversed.
		Function	<ul style="list-style-type: none"> ● Inhibit ● Digital-In ● Digital-Out ● Trig-in/Trig-out
	Digital IO2: PS	Function setting of PIN 2	
		Inverse	On/Off, Select Inverse or not If setting to ON, it means the valid signal is reversed.
		Function	<ul style="list-style-type: none"> ● PS ● Digital-In ● Digital-Out ● Trig-in/Trig-out
	Digital IO3: PS Clear	Function setting of PIN3	
		Inverse	On/Off, Select Inverse or not If setting to ON, it means the valid signal is reversed.

		Function	<ul style="list-style-type: none"> ● PS Clear ● Digital-In ● Digital-Out ● Trig-in/Trig-out
	Digital IO4: ON/OFF Status	Function setting of PIN4	
		Inverse	On/Off, Select Inverse or not If setting to ON, it means the valid signal is reversed.
		Function	<ul style="list-style-type: none"> ● ON/OFF Status ● Digital-In ● Digital-Out ● Trig-in/Trig-out
	Digital IO5: SYNC	Function setting of PIN5	
		Inverse	On/Off, Select Inverse or not If setting to ON, it means the valid signal is reversed.
		Function	<ul style="list-style-type: none"> ● Sync-in ● Sync-out ● Digital-In ● Digital-Out ● Trig-in/Trig-out
	Digital IO6: On-Couple	Function setting of PIN6	
		Inverse	On/Off, Select Inverse or not If setting to ON, it means the valid signal is reversed.
		Function	<ul style="list-style-type: none"> ● On-Couple ● Digital-In ● Digital-Out ● Trig-in/Trig-out
	Digital IO7: Off-Couple	Function setting of PIN7	
		Inverse	On/Off, Select Inverse or not If setting to ON, it means the valid signal is reversed.
		Function	<ul style="list-style-type: none"> ● Off-Couple ● Digital-In ● Digital-Out ● Trig-in/Trig-out
	Pulse Width	Range: 5us-500us, Input signal range: >5us	
	Digital IO: Status	IO port status and direction	
Preference	Buzzer	Set the keyboard sound.	
		Key	Buzzer on/off for key
		Alarm	Buzzer on/off for protect
	Brightness	Set the screen brightness.	
		1-10	Set the screen brightness level
	Touch Screen	Lock the touch screen function	
		Status	Set the ON/OFF state
	Knob immediately effective	Knob setting will take effect immediately. If set to ON, the Knob setting will take effect immediately. If set to	

		OFF, press ENTER to confirm the effect after the Knob setting is completed.	
	Language	Set the language of display	
		English	English
	Soft Panel	Set the soft keyboard	
		On	Turn on the soft keyboard.
		Off	Turn off the soft keyboard.
	Default Meter View	Meter1: Single view Meter4: 4 channel view Meter8: 8 channel view	
Date&Time	Date	Click Edit to reset the system date.	
	Time	Click Edit to reset the system time.	

3.8 On/Off Control

WARNING

- The **[On/Off]** key is used to turn the output on or off under normal circumstances. Even if the instrument is in control by PC or the keyboard is locked, the **[On/Off]** is still valid for turn off output.
- The **[On/Off]** key light is off and turning the output off does not place the instrument in a safe state. Hazardous voltages may be present on all output and guard terminals. Putting the equipment into an output-off state does not guarantee that the outputs are powered off if a hardware or software fault occurs. See the cautions about connecting the test lines before connecting test lines.

On/Off keyboard control output

You can press the **[On/Off]** key on the front panel to control the output status of the power supply. If the **[On/Off]** key light is on, indicates that the output is turned on. The VFD displays the meter value such as voltage, current, power and so on. If the **[On/Off]** key light is off, indicates that the output is turned off. The VFD displays that the power supply state is OFF.



Note

After the instrument is connected to the DUT, turn on the output. If there is no output voltage, please check the setting value of voltage and current, set both voltage and current to non-zero values, and then turn on the output.

Command control output

When remote status, the corresponding SCPI command can be used to control the On/Off switch of the power supply or load, the command refer to the describe in the Programming Guide.

Digital IO control output

The Digital IO pin, which comes standard with this series of instruments, supports the external level/pulse signal control output, in combination with external circuits, enables the input/output to be turned on and off. Refer to the Digital IO function introduction for details.

Chapter4 Operation and Application

4.1 Select Source Operation Mode

The IT2705 series power system can realize different functions by installing different modules. The module can be a power supply module or a load module, and when used as a DC power supply or Bidirectional power supply module, the operation mode can be selected as CV priority mode and CC priority mode:

CV priority mode

In CV priority mode, the output voltage should be set to the desired value. In addition, positive and negative current limit values should be set. The output is controlled by a constant-voltage feedback loop, which maintains the output voltage at its programmed setting as long as the load current remains within the positive or negative current limit settings.

If you want the output voltage to remain constant, select voltage priority. In voltage priority mode, set the output voltage to the desired value. Additionally, set the positive and negative current limit values. In voltage priority mode, the output is controlled by a constant voltage feedback loop, so as long as the current of the device under test remains within the positive/negative current limit settings, the output voltage can be maintained at its programmed setting.

The figure below shows the output operating trajectory in voltage priority mode. When in power supply mode, the output is in the white quadrant area. When the bidirectional power supply is in load mode, the output is in the shaded quadrant area.

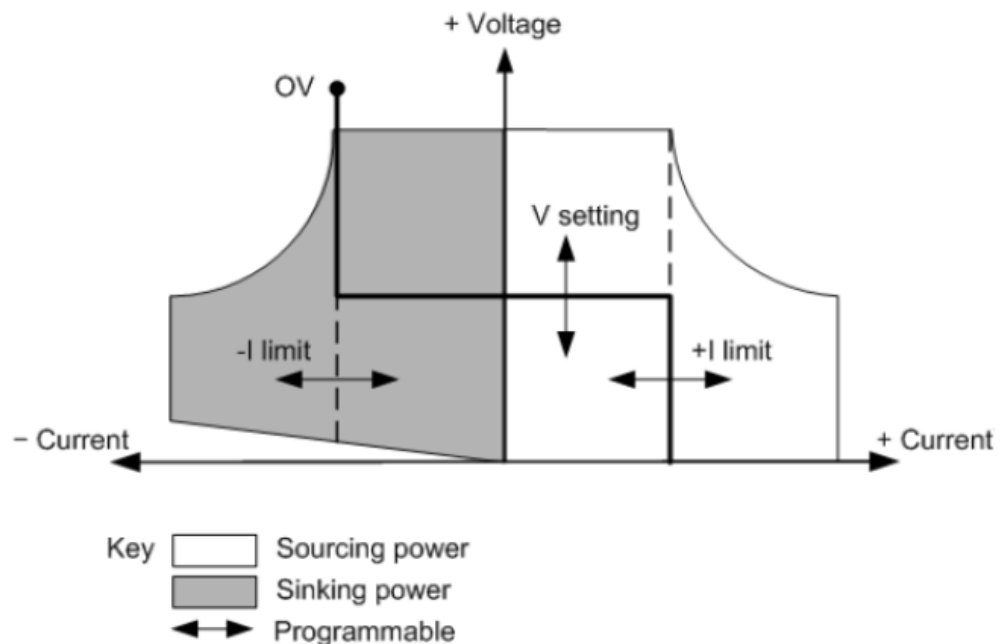

CC priority mode

If you want the output current to remain constant, select current priority. In current priority mode, you should set the output current to the desired positive or negative value and also set the voltage limit value. The voltage limit should

always be set higher than the actual input voltage requirement of the external device under test. In current priority mode, the output is controlled by a bipolar constant current feedback loop, which can maintain the output power supply or absorb the current output according to its preset settings. As long as the voltage of the device under test remains within the voltage limit setting range, the output current can be maintained at its programmed setting.

The figure below shows the output operating trajectory in current priority mode. When in power supply mode, the output is in the white quadrant area. When the bidirectional power supply is in load mode, the output is in the shaded quadrant area.

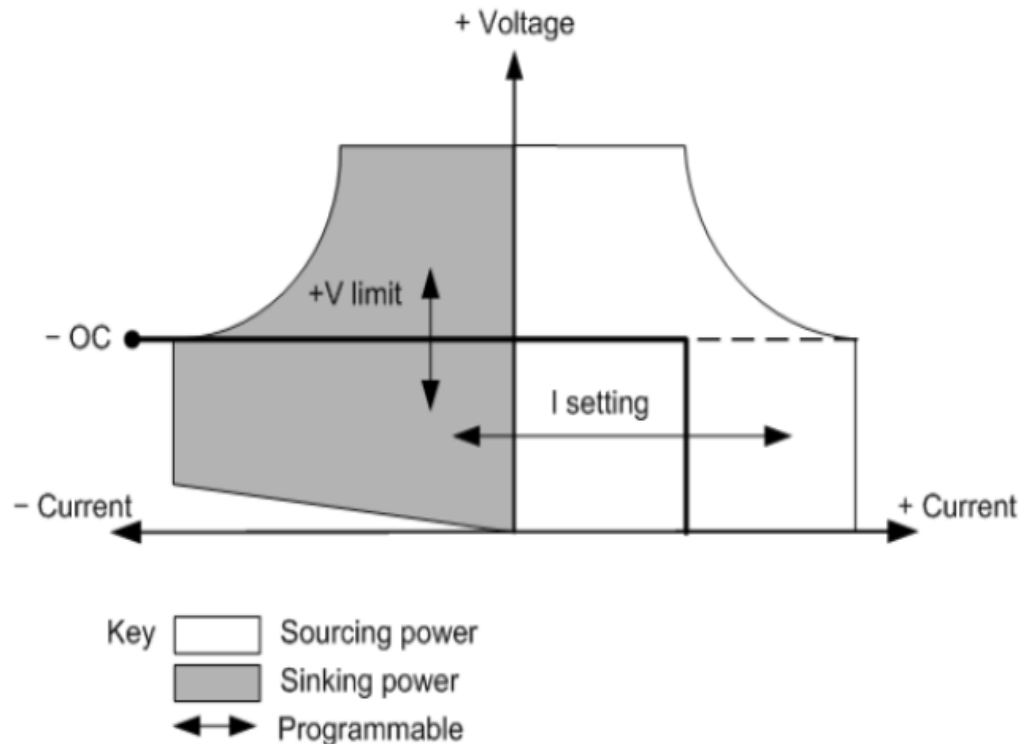

4.2 Select Load Operation Mode

The IT2705 series power system can realize different functions by installing different modules. The module can be a power module or a load module, and when used as a load, the operation modes include the following:

Basic Operation Mode

- CV: Constant Voltage Mode

Under CV mode, the electronic load will consume sufficient current to maintain the input voltage at setting voltage. As shown in the following figure. For battery chargers or charging stations, CV mode can change their output voltage to ensure the precision of the charging current.

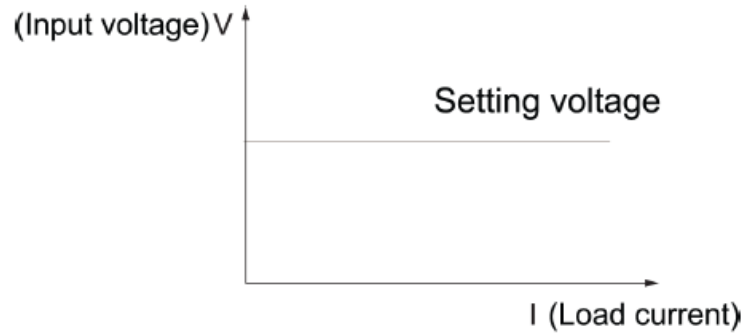

- CC: Constant Current Mode

Under CC mode, the electronic load will consume constant current in regardless of whether the input voltage changes or not, as shown in the following figure. The CC mode ensures that the UUT voltage outputs remain stable when the load varies.

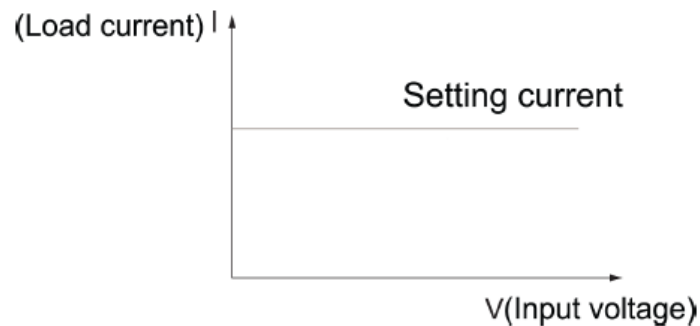

- CP: Constant Power Mode

Under CW mode, the electronic load will consume a constant power. If input voltage rises, the input current decreases and power $P (= V * I)$ will maintain at setting power. As shown in the following figure.

When the UUT is a battery, the electronic load changes to simulate device loading behavior. Many battery discharge applications and power consumption profiles can be simulated for analysis, making the CW mode the best choice for simulating electronic device loads.

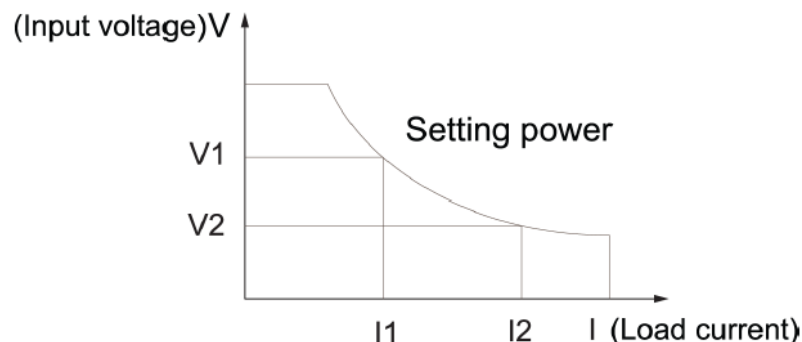

- CR: Constant Resistance Mode

Under CR mode, the electronic load is equivalent to a constant resistance and will give linear change of current with input voltage change. As shown in following figure. The CR mode ensures that the UUT voltage outputs remain stable when the load varies.

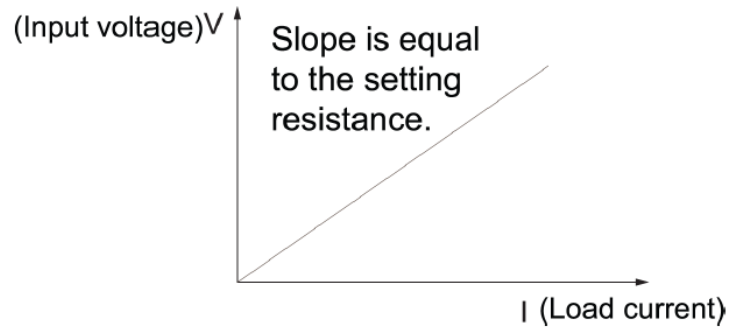

Complex Operation Mode

IT2700 series complex operating modes include CC+CV, CC+CR, CR+CV, CP+CV and CC+CP+CR+CV modes, which can satisfy a wide range of test requirements.

- CC+CV Mode

In CC+CV mode, it has to program the constant voltage and constant current first and then start the UUT for output. When the UUT voltage starts to output, the Load will sink in CV mode according to the programmed voltage.

When the voltage rises to exceed the set constant current for sinking, it will switch to CC mode for sinking. The CC+CV mode can be applied to the load simulation battery and test the charging station or the car charger. When the CV is working, the maximum loading current is limited.

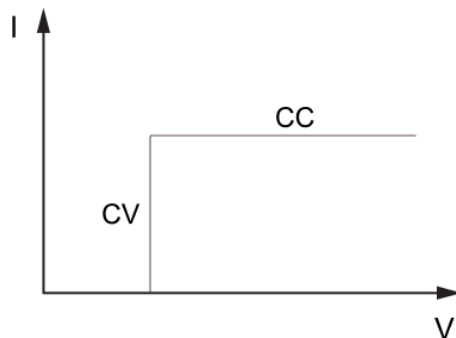

- CR+CV Mode

In CR+CV mode, it has to program the constant voltage and constant resistance first and then start the UUT for output. When the UUT voltage starts to output, the Load will sink in CV mode according to the programmed constant voltage. When the voltage rises to exceed the set constant resistance for sinking, it will switch to CR mode for sinking.

The CR+CV mode can be applied to the LED simulation and test the LED power supply to get the LED current ripple parameters.

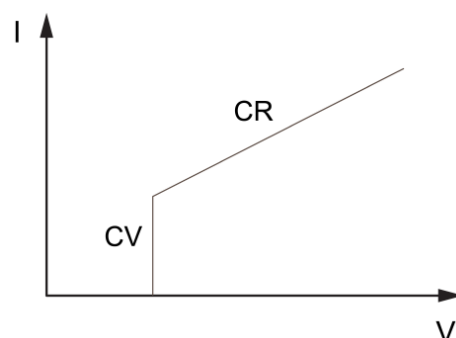

- **CC+CR Mode**

In CC+CR mode, it has to program the constant resistance and constant current first and then start the UUT for output. When the UUT voltage starts to output, the Load will sink in CR mode according to the programmed resistance.

When the voltage rises to exceed the set constant current for sinking, it will switch to CR mode for sinking. The CC+CR mode is commonly used in the testing of voltage limiting, current limiting characteristics, constant voltage accuracy, and constant current accuracy of on-board chargers, which prevents over-current protection of on-board chargers.

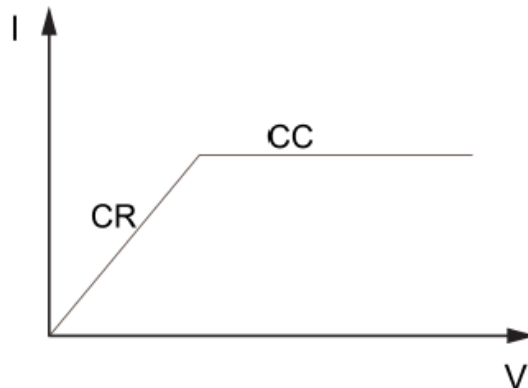

- **CP+CV Mode**

In CP+CV mode, it has to program the constant power and constant voltage first and then start the UUT for output. When the UUT voltage starts to output, the Load will sink in CV mode according to the programmed voltage. When the voltage rises to exceed the set constant power for sinking, it will switch to CP mode for sinking.

The CP+CV mode is often used to UPS battery test, simulate the current change when the battery voltage is decaying. It can also be used to simulate the characteristics of the inputs of DC-DC converters and inverters.

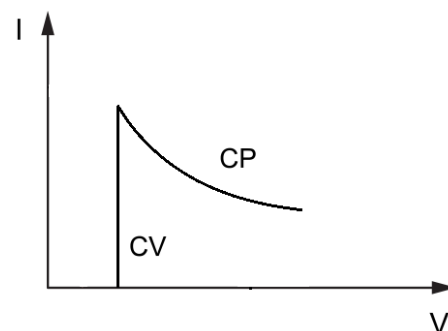

- **CC+CR+CP+CV**

constant current and constant power, and then start the UUT for output. When the UUT voltage starts to output, the Load will sink according to the programmed constant voltage in CV mode. When the voltage rises, it will automatically switch to CR mode and to the CC mode at last for sinking. It will switch to CW mode for sinking if the UUT outputs high voltage abnormally.

Under this mode, the load can automatically switch among CV, CR, CC and CP modes. It is suitable for lithium ion battery charger testing to get a complete V-I

charging curve. Moreover, the auto mode can avoid damaging the UUT when the protection circuit is damaged.

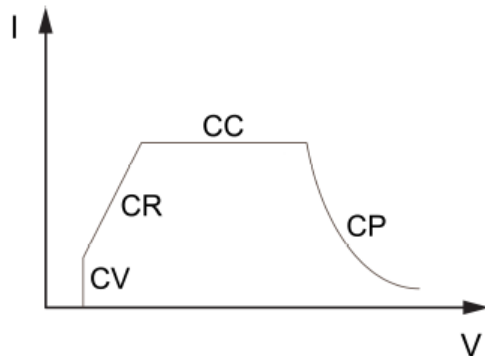

Battery simulation mode (BSIM)

This series load comes with a battery simulation mode, which is applicable to discharge function test for the charger. The user can directly select this mode in the configuration menu. In the charging principle of charger, after the charger is connected to the battery, monitor the battery voltage at first. If the battery connection is reliable and correct, the charger enters the charging state. When the instrument is under the battery simulation mode of load, an simulate battery voltage can be set, which has weak output capacity capable of outputting small current for simulating battery state. Thus, the charger's working requirements can be met.

In the configuration menu, if **Const Mode** is selected as **BSIM**, the load enters the battery simulation state. Press **Esc** to return to the main interface. At this moment, the **[V-set]** keys lights up. The user can set the voltage value and the upper limit of input current.

The load is in battery simulation mode and the current limit is the maximum current value for that model.

4.3 Selecting SMU Operation Mode

When the IT2705 Series Modular DC Power Analyzer is used in conjunction with the Source Measure Unit (SMU) module, select the SMU operating mode from the drop-down emulation list in the Config menu.

4.3.1 Multi-Quadrant Power Supply

When the multi-quadrant power supply mode is selected, the instrument output operates within the supported quadrant regions.

- 1Q Power Supply: Output operates in the first quadrant only. The instrument functions solely as a unidirectional power source.
- 2Q Power Supply: Output operates in the first and second quadrants. The instrument can function both as a power source and as an electronic load.
- 4Q Power Supply: The instrument output simulates a four-quadrant power supply, enabling bidirectional energy flow as well as AC output operation.

Voltage Priority Mode

In voltage priority mode, set the output voltage to the desired positive or negative value first. Then set both the positive and negative current limit values. The current limit should be set higher than the actual output current requirement of the external load. When Tracking is enabled, the negative current limit will follow

the positive current limit setting. When Tracking is disabled, you can set different positive and negative current limits.

The diagram below shows the voltage-priority operating trajectory. When functioning as a source, the output lies in the white quadrant areas. When functioning as a load, the output lies in the shaded quadrant areas.

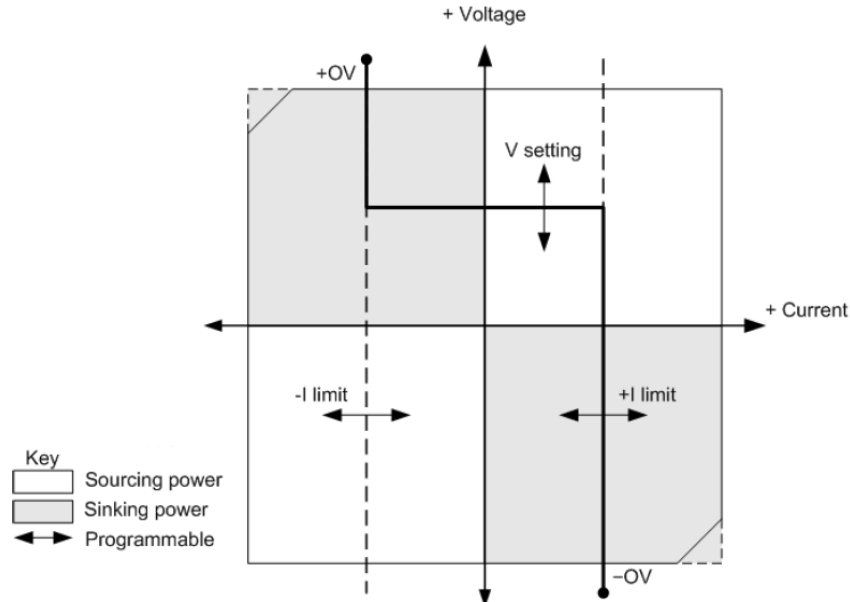

Current Priority Mode

In current priority mode, set the output current to the desired positive or negative value. Then set the positive voltage limit. The voltage limit should be set higher than the actual output voltage requirement of the external load. When Tracking is enabled, the negative voltage limit follows the positive voltage limit setting. When Tracking is disabled, you can set different positive and negative voltage limits.

The diagram below shows the current-priority operating trajectory for the power module. When functioning as a source, the output lies in the white quadrant areas. When functioning as a load, the output lies in the shaded quadrant areas.

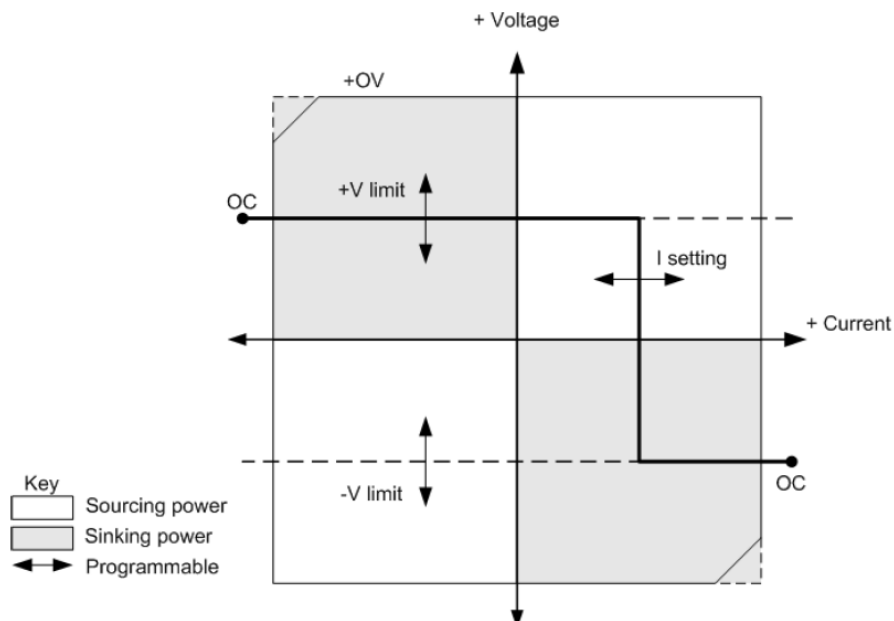

4.3.2 Range Selection

The SMU module supports multiple range settings. Different ranges affect the output accuracy. In the Config menu, highlight the Range field using the navigation keys, press Enter to access the drop-down range list, and select the desired output range with the navigation keys.

Once the desired range is selected, the set value will be restricted within that range.

4.3.3 Output Bandwidth

The source-load module offers several voltage bandwidth settings to optimize output response time according to the characteristics of capacitive loads. The Low bandwidth setting provides high stability over a wide capacitive load range. Other settings can deliver faster output response when the capacitive load is limited to smaller values.

Press the Config key to access the output window. Navigate and select the voltage bandwidth range.

Different gears are suitable for different capacitance parameters:

- 0–150 μF : Low
- 0–1 μF : High1
- 1–7 μF : High2
- 7–150 μF : High3

4.3.4 Load Modes

- Constant Current (CC) Load

Regardless of the input voltage, the load module sinks current according to the set value.

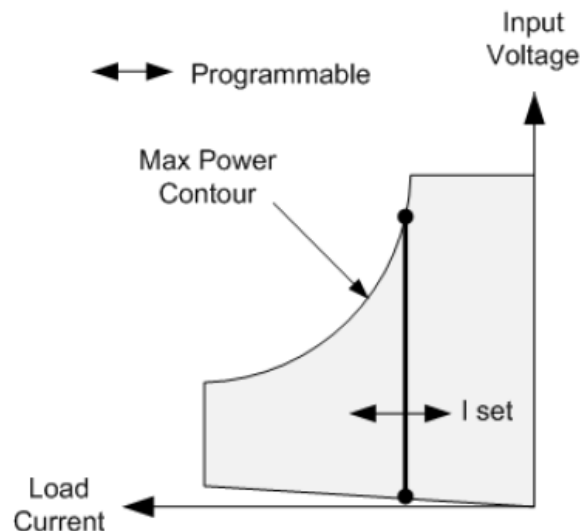

The heavy solid vertical line illustrates the locus of possible operating points as a function of the load current. A CC (constant current) status flag indicates that the load current is at the specified setting. In this mode, the current range can be selected, with a smaller range providing better setting resolution. A positive voltage limit can also be set.

- Constant Voltage (CV) Load

The load module sinks sufficient current to maintain the input voltage at the programmed value.

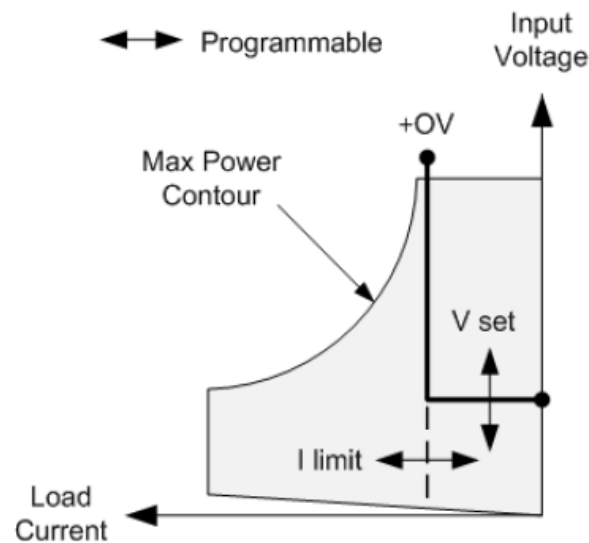

The heavy solid line illustrates the locus of possible operating points as a function of the load voltage.

Note that in voltage priority mode, a current limit can be imposed. As shown by the horizontal portion of the line, the input voltage remains regulated at its programmed setting as long as the input current remains within the current limit setting. In this mode, the current range can be selected, with a smaller range providing better setting resolution.

- Constant Resistance (CR) Load

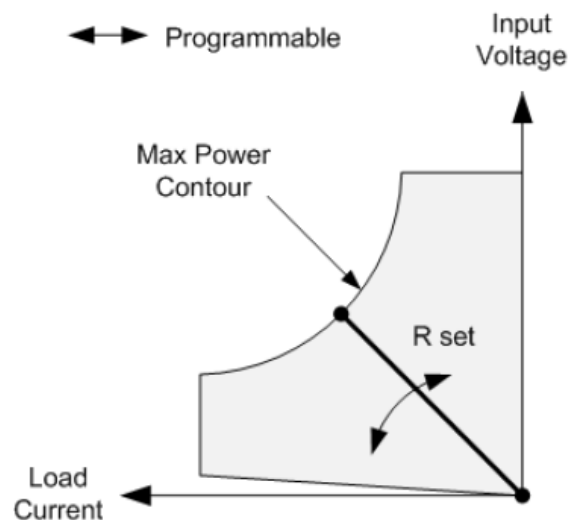

The heavy solid line illustrates the locus of possible operating points as a function of the resistance.

the load selects the range with the highest resolution for the resistance value.

- Voltmeter Mode
The SMU module operates as a voltmeter, measuring voltage and current parameters.
- Ammeter Mode
The SMU module operates as an ammeter, measuring voltage and current parameters.

- Battery Emulator
The SMU module operates as a battery simulator.
- Battery Charger
The SMU module operates as a battery charger.

4.4 Config Menu Function

IT2705 series instrument install different modules can realize different functions, different modules, config menu setup items are different, please refer to the Config menu introduction content for specific parameter introduction.

4.4.1 Setting Output Rise Time/Fall Time

Rise/fall time is the time taken for one voltage point to rise/fall to the other point under the output status is ON. The slope in source mode can be set as a ramp value or as a time value. Only the ramp value can be set in load mode.

The slope can be set in the Config menu or in the slope display on the left side of the screen in the Meter interface. The logic of the setting in the Meter interface is the same as that of the setting in the Config menu.

This power supply supports setting the rising and falling slopes in all modes.

1. Select “**Config**” > “**Source**” > “**Voltage/Current/Resistance/Power slew Rate Settings**”.
2. Each setting item can be selected by using the up and down arrow keys. The setting value can be adjusted by using the numeric keys or the knob, and confirmed by pressing [**Enter**] or the knob key when the input is finished.

If you need to modify the type of slope value of the power supply, please refer to the following way to enter the system menu to modify.

1. Press [**Shift**]+ [**1**](System) and enter to system menu.
 2. Select “**General**” > “**Source Slope Type**”.
- Time: Indicates that the slope setting value is a time value. Unit: s.
 - Slew: Indicates that the slope setting value is the change value per unit of time, and the unit is V/ms or A/ms depending on the mode.

4.4.2 Set the Internal Resistance (Source/SMU Module Support)

The IT2700 series power system provides internal resistance setting under CV priority mode. The procedures are shown as below.

1. Press the [**Config**] keys to enter the configuration menu.
2. Select **Internal Resistance** and check the box.
3. Use the numeric keys to enter the value of the internal resistance, then press the [**Enter**] key to confirm.

4.4.3 CR Function in Sink Mode (Bi-directional Module Support)

This series instrument supports CR testing in sink mode, and the sink current capability of CR is controlled by the Is setting value in CC priority mode.

The usage of this function is as follows:

1. Press [**Config**] enter the configuration menu.
2. Set **Priority** to Current.
3. Check Sink Resistance box, enable the CR mode in Sink.

4. Set the Sink Res value and press **[Enter]**.

The following takes the setting of 10Ω as an example to introduce the actual test results.

3. Set the voltage and current.
 - a. Press the [I-set] key on the front panel to set the output current value Is. Take 5A as an example.
 - b. Set V-High=20V and V-Low=0V under configuration menu.
 - c. Set the DUT (power supply) to output 80V, 10A.

At this time, 10Ω in sink mode (according to the formula $I=U/R$, sink current is $80\div 10=8A$), due to the limitation of $I_s=5A$ in CC priority mode, the actual sink current is 5A, and the instrument is working In CC mode. If Sink Res is set to 20Ω, the sink current is 4A, which is within the limit of Iset, so the instrument works in CR mode at this time.

4.4.4 Setting the Power Relay Lock Status(Source Module Support)

The IT2700 output is installed with a power relay, this power relay supports the function of DUT reverse connection judgment before closing, this function can realize anti-reverse connection and anti-surge.

The different states are described below, and users can choose according to their needs.

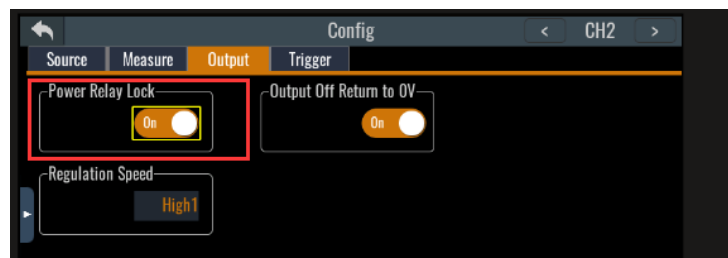

- On state

In this state, the power relay is in constant closed state, and there is no precharge and reverse connection judgment when the output is turn on (On/Off lights up), and the power supply output speed will be faster.

When the output is turn off (On/Off lights out), the power relay is also closed, and the internal circuit of the IT2700 series instrument and the DUT circuit are not completely disconnected. In this case, the energy storage DUT will be discharged.

- Off state

In this state, the power relay state is switched with the On/Off key, and when the output is turn on (On/Off lights up), it first performs precharge and reverse connection judgment, and if the DUT is reversed, reverse connection protection is reported and the output cannot be turn on.

If no reverse connection condition is detected, the power relay is closed to start output. When the output is turn off (On/Off lights out), the power relay is opened, and internal circuit of the IT2700 series instrument and the DUT circuit are completely disconnected. The power supply output will be 100ms slower in this state.

4.4.5 Output Turn Off Mode (SMU Module Support)

This series of SMU modules supports configuring output shutdown modes. Within the configuration menu, you can select whether the output state during shutdown is high-impedance mode or low-impedance mode.

- Highz: Indicates that the relay disconnects when the output is turned off.
- Lowz: Indicates that the relay remains energized when the output is turned off.

4.4.6 Under Voltage Inhibit (Load Module Support)

When testing some power products with slow voltage rise speed, if the electronic load input is opened before power, the power may latch protection.

In this way, the user may set Voltage on value and Voltage off value. The electronic load only latches when power voltage is higher than this value and when the power voltage is less the value of Voltage off, it stops to carry the load.

- Off: disable this function
- Live: Changes the load status in real time following the voltage change. When the voltage reaches the value of Voltage on, it starts to carry the load, and when the voltage reaches the value of Voltage off, it stops to carry the load.
- Latching: The load state does not follow the voltage change and starts to load when the voltage reaches the Voltage on value.

4.4.7 Short-circuit Analog Function (Load Module Support)

The electronic load can analog a short circuit. On the config menu check the box front of **Enable Short** to switch to the short circuit mode. The short circuit mode does not influence the existing settings. When the box front of **Enable Short** is unchecked, the instrument returns to the previous setting status.

In the short circuit mode, the current value is determined by the operation mode and the current range. Under CC, CP and CR modes, maximum short-circuit current is 110% of the current range. Under CV mode, short-circuit current equals to current when constant voltage is 0 V.

4.5 Protection Function

The IT2705 series power system has different protection menus when using different modules.

Press [**Protect**] button or click **Protect** function in Menu to enter Protect Configuration interface, the menu list and introduction of Protect function are shown below.

Source mode

Over Voltage Protection		
	Voltage	OVP point
	Delay	OVP delay time, range: 0.000s-10s.
Over Current Protection		
	±Current	OCP point
	Delay	OCP delay time ,range: 0.000s-10s.
Over Power Protection		
	±Power	OPP Point
	Delay	OPP delay time, range: 0.000s-10s.
Under Voltage Protection		

	Voltage	UVP point
	Warm	UVP Warm time, range: 0.000s-30s.
	Delay	UVP delay time, range: 0.000s-10s.
Under Current Protection		
	+Current	Positive UCP point
	-Current	Negative UCP point
	Warm	UCP Warm time, range: 0.000s-30s.
	Delay	UCP delay time, range: 0.000s-10s.
Foldback		
	Mode	OFF: foldback function is turned off. CV to CCCP: it indicates that the instrument triggers protection when the CV mode is switched to CC /CP mode. CC to CVCP: it indicates that the instrument triggers protection when the CC mode is switched to CV /CP mode.
	Delay	Foldback protection delay time.

Load Mode:

Over Current Protection		
	Current	OCP point
	Delay	OCP delay time, range: 0.000s-10s.
Over Power Protection		
	Power	OPP point
	Delay	OPP delay time, range: 0.000s-10s.

SMU Load

Over Voltage Protection		
	±Voltage	OVP point
	Delay	OVP delay time, range: 0.000s-10s.
Over Current Protection		
	±Current	OCP point
	Delay	OCP delay time, range: 0.000s-10s.
Under Voltage Protection		
	±Voltage	UVP point
	Warm	UVP Warm time, range: 0.000s-30s.
	Delay	UVP delay time, range: 0.000s-10s.
Foldback		
	Mode	OFF: foldback function is turned off. CV to CCCP: it indicates that

		the instrument triggers protection when the CV mode is switched to CC /CP mode. CC to CVCP: it indicates that the instrument triggers protection when the CC mode is switched to CV /CP mode.
	Delay	Foldback protection delay time.

4.5.1 Over Voltage Protection (OVP)

Users can enable the OVP function and set the protection limit Level and protection delay time. When the voltage (i.e., the Meter value) is greater than this protection limit and the delay time is exceeded, the power supply will enter the OVP state.

Possible Cause

Many reasons can cause OVP, the details are as follows:

- The set protection limit Level is lower than the voltage Meter value.
- The external (AC input) inputs a higher voltage.
- The power supply outputs a high voltage due to a fault.

WARNING

Please avoid inputting an external voltage higher than 120% rated value, or the instrument will be damaged.

How to Set

1. Press **[Protect]** to enter the Protect function setup interface.
2. Set the protection limit Level and the delay time Delay in sequence, and press **[Enter]** to confirm.

4.5.2 Over Current Protection (OCP)

Users can enable the OCP function and set the protection limit Level and protection delay time. When the current (i.e., the Meter value) is greater than this protection limit and the delay time is exceeded, the power supply will enter the OCP state.

Possible Cause

Many reasons can cause OCP, the details are as follows:

- The set protection limit Level is lower than the current Meter value.
- The external (AC input) inputs a higher current.
- The power supply outputs a high current due to a fault.

How to Set

The operation steps to set OCP are as follows.

1. Press **[Protect]** to enter the Protect function setup interface.
2. Set the protection limit Level and the delay time Delay in sequence, and press **[Enter]** to confirm.

For bi-directional power supplies, Level can be set to a positive or negative value, i.e. the same protection limit is set for the output or input current.

4.5.3 Over Power Protection (OPP)

Users can enable the OPP function and set the protection limit Level and protection delay time. When the power (i.e., the Meter value) is greater than this protection limit and the delay time is exceeded, the power supply will enter the OPP state.

Possible Cause

Many reasons can cause OPP, the details are as follows:

- The set protection limit Level is lower than the power Meter value.
- The power supply outputs a high power due to a fault.

How to Set

The operation steps to set OCP are as follows.

1. Press **[Protect]** to enter the Protect function setup interface.
2. Set the protection limit Level and the delay time Delay in sequence, and press **[Enter]** to confirm.

For bi-directional power supplies, Level can be set to a positive or negative value, i.e. the same protection limit is set for the output or input power.

4.5.4 Under Current Protection (UCP)

Users can enable the UCP function and set the instrument warm-up time, protection limit Level and protection delay time. When the current (i.e., the Meter value) is lower than this protection limit and the warm time, delay time are exceeded, the power supply will enter the UCP state.

Possible Cause

Many reasons can cause UCP, the details are as follows:

- The set protection limit Level is greater than the current Meter value.
- The external (AC input) inputs a lower current.
- The power supply outputs a low current due to a fault.

How to Set

1. Press **[Protect]** to enter the Protect function setup interface.
2. Set the warm time, protection limit point and delay time in sequence, and then press **[Enter]** to confirm.

For bi-directional power supplies, Level can be set to a positive or negative value, i.e. the same protection limit is set for the output or input current.

4.5.5 Under Voltage Protection (UVP)

Users can enable the UVP function and set the instrument warm time, protection limit Level and protection delay time. When the voltage (i.e., the Meter value) is lower than this protection limit and the warm time, delay time are exceeded, the

power supply will enter the UVP state.

Possible Cause

Many reasons can cause UVP, the details are as follows:

- The set protection limit Level is greater than the voltage Meter value.
- The external (AC input) inputs a lower voltage.
- The power supply outputs a low voltage due to a fault.

How to Set

1. Press **[Protect]** to enter the Protect function setup interface.
2. Set the warm time, protection limit point and delay time in sequence, and then press **[Enter]** to confirm.

4.5.6 Over Temperature Protection (OTP)

When internal temperature of instrument is higher than about 90 °C, the instrument enters temperature protection state. At this time, the instrument will automatically be OFF and the screen prompts OTP.

Possible Cause

To prevent damaging heat build-up and ensure specified performance, make sure there is adequate ventilation and air flow around the instrument to ensure proper cooling. Do not cover the ventilation holes on the rear panel, sides, or bottom of the instrument. Even with proper ventilation, the instrument can overheat in the following situations.

- If the ambient temperature is too high.
- If you use the instrument to test for long periods.

How to Set

The OTP limit does not need to be set, and the internal device of the instrument automatically detects and determines whether to enter the OTP state. If an over-temperature condition occurs, power off the instrument and allow it to cool for at least 30 minutes. After the internal temperature of the instrument has cooled down, power it on again.

CAUTION

When you return power to the instrument, verify that the cooling fan is running. If not, please contact ITECH Technical Support. Leaving the instrument powered on with an inoperative cooling fan may result in damage to the instrument.

4.5.7 foldback protection

This series instrument comes with Foldback protection function for turning off the output during CV/CC switch of the power supply to protect DUT sensitive to voltage overshoot or current overshoot. Foldback protection allows users to specify a working mode and set protection delay time. If there is any switch between existing working modes, the protection is triggered and the output is turned off from the time when the working loop switches to trigger protection and the delay time depletes.

- Enable FOLDBACK function;

- The existing loop is switched to set working mode, and the duration is longer than the set protection delay time;

Protection Cause

When the load voltage and current change, the instrument's operating mode switches automatically.

Delay FOLDBACK

You can specify a time for FOLDBACK delay so that the instrument can omit transient change of running mode within the specified delay range. In most cases, this transient condition is not deemed as switch state. At this moment, it is unnecessary to trigger the foldback function and disable output. Once the FOLDBACK delay time is exceeded, the output is turned off.

4.5.8 Sense Protection

When the Remote Measurement function is enabled, instrument defaults to provide sense protection. The premise is that the Sense switch is turned on. When the output state is ON and the difference between output terminal voltage and sense remote voltage exceeds the specified voltage, sense protection will be enabled after 2s. The instrument output will be immediately switched to Off and the display screen will display SENSE protect. When the instrument is in Sense Protection state, you should check whether the polarities are connected reversely or not firstly. If yes, you can reopen the output after the polarities connect correctly.

The voltage difference between output terminal and remote sense terminal of each model is not the same. the maximum voltage will not exceed the sum of output terminal voltage and the difference voltage.

The sense protection value for each model is identical to the sense compensation voltage value. For details, refer to the specification sheet. The maximum voltage during sense abnormality will not exceed the sum of the output terminal voltage and the sense compensation voltage value.

4.6 Timing Output Function

Up to 8 modules can be installed in the IT2705 series power system. On delay or Off delay can be set for different channels, through which timing outputs between multiple channels can be realized.

The user enters the System menu, selects the Output menu, and the output delay times for the channels are displayed at the bottom of the interface. Users can enter the corresponding On/Off delays as shown in the figure below.

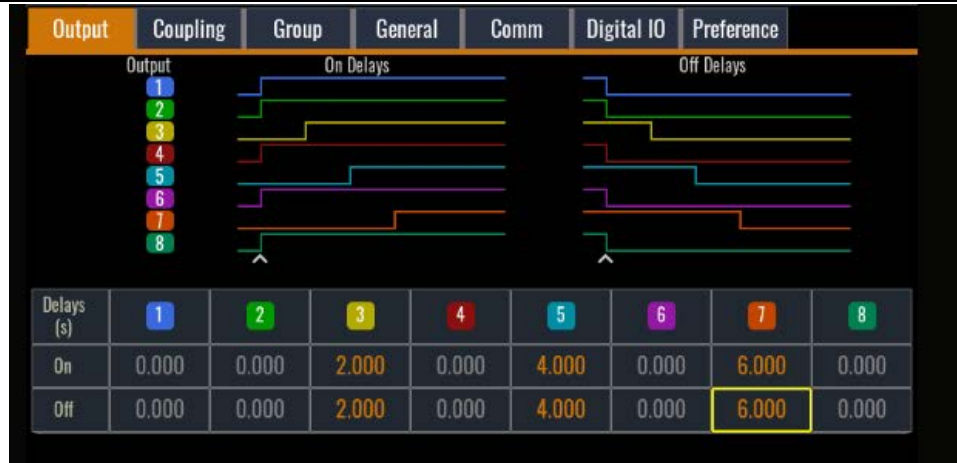

This function can be used to control the output delay of independent channels. It can also be used in combination with the ALL ON or ALL OFF key to realize the timing output between channels.

4.7 Channel Synchronized Output Function

Output synchronization can be selected between multiple channels of the IT2705 series instrument, and channels 1-8 can be selected to be fully synchronized or partially synchronized, which can be ticked by the user.

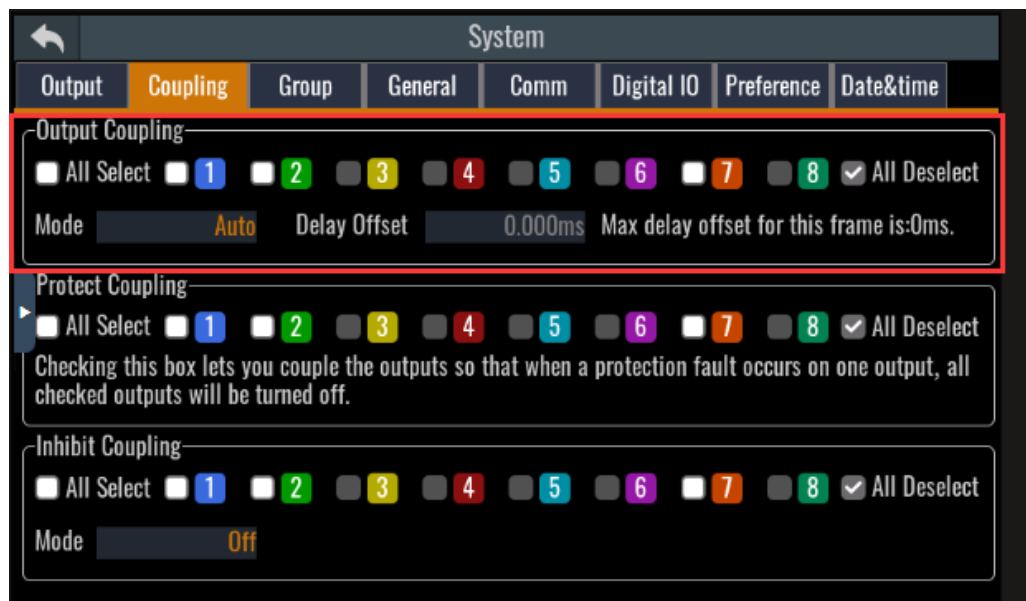

When Auto is selected as the mode, the instrument adjusts the delay time between the channels by itself. when Manual is selected, the user needs to set the delay Offset. This delay offset is superimposed with the On Delay and Off delay of each channel, and the final output schematic is shown below.

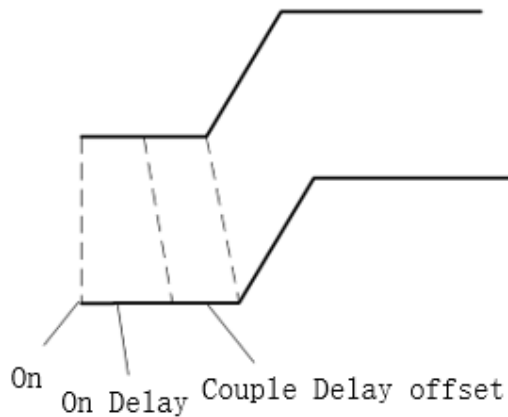

4.8 Parallel of Channels in the Main Frame

The modules in the IT2705 mainframe support parallel connection between them, which is used to extend the output power of the instrument, and the parallel connection requires that the module models are exactly the same. Up to 8 modules can be connected in parallel.

Different host frames do not support master-slave parallel connection.

Two sets of parallel relationships can exist in the one mainframe, and each channel can choose to join this parallel group. If it is not joined, it will be used as an independent channel.

Take CH1 and CH5 in parallel as an example to introduce how to set up the parallel group and use the parallel function.

Connecting Parallel Outputs

Determine the channel outputs that need to be connected in parallel, and connect that channel's output wires in parallel to DUT connect terminals.

Setting Parallel Relationship

1. The user enters the System menu, selects the Group menu, and the parallel system configuration interface as shown in the following figure:

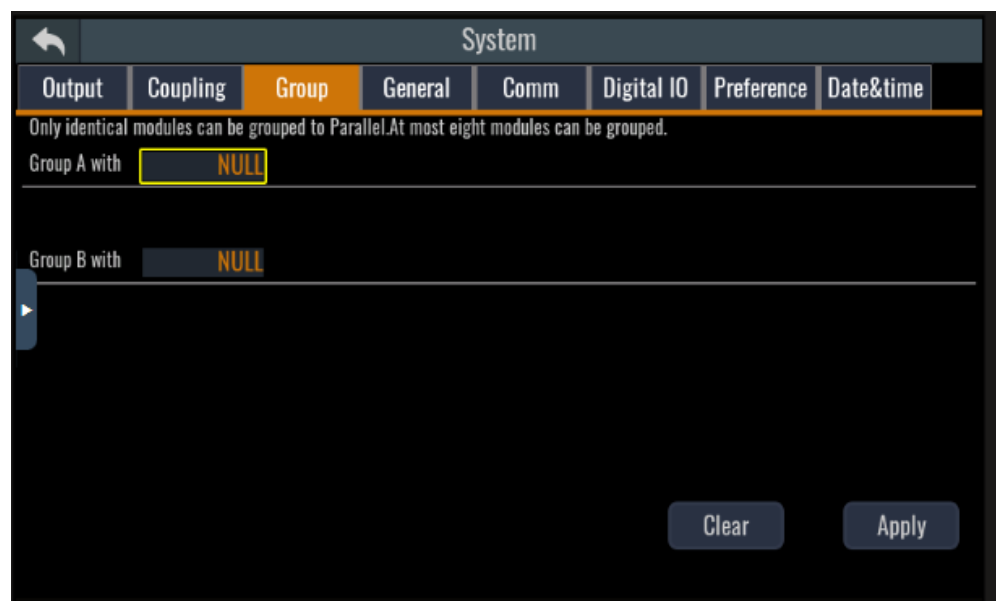

- Click **Group A with** corresponding input box, select the host role in the pop-up dialog box.

the host role selects the small channel number. CH1 and CH5 are paralleled, CH1 is selected as the host, and after the host role is selected, the instrument automatically filters the channel numbers in CH2-CH8 for paralleling. If CH5 is the host, the instrument automatically filters the channel numbers in CH6-CH8 for paralleling.

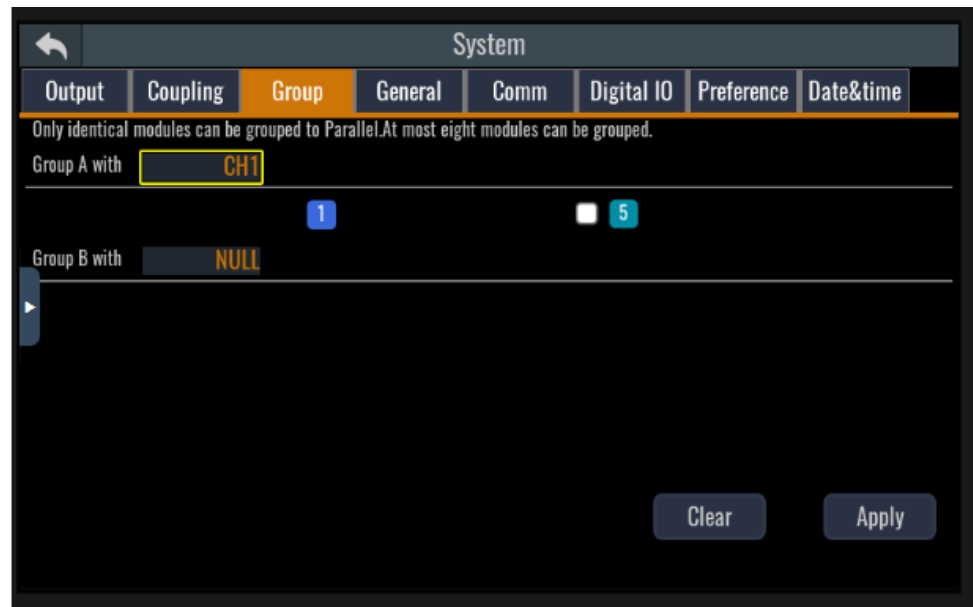

- Check the box in front of CH5, click Apply.
- Return to the main screen, CH5 will be displayed as a slave, and the output settings will operate only CH1.

Chapter5 Generating Arbitrary Waveforms

This chapter will introduce the List, ARB, Sequence, CDARB, Sweep, Battery Simulation, Battery Charge, Battery Discharge and transient(Load mode) functions of the IT2705 series instruments.

Selecting Fixed Mode under the Function Menu indicates exiting the present function mode and returning to normal output mode.

5.1 LIST

The IT2705 series module DC power analyzer's list function allows you to set up to 1024 steps per file. You need to edit the voltage/current value, slope, and duration of each step, and you can also set the number of times each list file is to be executed in a loop (0 to 65535). After completing the list file editing, you can trigger the selected list file to run according to the set trigger method.

5.1.1 Create a New List file

Users can create a new List file to output a list of waveforms with different amplitudes. The specific operation steps are as follows:

1. Press the **[Function]** key on the front panel to enter the advanced function selection interface, and click the List function icon to enter the list configuration interface.



Parameter	Discription
Trig source	The trigger source for list file running can be set to Immediate, Manual, Bus, PIN1~PIN7.
Repeat	The number of times the List file loops, 0 means infinite loops, the maximum number of loops is 65535.
Step	The number of steps present running.
Run	Run the List file.
Open	Open an existing List file
New	Create a new list file
Edit	Edit the list file.
Delete	Delete the List file. After deletion, the file name will be deleted and the display parameters will be retained.

2. Press [**New**] icon and create a list file.



Parameter	Discription
Priority	Select the voltage/current/power/resistance attribute of the list.
Repeat	The number of times the List file loops, 0 means infinite loops, the maximum number of loops is 65535.
End	The output state at the end of List file. It can be set to Normal, Last, Off. Normal: jumps to the output state in Fix mode, Last: keeps the last step parameter output, Off: closes the output.
Pacing	Method of step jumps to next step. Auto: when the time is out, jumps to next step. Trig: receive a trigger signal, jumps to next step.
Insert	Insert a step after the last step.
Delete	Delete the step.
Clear	Clear all step.
Open	Open an existing List file.
New	Create a new list file.
Save	Save an existing list file.
Save as	Name and save the newly edited List file.
Delete	Delete the list file.
No.	List step number
Voltage	Step value
Slew	Rise slope
Times	width time for the step.
BOStep	Output a trigger signal before the step
EOStep	Output a trigger signal after the step

3. Click **[Save]** and Save list file.
4. Press Return and return to the main screen, ready to run the List file.

5.1.2 Open /Run List

If you have already edited the List file, you can directly recall the List file and execute the test as follows:

1. Press the [Function] key on the front panel to enter the advanced function selection interface, and click the List function icon to enter the list configuration interface.
2. Press the **[Open]** key to select the file storage location, click Local or USB.
3. Select the channel and check the List file saved under that channel, and press the **[Open]** key to confirm the recall.
4. Press the front panel **[On/Off]** key to turn on that channel output.
5. Click Run in the list screen.

on screen displays the runtime and the list indicator.

5.1.3 Import/Export List File

Import List file

IT2700 series support import list file function, The user can finish the editing of List file in Excel and import it into the software. This function simplifies the List file edit and facilitates user operation.

To help user define an Excel file format, please export a CSV template from the List interface.

Detailed operation steps are as below:

1. Create a new Excel document on local PC and name it List02.
2. Open the Excel document and save it as in “other formats” i.e. “(*.csv)”.
3. Open the List02.csv document and edit the List. Set every step of the List and corresponding parameters and save the document in the USB disk.
4. Insert the USB disk into the USB interface of the front panel.
5. Press the **[Function]** key on the front panel to enter the advanced function selection interface, then click the List function icon to enter the list configuration interface.
6. Press **[Open]** to enter the List function configuration interface.
7. Select the List02.csv file and open it. The List file will be imported.

Export List file

After editing the List file, the user can directly save it into the device or export and save it into the peripheral memory disc. The exported List is saved in the format of. (*.csv). Detailed operation steps are as below

1. Insert the U disk into the USB interface of the front panel.
2. Press **[Function]** on the front panel to enter the List function configuration interface.
3. Select **[New]**, enter to list file edit interface.
4. Press **[Save as]**. This file will be exported into the USB disk.

5.2 Generating Arbitrary Waveforms (ARB)

Each output on the power system can be modulated by the built-in arbitrary waveform generator function. This allows the output to act as a DC bias transient generator or an arbitrary waveform generator.

5.2.1 Run the Arb Waveform

1. Press the **[Function]** icon on the menu to enter the advanced function selection interface, and click the Arb function icon to enter the arbitrary waveform configuration interface.



2. In this interface, the user can directly click Run, and the machine will output according to the waveform parameters displayed at the left of the interface.
If you need to run it in trigger mode, select the trigger mode in the trigger source on the left.

5.2.2 Setting the Arb Waveform Common Parameters

Under the Arb function, click the **[Edit]** button in the interface to enter the arbitrary waveform editing interface.

Select the corresponding waveform type and edit the parameters directly in the instrument interface to realize the output of different waveform shapes. This method does not need to save, but can be run directly after modification.

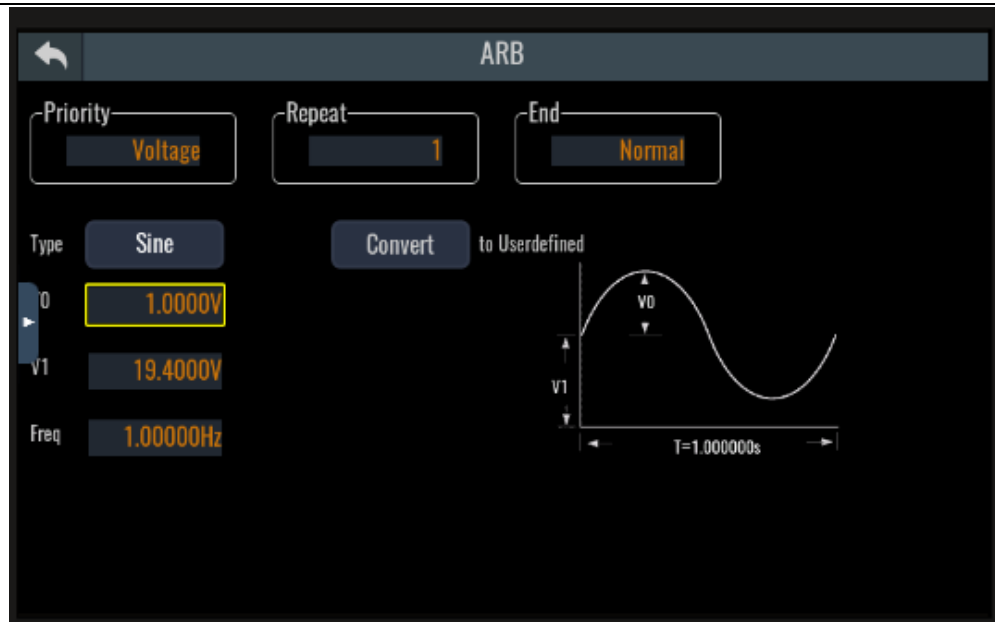

Parameter	Description
Priority	Select the voltage/current/power/resistance attribute of the Arb, when different output attributes are selected, the waveform definition parameters are different, for example, when Voltage is selected, V0 and V1 are set, if Current is selected, I0 and I1 are set.
Repeat	The number of times the Arb file loops, 0 means infinite loops, the maximum number of loops is 65535.
End	The output state at the end of List file. It can be set to Normal, Last, Off. Normal: jumps to the output state in Fix mode, Last: keeps the last step parameter output, Off: closes the output.
Type	Arb waveform type: Sine, Step, Pulse, Ramp, Trapezoid, Staircase, Exponential, Userdefined.

5.2.3 Configuring Step Arb

1. Press the [Function] icon on the menu to enter the advanced function selection interface, and click the Arb function icon to enter the arbitrary waveform configuration interface.
2. Select the Priority attribute.
3. Click the button corresponding to Type, select Arb type in the pop-up box to Step.

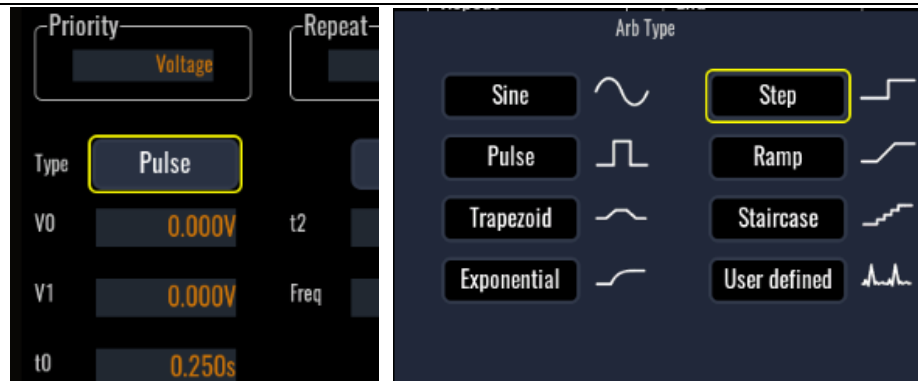

4. Configure the Step Properties.

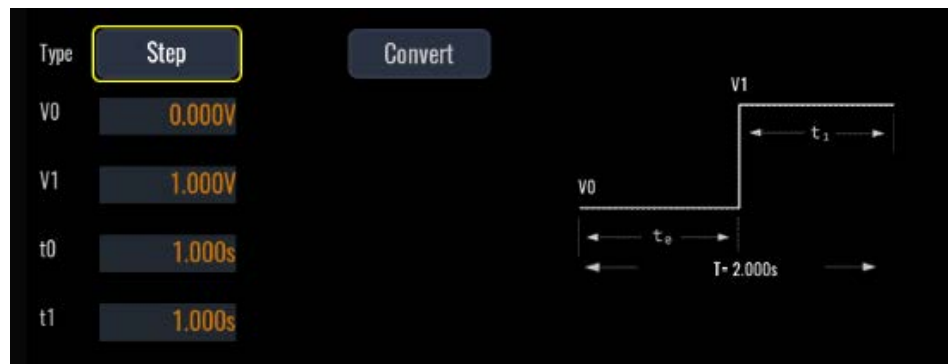

Parameter	Description
V0/ I0	The setting before the step.
V1/ I1	The setting after the step.
t0	The delay after the trigger is received but before the step occurs.
t1	The time the output remains at the end setting after the step occurs.

5.2.4 Configuring Ramp Arbs

1. Press the **[Function]** icon on the menu to enter the advanced function selection interface, and click the Arb function icon to enter the arbitrary waveform configuration interface.
2. Select the Priority attribute.
3. Click the button corresponding to Type, select Arb type in the pop-up box to Ramp.

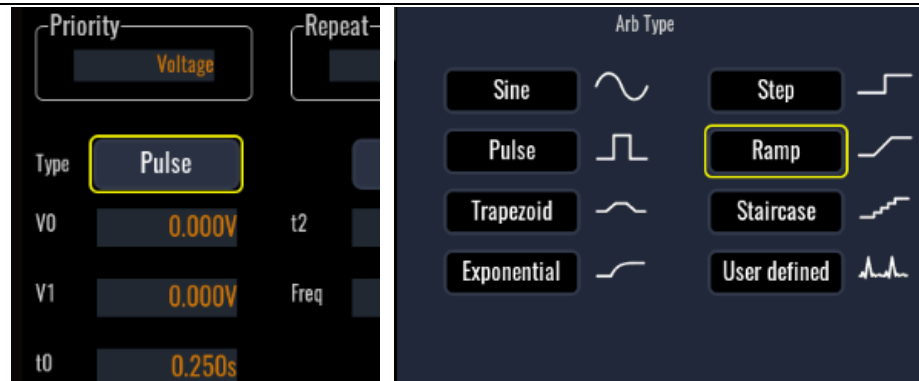

4. Configure the Ramp Properties.



Parameter	Description
V0/ I0	The setting before the ramp.
V1/ I1	The setting after the ramp.
t0	The delay after the trigger is received but before the ramp starts.
t1	The time that the output ramps up.
t2	The time the output remains at the end setting after the ramp completes.

5.2.5 Configuring Staircase Arbs

1. Press the [Function] icon on the menu to enter the advanced function selection interface, and click the Arb function icon to enter the arbitrary waveform configuration interface.
2. Select the Priority attribute.
3. Click the button corresponding to Type, select Arb type in the pop-up box to Staircase.

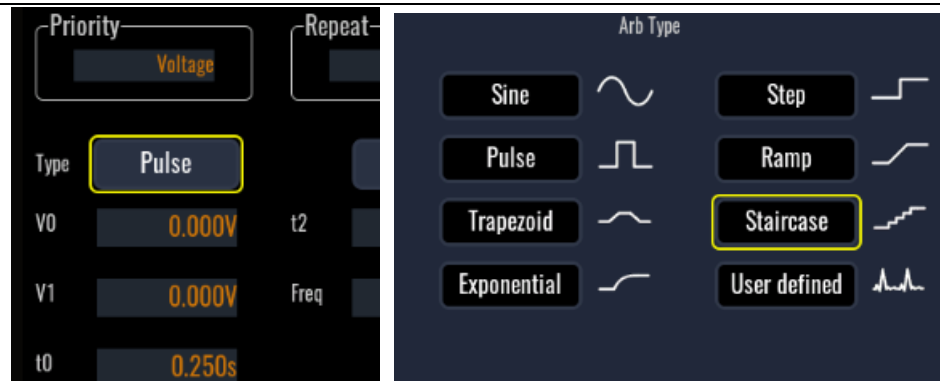

4. Configure the Staircase Properties.

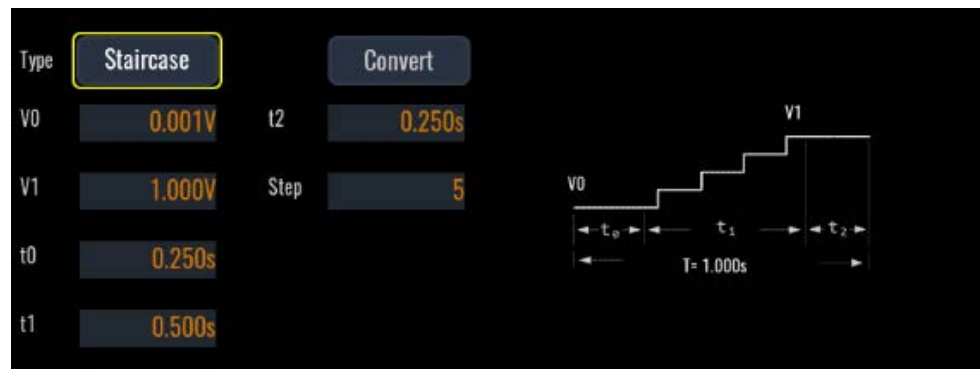

Parameter	Description
V0/ I0	The setting before the staircase.
V1/ I1	The setting after the final step. The difference between the start and end setting is divided equally between steps.
t0	The delay after the trigger is received but before the staircase starts.
t1	The time to complete all staircase steps.
t2	The time the output remains at the end setting after the staircase completes.
Step	The total number of staircase steps.

5.2.6 Configuring Sine Arb

1. Press the [**Function**] icon on the menu to enter the advanced function selection interface, and click the Arb function icon to enter the arbitrary waveform configuration interface.
2. Select the Priority attribute.
3. Click the button corresponding to Type, select Arb type in the pop-up box to Sine.

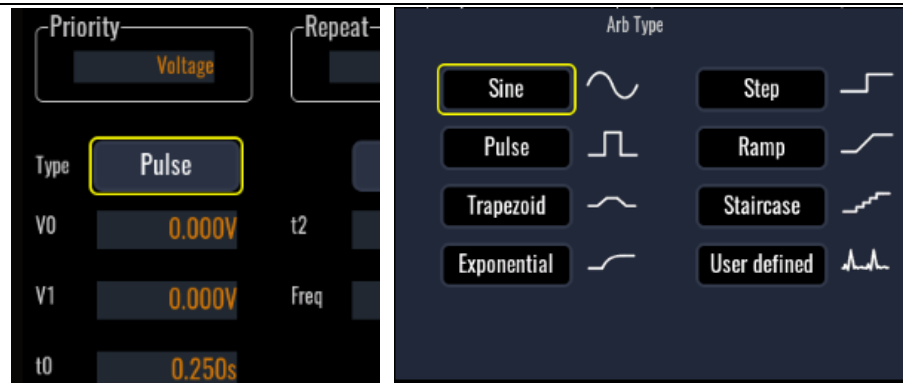

4. Configure the Sine Properties.

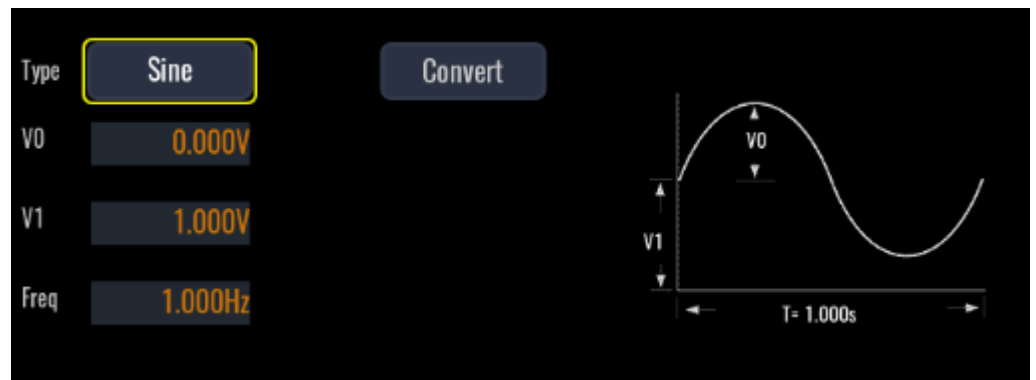

Parameter	Description
V0/ I0	The amplitude or peak value.
V1/ I1	The offset from zero. For power modules that do not generate negative values, the offset must be \geq Amplitude.
Freq	The frequency of the sine wave. The range from 0.00001 to 10000Hz.

5.2.7 Configuring Pulse Arb

1. Press the **[Function]** icon on the menu to enter the advanced function selection interface, and click the Arb function icon to enter the arbitrary waveform configuration interface.
2. Select the Priority attribute.
3. Click the button corresponding to Type, select Arb type in the pop-up box to Pulse.

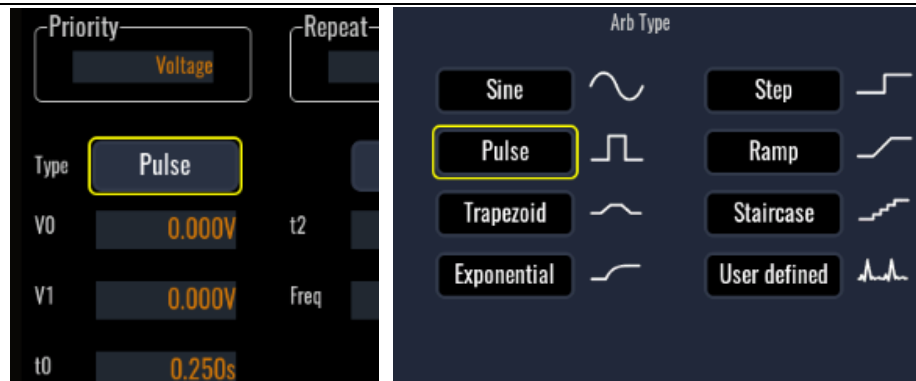

4. Configure the Pulse Properties.



Parameter	Description
V0/ I0	The setting before and after the pulse.
V1/ I1	The amplitude of the pulse.
t0	The delay after the trigger is received but before the pulse starts.
t1	The width of the pulse.
t2	The time the output remains at the end setting after the pulse completes.
Freq	Enter a frequency value directly. this will change the (T0), (T1), (T2) parameters, The range from 0.00001 to 10000Hz.

5.2.8 Configuring Trapezoid Arb

1. Press the [Function] icon on the menu to enter the advanced function selection interface, and click the Arb function icon to enter the arbitrary waveform configuration interface.
2. Select the Priority attribute.
3. Click the button corresponding to Type, select Arb type in the pop-up box to Trapezoid.

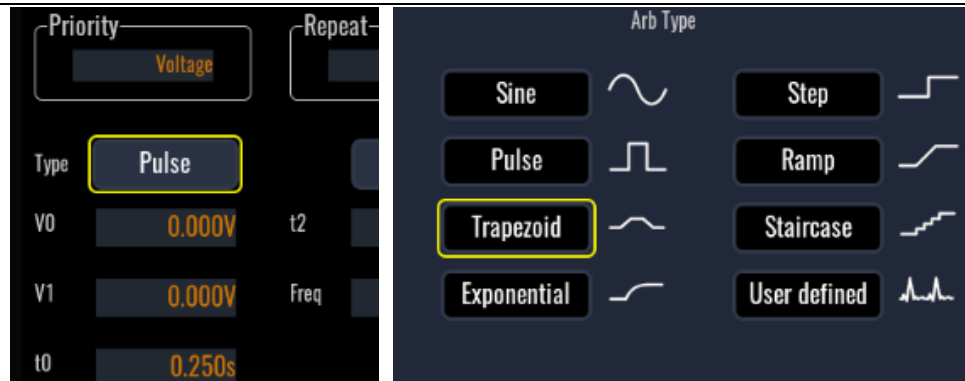

4. Configure the Trapezoid Properties.

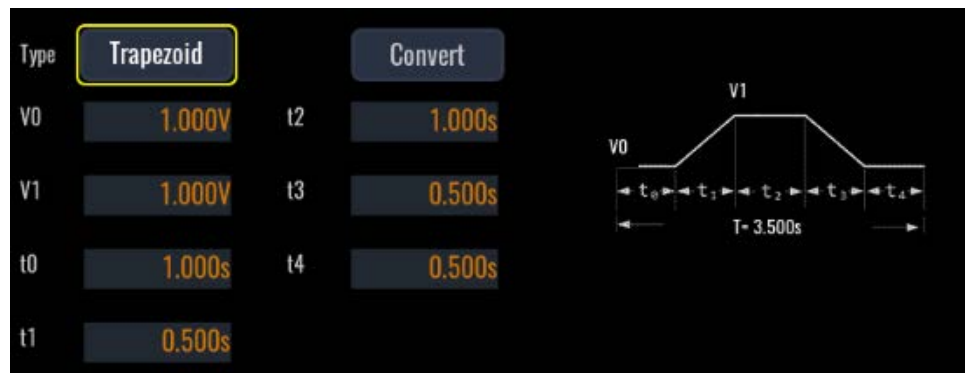

Parameter	Description
V0/ I0	The setting before and after the trapezoid.
V1/ I1	The peak setting.
t0	The delay after the trigger is received but before the trapezoid starts.
t1	The time that the trapezoid ramps up.
t2	The width of the peak.
t3	The time that the trapezoid ramps down.
t4	The time the output remains at the end setting after the trapezoid completes.

5.2.9 Configuring Exponential Arbs

1. Press the [Function] icon on the menu to enter the advanced function selection interface, and click the Arb function icon to enter the arbitrary waveform configuration interface.
2. Select the Priority attribute.
3. Click the button corresponding to Type, select Arb type in the pop-up box to Exponential.

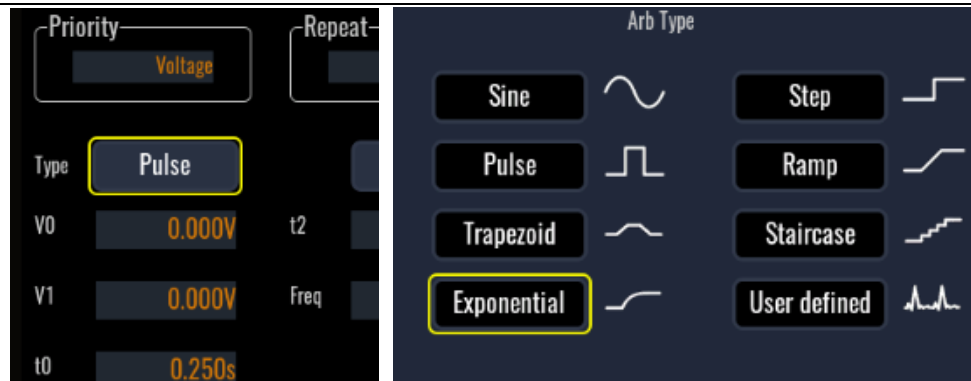

4. Configure the Exponential Properties.

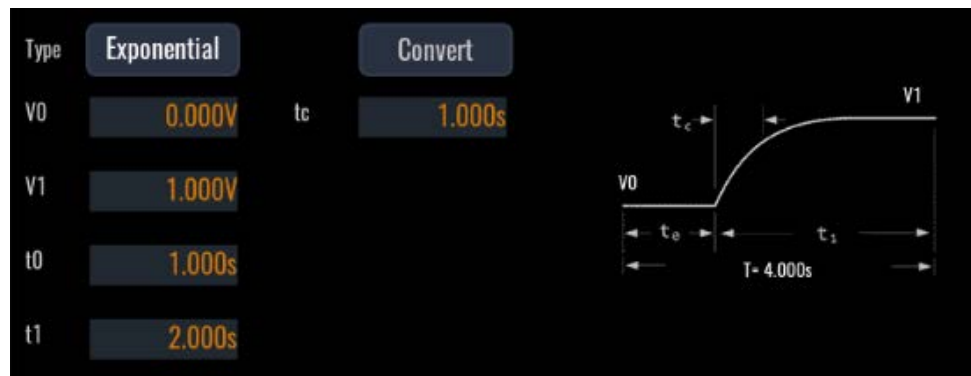

Parameter	Description
V0/ I0	The setting before the waveform.
V1/ I1	The end setting of the waveform.
t0	The delay after the trigger is received but before the waveform starts.
t1	Time for the amplitude to go from the start setting to the end setting.
tc	The time constant of the curve.

5.2.10 Configuring User-Defined Arbs

User-defined Arb waveforms can be used to edit waveforms via Demo software or imported via USB storage devices. Panel operation does not support editing.

1. Press the [**Function**] icon on the menu to enter the advanced function selection interface, and click the Arb function icon to enter the arbitrary waveform configuration interface.
2. Select the Priority attribute.
3. Click the button corresponding to Type, select Arb type in the pop-up box to User defined.

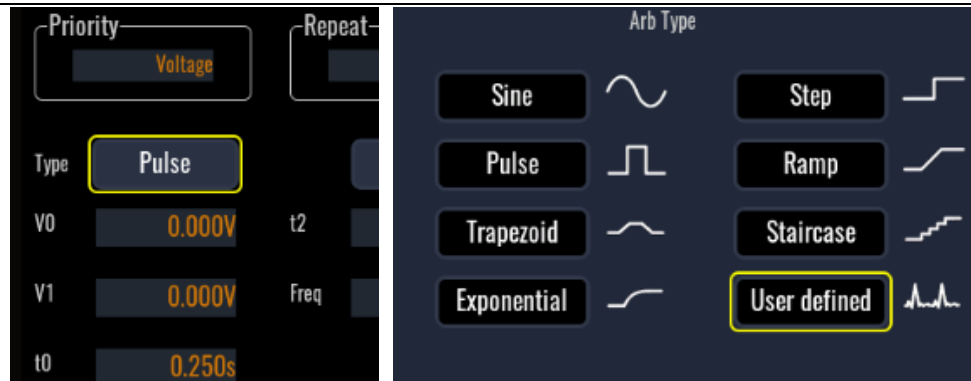

The user can also use the configured "standard" Arb to convert directly to a customized waveform by populating the user-defined Arb with the values from the standard waveform, and then editing those values in the User-defined window.

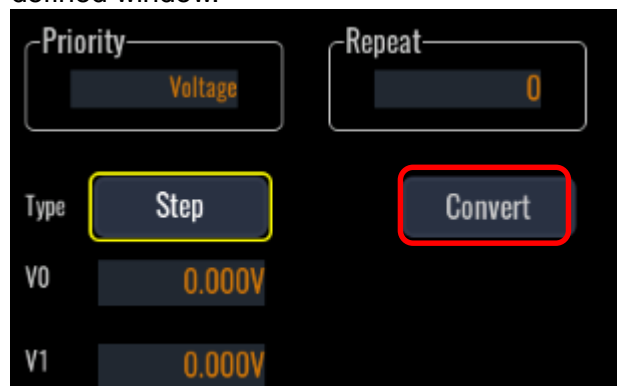

Convert: Convert the selected waveform type into a customized waveform. Convenient for users to modify waveform parameters directly based on the present waveform.

- Edit a custom waveform by clicking Voltage and Time in the list on the left. The edited waveform shape is displayed on the right side of the window.

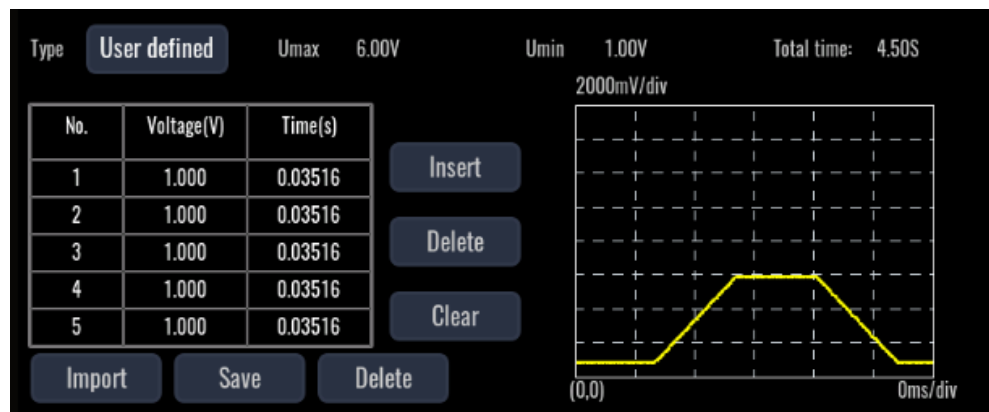

Parameter	Description
Insert	Insert a piece of data
Delete	Delete current data
Clear	Clear all data
Import	Importing waveform data
Save	Save the current customized waveform in the machine

or in a USB flash drive. When saved in a USB flash drive, it is saved in the form of a CSV format file, which supports secondary import.

Delete	Deleting custom waveform files
--------	--------------------------------

5.3 Configuring an Arb Sequence (ARB Sequence)

The Arb Sequence allows multiple and different Arbs to run one after another in succession. Any of the standard Arb types, except for constant-dwell Arbs, can be included in the Arb sequence. All Arbs in the sequence must be of the same type; either voltage, current, resistance, or power.

As with single Arbs, each Arb in the sequence has its own repeat count, can be set for dwell or trigger pacing, and can be set to repeat continuously. Note also that a repeat count can be set for the entire sequence, and it can also be set to repeat continuously.

The following figure illustrates a sequence comprised of a step Arb, a sine Arb, and a pulse Arb. The repeat count value indicates how many times each Arb repeats before moving to the next type.

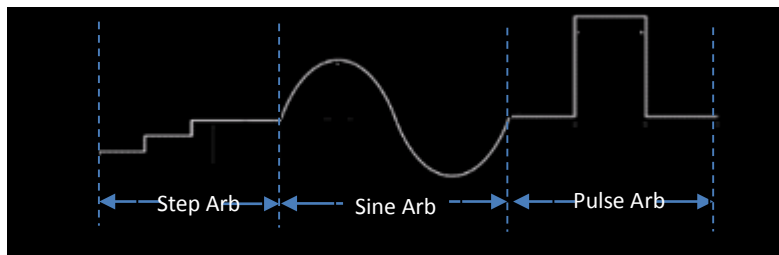

1. Press the **[Function]** icon on the menu to enter the advanced function selection interface, and click the Sequence function icon to enter the Sequence waveform configuration interface.



In this interface, the user can select the trigger method for sequence file

execution, and then click **[Run]** to output according to the waveform sequence parameters displayed in the window.

Parameter	Description
Trig source	The trigger source for list file running can be set to Immediate, Manual, Bus, PIN1~PIN7.
Repeat	The number of times the file loops
Step	The running step number of sequency
Run	Running the sequency file.
Open	Open the sequency file.
New	Create a new sequency file.
Edit	Edit the sequency file.
Delete	Delete the sequency file.

2. Press the New button to create a new arbitrary waveform sequence.



Parameter	Discription
Priority	Select the voltage/current/power/resistance attribute of the Arb.
Repeat	The number of times the Arb file loops, 0 means infinite loops, the maximum number of loops is 65535.
End	The output state at the end of List file. It can be set to Normal, Last, Off. Normal: jumps to the output state in Fix mode, Last: keeps the last step parameter output, Off: closes the output.
Tout Position	Select whether the trigger signal is generated before or after the step.
Insert	Insert a step after the last step.
Delete	Delete the step.

Clear	Clear all step.
Edit	Edit the selected wave curve information.
Open	Open an existing Arb file.
New	Create a new Arb file.
Save	Save an existing Arb file.
Save as	Name and save the newly edited Arb file.
Apply	Commit the parameter to make the parameter effective immediately.
Delete	Delete the Arb file.
No.	Arb step number
Type	Arb type.
properties	Arb parameter value
Pacing	Method of step jumps to next step. Auto: when the time is out, jumps to next step Trig: receive a trigger signal, jumps to next step.
Repeat	Repeat number of Arb waveform
Trigout	Output a trigger signal after the step

3. Select the voltage or current attribute of the Arb.
4. Click Insert icon and insert one Arb waveform.
5. Click and select the waveform, then click Edit to enter the waveform edit interface.

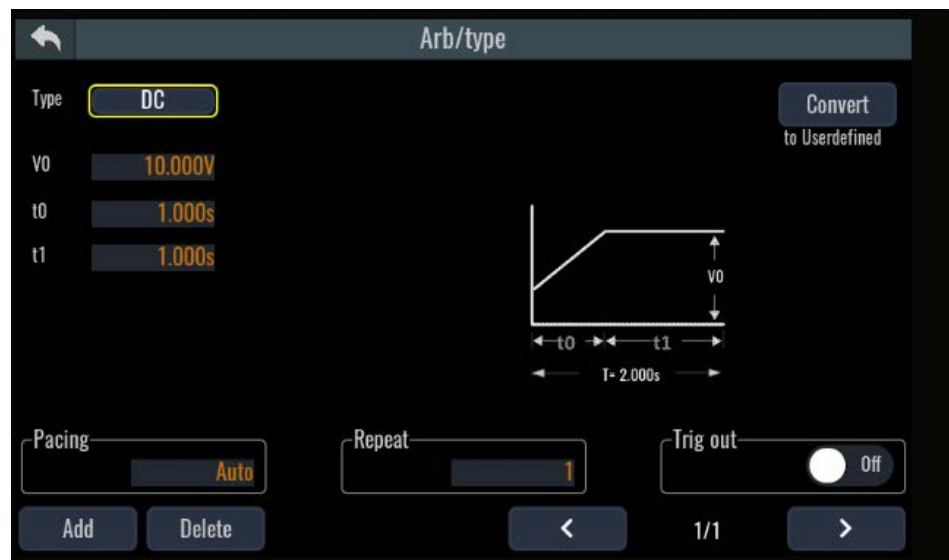

The meaning of Arb waveform parameters and how to edit them refer to chapter 5.2.

In this interface, you can click Add to add a new step, Delete to delete the current step, and click the forward and backward arrow keys to select the step to be edited. It is convenient for users to edit the whole sequence.

6. When you are finished editing, click Esc or  to return to the Sequence

File screen.

7. Press **[Save]** and save the sequence file.
8. Press **[Esc]** to return the Arb Sequence run interface.
9. Press **[On/Off]** enable the output, and click the Run icon.

It displays the step and the Arb Sequence run indicator. Pressing the Meter key displays the output data.

5.4 Configuring Constant-Dwell Arb

The CDARB constant dwell waveforms are different from other Arb in that they do not have separate dwell values for each point, and the dwell time is set uniformly, and a single dwell value applies to all points. And the minimum dwell time of CD Arb is 0.000005s.

Since CD Arb has many data points, users can edit waveforms by Demo software or web control, front panel operation does not support editing waveforms, only importing csv files.

1. Press the **[Function]** icon on the menu to enter the advanced function selection interface, and click the CDARB function icon to enter the Constant-Dwell Arb waveform configuration interface. Then press the **[Edit]** button on the interface to enter the main interface for editing the constant dwell wave.



This screen sets the voltage and current attributes, the number of repetitions, the running status at the end, and the residence time maintained by a single step.

Parameter	Description
Priority	Select the voltage/current/power/resistance attribute of the CDWell waveform, when different output attributes are selected, the waveform definition parameters are different.
Repeat	The number of times the file has been looped, 0 means infinite loops, and the maximum number of loops is 65535.

End	The output state at the end of List file. It can be set to Normal, Last, Off. Normal: jumps to the output state in Fix mode, Last: keeps the last step parameter output, Off: closes the output.
Interpolation	When linear interpolation is enabled, the system automatically performs linear interpolation calculations between discrete data points to generate continuous transition values. The slope between two adjacent points is determined based on the single-step residence time. When linear interpolation is disabled, the system skips the interpolation process and directly outputs the original discrete data points. The slope between two points is determined slope setting.
Dwell Steps	per The width of time that each data point resides. Range from 0.000005s to 10000s.

- Click the **[Import]** button and select Import Waveform Data.

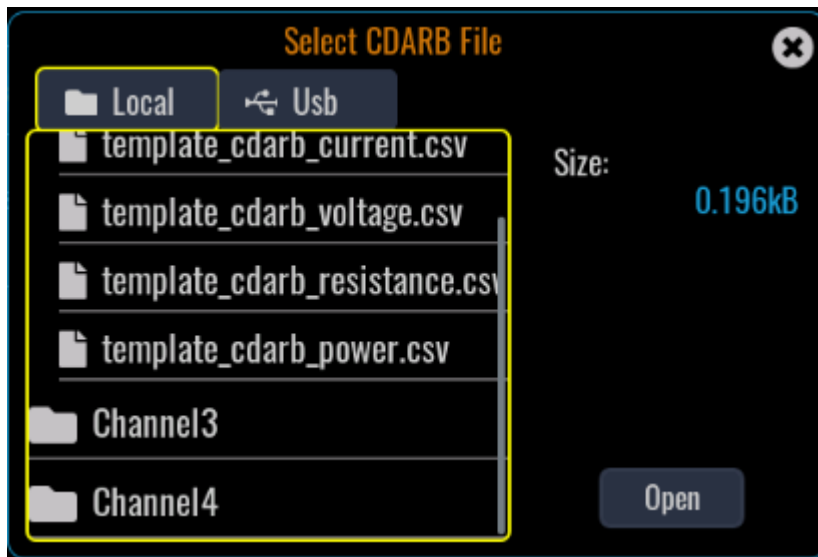

5.5 Sine Sweep Waveform

The sine sweep function allows you to set the start voltage value, end voltage value, start DC, start frequency, end frequency, and other parameters to depict a sinusoidal scan waveform.

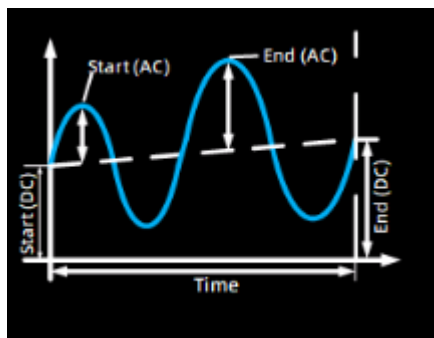

Operation Step

- Press the **[Function]** icon on the menu to enter the advanced function selection interface, and click the Sine Sweep function icon to enter the Sine

sweep waveform configuration interface.

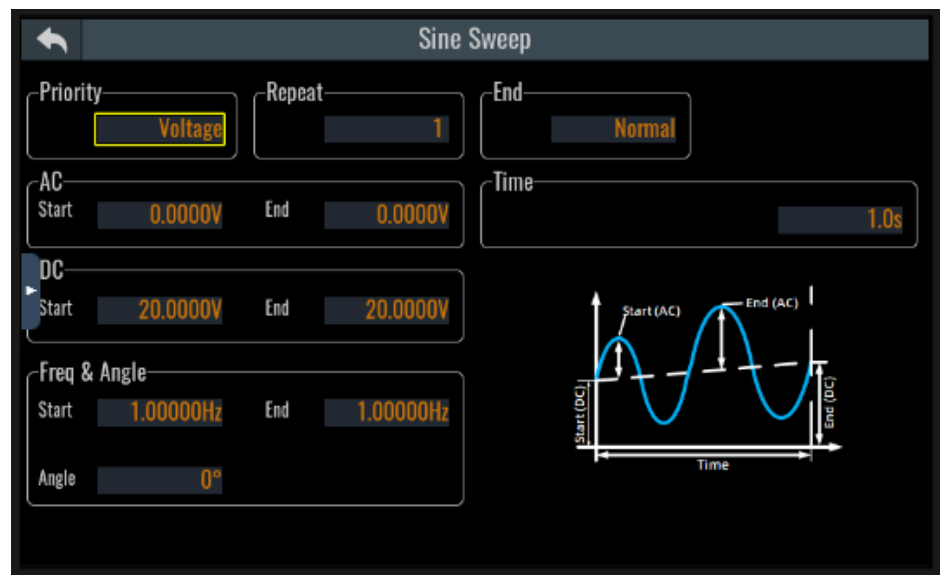

- Complete the setting of voltage and frequency related parameter values.

Parameter	Description
Priority	Select the voltage/current/power/resistance attribute of the sine waveform, when different output attributes are selected, the waveform definition parameters are different.
Repeat	The number of times the file has been looped, 0 means infinite loops, and the maximum number of loops is 65535.
End	The output state at the end of List file. It can be set to Normal, Last, Off. Normal: jumps to the output state in Fix mode, Last: keeps the last step parameter output, Off: closes the output.
AC Start/End	Start/Stop AC Amplitude
DC Start/End	Start/Stop DC offset
Freq Start/End	Start/Stop frequency, The range from 0.00001 to 10000Hz.
Angle	The waveform start angle.
Time	Total waveform duration.

- Return and press the [On/Off] key at the front panel to turn on the power output.
- Click the [Run] key to start running the sine scan waveform. The interface shows the running status.

5.6 Battery Simulation Function

This series power system can simulate battery characteristics in practical applications based on its unique bidirectional properties and the variable output impedance. You can set battery-related parameters to simulate the charge and discharge characteristics of the battery to assist with other tests.

1. Press the **[Function]** icon on the menu to enter the advanced function selection interface, and click the Battery Simulation icon to enter the configuration interface.



Parameter	Description
Set SOC	Sets the current pack SOC state.
Open	Open or select a battery simulation file.
New	Create a battery simulation file.
Edit	the battery simulation file.
Delete	Delete the battery simulation file.
Run	Running the battery simulation test
ESR	equivalent series resistance
Full voltage	Simulates the voltage value when the cell battery is fully charged.
Empty voltage	Simulates the voltage value when the cell battery is in the empty state.
+Curr	Positive current limit value
-Curr	Negative current limit value
Capacity	Simulates the capacity of a cell battery.

2. Click **[New]** or **[Edit]** to create a new battery simulation file or edit the current battery simulation file. The interface is shown below.

←
Battery simulation
CH1
→

Current Limits

+Curr -Curr

End Type

SOC Limits

Upper Lower

Layout

Series Parallel

Single Cell Properties

Mode Full Voltage Empty Voltage

Capacity Internal Res

Initial parameter

Initial Soc Initial Voc Initial Cap

untitled_01.csv
Open
New
Save
Save as
Delete

Parameter	Description
Current Limits	+Curr: Positive current limit value -Curr: Negative current limit value
SOC Limits	Upper: SOC upper limit Lower: SOC upper limit
End Type	The output state at the end of List file. It can be set to Normal, Last, Off. Normal: jumps to the output state in Fix mode, Last: keeps the last step parameter output, Off: closes the output.
Layout	Series: Number of batteries in series Parallel: Number of batteries in parallel
Single cell properties	Parameter settings related to single cell batteries.
	Mode: Battery type, you can choose the Basic or custom Curve.
	Capacity: Simulates the capacity of a cell battery.
	Initial para: Initial battery parameter selection: Initial soc/Initial CAP/Initial VOC
	Sets the initial state of charge of the battery. Check the box before setting the SOC value.
	Full Voltage: full voltage of battery
	Empty Voltage: empty voltage of battery.
	Internal Resistance: internal resistance of battery
Initial parameter	Battery initial state parameter selection.
	Initial Soc: Select the runtime based on the initial charge and fill in the initial charge status value.

	Initial Voc: Select the runtime based on the initial voltage and enter the initial voltage value.
	Initial Cap: Select the runtime based on the initial capacity and fill in the initial capacity value.
Open	Open or select a battery simulation file.
New	Create a battery simulation file.
Save	Save an existing battery simulation file.
Save as	Name and save the newly edited battery simulation file.
Delete	Delete the battery simulation file

3. Press **[Save]** to save.
4. Return and press the **[On/Off]** key to turn on the power output.

Click the **[Run]** key to start running the battery simulation test. The interface shows the running status.

5.7 Battery Charging Test Function

This series of power systems supports the battery charging function. Users edit the test file in the interface and call the battery test file to execute the test as needed.

Precautions

Please confirm that you have understood the general safety precautions before connection. Please pay special attention to the following safety precautions when connecting the battery.

WARNING

- When connecting the DUT (battery/capacitor), do not short-circuit the battery.
- It is recommended that for battery testing, a fuse must be connected in series between the power supply and the battery to prevent short circuits caused by any problems.
- Be careful not to reverse the battery/capacitor connection, reverse connection will cause damage to the instrument, even if it is not powered on.
- To avoid battery short circuit, be sure to check that the test line end is not connected when connecting or disassembling the test line. When the test line end is connected with battery, short circuit may cause severe accident.
- To avoid the damage of the instrument, please make sure the positive and negative electrodes of the electrode when connecting the battery and other energy storage equipment.
- Hazardous voltages may still be present on the positive and negative electrodes after the unit is turned off; never touch the cables or electrodes immediately. Make sure that no dangerous voltage is present on the electrodes or sense terminals before they are touched.

1. Press the **[Function]** icon on the menu to enter the advanced function selection interface, and click the Battery Charge icon to enter the configuration interface.



The left side displays the battery charge file parameters, refer to the parameter introduction in the battery charge file editing function for details.

Parameter	Description
Open	Open or select a battery charge test file.
New	Create a battery charge test file.
Edit	Edit the battery charge test file.
Delete	Save as the battery charge test file.
Run	Run the test

2. Click **[New]** or **[Edit]** to create a new battery charge file or edit the current battery charge file. The interface is shown below.

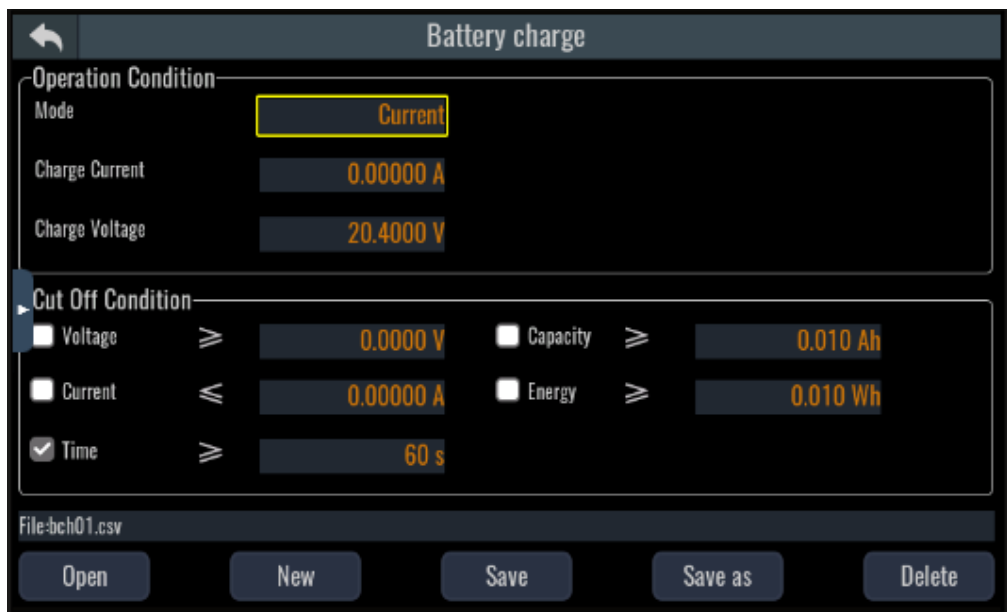

Parameter	Description
Mode	Select the charge mode for battery charge.

Charge Current	Set the current value for charging
Charge Voltage	Set the voltage value for charging
Cut Off Condition	Battery charge test cut off condition
	Voltage: Charging ends when the voltage is greater than or equal to this setting.
	Current: Charging ends when the current is less than or equal to this setting.
	Time: Charging ends when the time is greater than or equal to this setting.
	Capacity: Charging ends when the capacity is greater than or equal to this setting.
	Energy: Charging ends when the energy is greater than or equal to this setting.
Open	Open or select a battery charge test file.
New	Create a battery charge test file.
Save	Save the battery charge test file.
Save as	Save as the battery charge test file.
Delete	Delete the battery charge test file.

3. Press **[Save]** save the file.
4. Return and press the **[On/Off]** key at the front panel to turn on the power output.
5. Click the **[Run]** key to start running the waveform. The interface shows the running status.

5.8 Battery Discharging Test Function

This series of power system supports battery discharge function in bidirectional source mode or load mode. Users edit the test file in the interface and call the battery test file to execute the test as needed.

Precautions

Please confirm that you have understood the general safety precautions before connection. Please pay special attention to the following safety precautions when connecting the battery.

WARNING

- When connecting the DUT (battery/capacitor), do not short-circuit the battery.
- To avoid battery short circuit, be sure to check that the test line end is not connected when connecting or disassembling the test line. When the test line end is connected with battery, short circuit may cause severe accident.

- To avoid the damage of the instrument, please make sure the positive and negative electrodes of the electrode when connecting the battery and other energy storage equipment.
- Hazardous voltages may still be present on the positive and negative electrodes after the unit is turned off; never touch the cables or electrodes immediately. Make sure that no dangerous voltage is present on the electrodes or sense terminals before they are touched.

1. Press the **[Function]** icon on the menu to enter the advanced function selection interface, and click the Battery Discharge icon to enter the configuration interface.



The left side displays the battery discharge file setting parameters, refer to the parameter introduction in the battery discharge file editing function for details.

Parameter	Description
Open	Open or select a battery charge test file.
New	Create a battery charge test file.
Edit	Edit the battery charge test file.
Delete	Save as the battery charge test file.
Run	Run the test

2. Click **[New]** or **[Edit]** to create a new battery discharge file or edit the current battery discharge file. The interface is shown below.

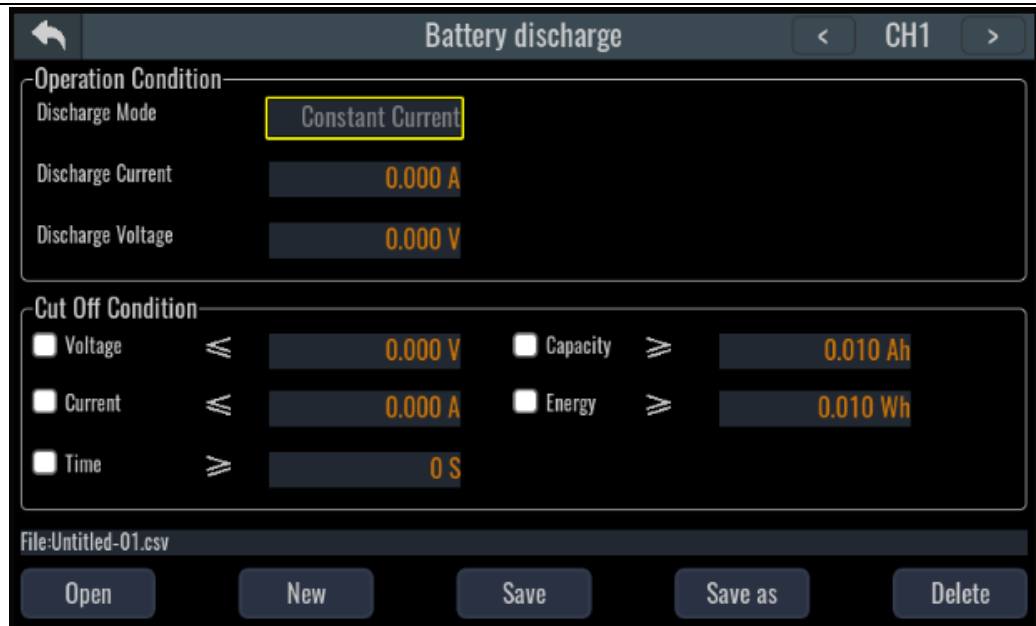

Parameter	Description
Discharge Mode	Set the discharge mode for Discharging
Discharge Current	Set the current value for Discharging
Discharge Voltage	Set the voltage value for Discharging
Cut Off Condition	Battery charge test cut off condition
	Voltage: Discharging ends when the voltage is less than or equal to this setting.
	Current: Discharging ends when the current is less than or equal to this setting.
	Time: Charging ends when the time is greater than or equal to this setting.
	Capacity: Charging ends when the capacity is greater than or equal to this setting.
	Energy: Charging ends when the energy is greater than or equal to this setting.
Open	Open or select a battery charge test file.
New	Create a battery charge test file.
Save	Save the battery charge test file.
Save as	Save as the battery charge test file.
Delete	Delete the battery charge test file.

- Press [**Save**] save the file.
- Return and press the [**On/Off**] key at the front panel to turn on the power output.
- Click the [**Run**] key to start running the waveform. The interface shows the

running status.

5.9 Dynamic Functions (Load module support)

Through dynamic test operation, the electronic load can be switched between two setting parameters based on setting rules. This function can be used to test dynamic performances of power supply.

The dynamic test mode can be divided into continuous mode, pulse mode and toggle mode.

Continuous mode

Under continuous mode, after enabling dynamic test operation, the load will be switched continuously between I0 value and I1 value. The following picture shows the current waveform in continuous transient operation.

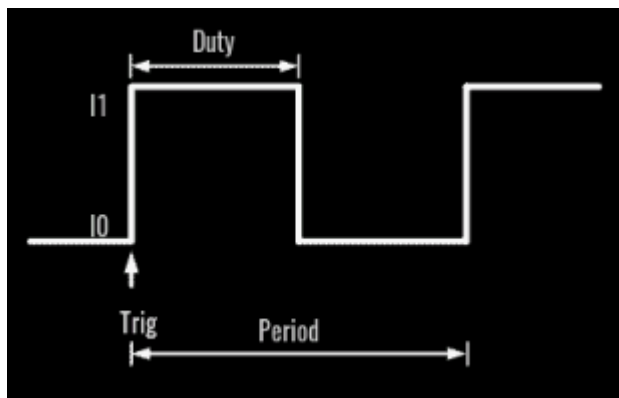

Pulse mode

Under pulse mode, after enabling dynamic test operation, the load will switch to I1 value after receiving of a trigger signal. Then the load will switch back to I0 value and be constant at I0 value after maintaining I1 for pulse width time. The following picture shows the current waveform in pulse transient operation.

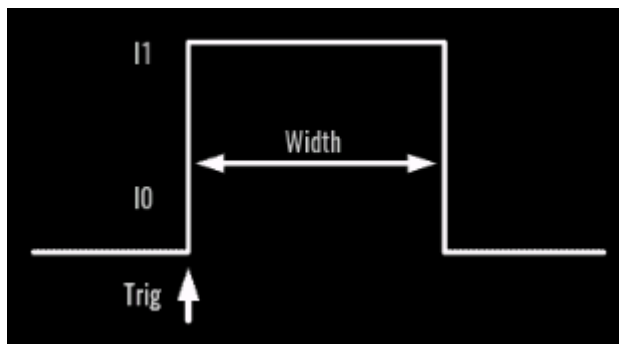

Toggle mode

Under toggle mode with dynamic test function enabled, the load switches between I0 value and I1 value upon receiving a trigger signal, as shown in the following figure. The following picture shows the current waveform in toggle transient operation.

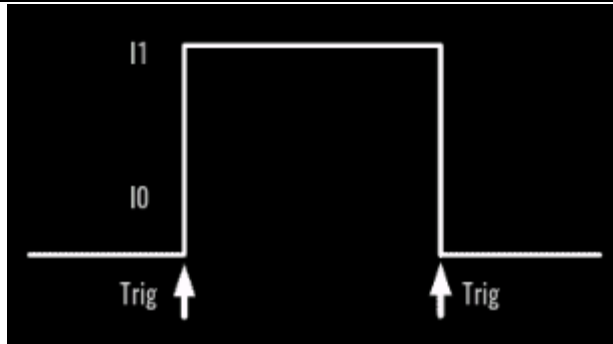

Operation Step

1. Press the **[Function]** key on the front panel to enter the advanced function selection interface, and click the **Transient** function icon to enter the dynamic function configuration interface. Then press the **Edit** button in the interface to edit.

Take continuous mode as an example to introduce the operation procedure, please refer to the actual display for other modes:

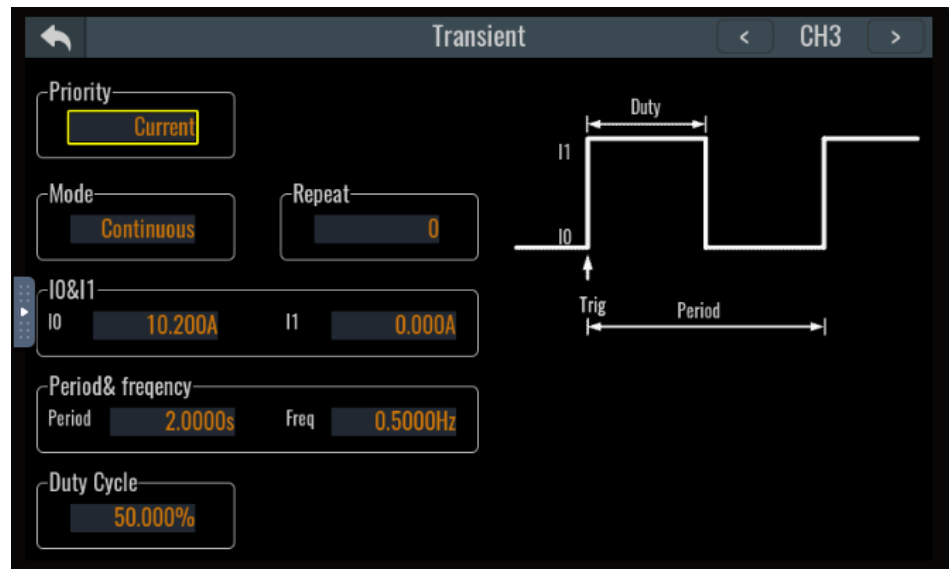

2. In the edit screen, complete the setting of the relevant parameter values.

Parameter	Description
Priority	Select dynamic attributes,voltage/current/power /resistance
Mode	Dynamic mode
Repeat	The number of times the dynamic test file loops, 0 represents infinite loops, and the maximum number of loops is 65535.
I0/I1	Two state values that are dynamically switched. Depending on the Priority, the value attributes are set differently. Take CC mode as an example, set two current values.
Period&frequency	Set the period or frequency to set the period duration of the waveform.

Duty Cycle	The waveform duty cycle, which controls the length of time the I1 state is maintained.
------------	--

3. Press the [**On/Off**] key at the front panel to turn on the instrument output.
4. Click the [**Run**] key to start running the dynamic waveform. The interface shows the running status.

Chapter6 Using the Measurement Function

This series power system has a powerful measurement function, a variety of measurement modes to meet the user's various needs, the measurement function includes: Meter function, oscilloscope function

6.1 Meter Function

Each output has its own measurement capability. When the Meter view is displayed, the measurement system continuously measures the output voltage and current.

The measurement system acquires as many points as needed based on the number of power line cycles (NPLC) and the time interval, and averages the samples.

As shown below, The single-output view, the four output view and 8 output view.



Press the Meter and View key to toggle between the views.

- Single-output view



In this view, the user can select the channel number displayed in the main screen by clicking on the channel number. The main screen can display the current output setting status of the instrument, slope status, power limit, protection setting and output voltage and current power measurement information.

Only the output status and voltage and current measurements are displayed in the other small screens.

- Four output view



In this view, the default four channels CH1, CH2, CH3 and CH4 are shown in large display. The user can click the channel number to select the channel displayed in the main screen. The main screen can display the current output setting status of the instrument and the output voltage, current and power measurement information.

Only the output status and voltage and current measurements are displayed in the other small screens.

- Eight output view



This view displays the output setting status, the output voltage and power measurement information of the eight channels.

6.2 Instrument measurement settings

Measurement parameters can be configured for all power/load modules, including sampling mode selection, measurement parameter adjustment, and more.

6.2.1 Remote Measurement Function

The IT2705 series instruments support both local and remote measurements, of which remote measurements are suitable for scenarios that require high measurement accuracy (see the IT2705 user manual for more information).

The procedures to set the menu item are as follows.

1. Press the **[Config]** keys to enter the configuration menu.
2. Press the up/down key or rotate the knob to select **Source** and press **[Enter]**.
3. Select **Remote Sense** and set the status.
 - Off: Default value, indicates turn the sense function off.
 - On: Indicates turn the sense function on.

After the parameter settings are complete, press **[Enter]**.

6.2.2 Setting sampling mode

Select the Measure tab in the Config menu to set the parameters related to the measurement.

- NPLC: Number Power Line Cycles
- Aperture: Sampling frequency mode selection.
- Time Interval: Time sampling mode
- Line frequency: AC power supply frequency
- Points: Sampling points

6.2.3 Whour & Ahour measurement

The instrument can measure the energy parameter ampere-hour and watt-hour data. In the Config menu you can choose whether or not to auto zero before output.

6.2.4 Select measurement range (SMU module support)

The SMU module supports voltage and current range settings, with different ranges offering more suitable resolution and measurement accuracy.

- After selecting the priority in the Config menu, set the range for voltage or current. When setting, the voltage and current values are controlled by the range.
- In the Config menu, select the Measurement tab. Select the current measurement range. Users can select the current measurement range. Different ranges have different current measurement resolutions and accuracies.

6.3 Scope Function

The power system's scope function is similar to a bench oscilloscope, displaying output voltage and current signals as a function of time. It has controls that select which outputs and functions to display, front panel knobs that adjust gain and offset, and configurable triggers and markers.

You can configure the Scope View to display voltage or current waveforms for all outputs. As explained under Horizontal Properties, the maximum sampling rate of the scope varies, depending on the number of waveforms that are displayed. Note that in the Scope View there is only one time-base and trigger configuration for all outputs.



6.4 Data logging function

The Data Logger is similar to the Scope View function, you can configure the Data Logger View to display voltage or current waveforms for all outputs. The display functions like a strip chart recorder. Use the Waveform Display knobs to scroll through the data. Unless specified otherwise, data is automatically stored to a file named *default.dlog*.

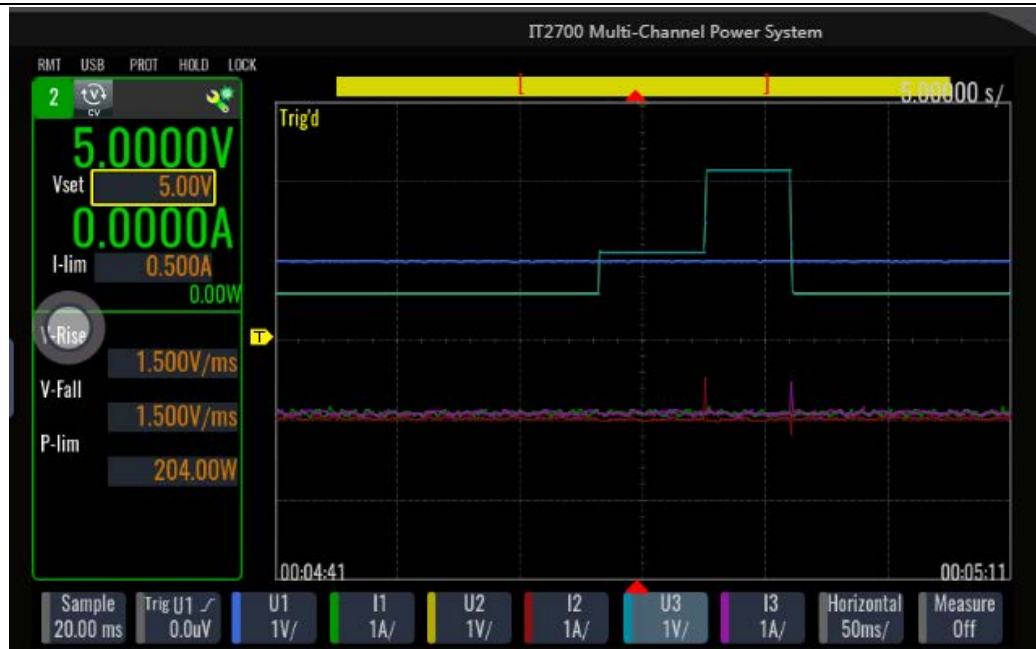

Configure the data logger properties:

Press the **Sample** key to configure the data logger properties.



Parameter	Description
Run/Stop	Start/stop sampling data.
Default	Restores the initial value setting.
Duration	Sampling duration
Sample Period	Sample Period
Log Min/Max	Whether to sample the maximum and minimum values.
Signal source	Data source
Continuous	Check this box to enable the task to run on a recurring

	schedule.
Store Area	The storage location to be saved can be either local or USB drive.
File Type	You can select the format of the saved data file. Csv and Tdms can be selected
File Name	Setting the name of the saved data file
Export to Udisk	Export to a USB flash drive.

6.5 Electrochemical Impedance Spectroscopy (SMU module support)

Electrochemical Impedance Spectroscopy (EIS) is a technique used to investigate the characteristics of electrochemical systems by applying a small-amplitude AC perturbation and measuring the system response. It supports impedance spectroscopy analysis of samples such as batteries, corrosion systems, sensors, and supercapacitors, providing complex impedance data in the frequency domain for evaluating electrode interface properties, reaction kinetics, and material performance.

When configured with the Source Measure Unit (SMU) module, the IT2705 supports Electrochemical Impedance Spectroscopy (EIS) testing.





Note

After switching to the EIS function, the instrument will automatically switch to sense remote measurement mode. Before performing the test, please ensure that the sense measurement lead is connected; otherwise, the instrument will trigger a sense protection error.

1. Press the **[Function]** key on the front panel to enter the Advanced Function Selection interface. Tap the **EIS** icon to access the main interface of the **EIS** function. The display style varies depending on the selected display mode; the following description uses the default interface as an example.



Parameter	Description
Normal	Select data analysis mode, include Numeric, Bode Plots, Nyquist, Table.
Start	Start to EIS test.
Edit	Edit the mode and parameters of EIS.
	Impedance value
	Angle value
AC	Display AC voltage, AC current, and frequency values
DC	Display DC voltage, DC current

- Click [**Edit**] to enter the EIS Function Edit interface. In this interface, you can configure source-related parameters for EIS, set chart display parameters, and perform pre-measurement zeroing operations. All parameters and zeroing results can be saved into a file for convenient recall in subsequent tests.



Parameter	Description	
DC/AC	Mode	Select the signal setting mode. Sweep: Scan based on step values Fixed: Output fixed at the set value
	Edit	The mode selection is displayed only during scanning. Edit the point list data for DC/AC.
	DC	Offset of waveform
	AC	Amplitude of waveform
Frequency	Mode	Signal Frequency Value Setting Mode

	Sweep: Scan based on step values
	Fixed: Output fixed at the set value
Sweep Type	When the frequency mode is set to scan, select the type of frequency scan: linear, logarithmic, or list.
Start Freq	When the frequency mode is set to scan, the starting frequency of the scan is displayed, with a range of 0.01 Hz to 20000 Hz.
Stop Freq	When the frequency mode is set to scan, the stop frequency of the scan is displayed, with a range of 0.01 Hz to 20000 Hz.
Step Freq	Scanning single-step frequency.
Step count	The number of steps scanned and the step frequency influence each other.
Convert	Convert the current linear or logarithmic data into a list format and perform editing within the list. In this mode, linear or logarithmic data is directly switched to the list mode.



Description	Description
Cursors	When selecting a Bode plot or Nyquist plot, the interface displays the M1 and M2 cursors.
Bode Display Item	Plits The impedance parameters displayed on the interface when selecting a Bode plot or Nyquist plot.

- Press the **[Return]** key to go back to the main interface.

4. Press the **[Start]** key to execute the measurement. Before starting, you can perform a zeroing operation in the Edit interface to eliminate environmental background noise and improve measurement accuracy.

When performing this step, follow the on-screen instructions to short-circuit the sense lead and the output lead.

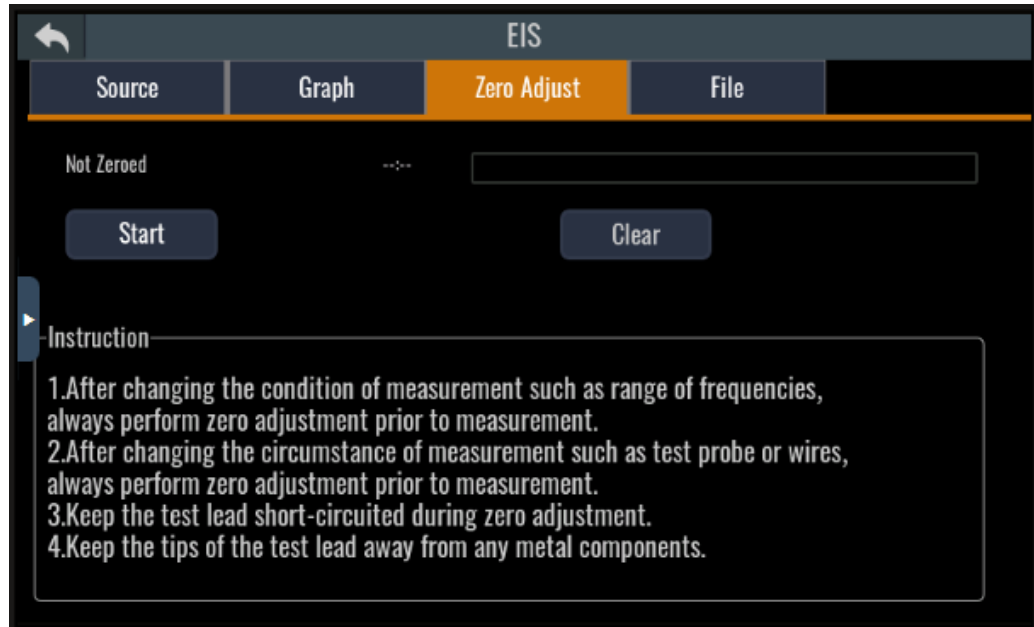

Chapter7 System-Related Functions

7.1 Setting System General Parameters

Select System -> General to setting system general parameters.

Set the Power-on State

This parameter determines the state of the instrument after power on.

1. Press the **General** under the system menu.
2. Turn the knob to select the **Power on settings**.
 - **Reset**: Default value, indicates when the instrument is powered on, the instrument will initialize some parameter settings or state, such as output voltage and output current.
 - **Last**: Indicates when powered on, the instrument will remain the same parameter settings and output status as last time you powered off the instrument.
 - **Last+Off**: Indicates when powered on, the instrument will remain the same settings as last time you powered off the instrument, but the output status is **Off**.

Restored to Factory Setting

This menu item is used to restore some parameter settings to factory setting values.

1. Select the **General** under system menu.
2. Click **Reset** under the **Factory default settings** menu item. The interface will prompt you to select the parameters that need to be restored to factory defaults. Select them and click [**Reset**] to confirm. The instrument will complete the factory default restoration operation and return to the main interface.

Setting Current Display Symbol for Load

This option is used to set the symbol of the load current display. Selecting **Positive+**, the load current displays positive current value. Selecting **Negative-**, the load current displays a negative current value.

Set Slope Type for Source mode

This option is used to set the type of power supply slope setting. Selecting **Rate** indicates that the set slope is a speed value. Selecting **Time** indicates that the set slope is a time value.

Output State After Protect Clear

This option is used to select the instrument output after the protection status is cleared.

Off: After protection clearance, the instrument output remains disabled.

Auto: After the protection is cleared, the instrument's output status automatically reverts to its state prior to the protection event. When users require automatic output shutdown and restoration during certain tests, select the "Auto" option.

System Reboot

This option is used to reboot the system.

7.2 Setting Instrument General Function

Select **System -> Preference** to setting instrument general parameters.

Set the keyboard sound

This item can set the key sound state.

- If **Key Click Buzzer** is set to ON mode, then when you press a button, the instrument will beep. If it is OFF mode, the beeper will not make a sound. The default set is in ON mode.
- If **Alarm Buzzer** is set to ON mode, the buzzer sounds when protection occurs; if it is OFF, the buzzer does not sound.

Set the screen brightness

This item can set the screen brightness. Set the screen brightness within the range 1 to 10 by pressing number keys on the front panel. The larger the number is, the higher the screen brightness is. You can also set the screen brightness by rotating the knob on the front panel.

Set the Soft Keyboard

The user can open the soft panel in the menu. When the parameter is set to ON, the soft keyboard is enabled. And when setting parameters on the screen, the soft keyboard appears. Convenient users directly touch screen to select the number.

Set the Knob Function

Set the **Knob immediately Effective** function. If set to ON, the Knob setting will take effect immediately. If set to OFF, press Enter to confirm the effect after the Knob setting is completed.

Default Meter View Settings

This menu item allows you to set the default display of the screen, for example, select Meter3 and the meter interface displays 3 channel screens after power on. The user can select Meter1, Meter3, Meter6 in the menu.

Select Language

Users can select the instrument language type from the menu.

Set Touch Screen

The user can turn off or turn on the touch screen function.

If set to on, the touch screen is effective, if set to off, the touch screen is invalid.

7.3 Setting Communication

This menu item is used to set the communication method between the instrument and the PC. IT2705 series instruments are equipped with USB and LAN interfaces as standard.

The user selects the used communication interface in the menu, and the user only needs to set the communication parameters and keep them consistent with the PC settings.

- To select the USB communication method, the USB type must be select to DEVICE.
- To select the LAN communication method, you need to configure the gateway address, IP address, mask address and socket port.

7.4 Screen Lock Function

Click **[Shift] + [6]** (Lock) on the front panel to lock the instrument screen. In the screen lock state, click any position of the screen, the interface will prompt "Do you really want to unlock it?". Users can choose ok to release the screen lock status.

7.5 Switching Local/Remote Mode

When the instrument is in RMT remote control mode, the user can switch the instrument from remote mode to local mode by clicking **[Shift] + [3]**(Local).

After the instrument is powered on, the default is the local operation mode. In local operation mode, the touch screen can be operated normally, and the screen is not available when the power is in remote operation mode.

Switching from local to remote operation mode can be controlled by command from PC. The change of operation mode does not affect the set parameters of the instrument.

7.6 Save and Recall Operations

The power system can save common parameters in nonvolatile memory for user to recall conveniently.

The saved parameters include:

- Power supply mode
- Present output mode
- Config menu settings

You can do the save and recall operations by the following two methods.

- In the menu interface, press the **[Shift]+[2]**(Save) button to save the parameters. Press the **Recall** to recall the parameters.
- SCPI commands: *SAV and *RCL

Saving the parameters

The save parameter operates as follows:

1. Press **[Shift]+[2]**(Save).
2. Select the save data location.
3. Press **[Enter]**.

When saving is completed, the interface will display the saved detailed parameters.

Recalling the Parameters

Recalling the data in the memory and used as the present setting value.

1. Press [**Recall**] to enter the recall parameter interface.
2. Select the recalling data location.
3. Press [**Enter**].

When recalling is completed, the interface will display the saved detailed parameters.

7.7 Screen Capture Function

IT2700 series power supply has the screen capture function. Insert the USB equipment into the USB interface of the front panel, and press [**Print**] to capture and save the screen into the USB disk.

When you need the screen capture function, the USB type under the system menu needs to be set to **Host**.

7.8 Query the System Log

The IT2700 series power system provides the system operation Log query function. Click shift+5[Log] to enter the Log query interface. You can view historical system operation records on this screen.

7.9 Query the System Information

Users can click[**Shift**] + [4] (Info) to enter the system information interface to view all channel information, including channel module name, SN number, specifications, and firmware program version.

When the instrument requires maintenance, the user needs to check this information for confirmation.

7.10 System Management Functions

IT2705 series power system supports system management function, click Admin function in Menu to enter the system management interface and log in, in this interface you can clean up the data and change the system password.

The default password is 2705 when the instrument is shipped from the factory.

Login/Logout

Access the information and landing pages of the system administration interface.

Calibration

View the calibration records.

Sanitize

Erase system logs and information, including all functional data and files.

Firmware update

Upgrade the firmware program in the machine UI interface. This series of instruments provides three update methods. The UI update method is performed in this interface, and in addition, it can be updated via boot update or Web update.

Firmware Sync

View the firmware version of module.

7.11 Digital I/O Function

This series power system supports digital I/O function. The user can realize logic control over high and low level input or output by related configurations in the system menu.

Pins Introduction

Different I/O implements different functions. The detailed functions description are shown in the figure below:

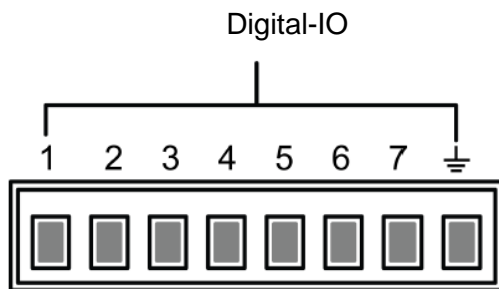

Pin	Type	Description	Properties
Digital IO-1	Input/Output	Remote Inhibit, Turn off the output under emergency status	Level signal
Digital IO-2	Input/Output	PS, Protection state indicator	Level signal
Digital IO-3	Input/Output	PS Clear, Clear the protection state	Pulse signal
Digital IO-4	Input/Output	OnOff Status, OnOff-status indicator	Level signal
Digital IO-5	Input/Output	Sync, synchronous control	Pulse signal
Digital IO-6	Input/Output	On Couple, Turn on the output	Pulse signal
Digital IO-7	Input/Output	Off Couple, Turn off the output	Pulse signal
⏏		Ground terminal, that is, the negative terminal corresponding to each of the above 7 pins.	



General Digital I/O Function

- Signal definition

Digital I/O functions involve input and output levels and pulse signals. The input signal is the control signal provided externally to IT2703, the output signal is the level signal provided externally by IT2703, and the pulse signal is the edge signal switched between high and low levels.

Input signal	High level signal	Typical: 5V Range: 1.6V-15V Current: ≤100mA
	Low level signal	Typical: 0V Range: -5V-0.8V Current: ≤100mA
Output signal	High level signal	Voltage level: 5V Current: ≤1mA
	Low level signal	Voltage level: 0V Current: 0.5mA
Pulse	Level rise slope	10us
	Level fall slope	2us
	Width	Can be set from 5us to 500us

- Input/Output Function

The IO-1 ~ IO-7 pins are featured default function, the user can setting the function of pin according to requirement. The Input and Output are the general digital I/O function, and the parameter settings and functions of the seven pins are the same.

The IO-1~IO-7 pins provide default functions. Users can realize control according to the functions defined. Users can also reset the input or output properties of the present pin and customize the function use of the pin according to their needs.

When pins 1 to 7 are configured to Output function, when send the

command (IO:STATE 1/0) to instrument, the IO pin can output high level (False) or low level (True).

When pins 1 to 7 are configured to Input function, an external signal can be Input to this pin, and the instrument can detect the state of the external signal.

- Signal Revert

Select Invert or not under the IO Settings menu. If setting to OFF, it means the default level will be valid. If setting to ON, it means the valid signal is reversed. For example, the IO-1 pin is inhibit output by default and the high level is valid, when select revert ON, the low level is valid and the instrument output is disabled.

Digital IO-1

IO-1 pin can be set to **【Inhibit】** , **【Digital-In】** , **【Digital-Out】** , **【Trig-In】** , **【Trig-Out】**

The default function is inhibit output. When the IO pin is configured for a Inhibit function and the level signal is low, the output of the machine is forbidden. At this point, Pin 1 has a bi-directional I/O function, which can both receive the level signal input from the external instrument and output the level signal outward.default level is high, and low is valid when entering. Outgoing output also generates low level signals.

When the Inhibit Coupling function is enabled, the instrument's output recovery behavior is affected by the configuration of Inhibit Output Coupling in the system menu. Please check System > Coupling > Inhibit Coupling". The effects of different settings are as follows:

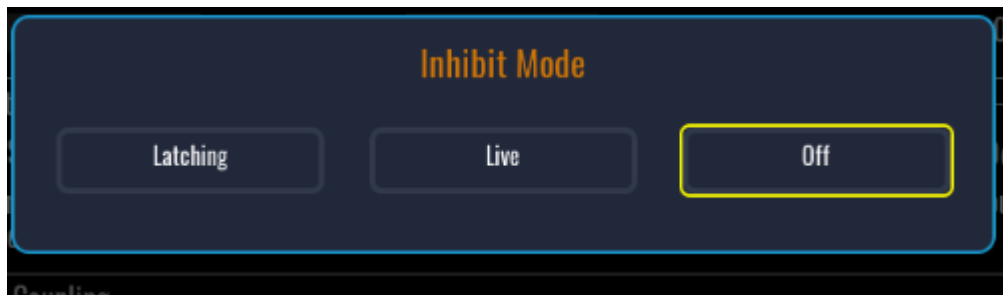

- Live:

When the control signal disables the output, the instrument output is turned off. The status bar on the screen displays the INH warning icon, and the output indicator shows "OFF".

If the instrument was previously in the ON state, the On/Off key remains lit after the output is disabled. Once the voltage level of IO-1 is released (from 0 to 1), the instrument output resumes normal operation.

This function is used to control the output switching of the instrument.

- Latching:

When the control signal disables the output, the instrument output is turned off. The On/Off key indicator goes out, the LCD displays an INH warning icon, and the output indicator shows "OFF".

To restore output, the control signal must be released and the warning must be manually cleared. Then press the On/Off key again to enable output.

Digital IO-2

IO-2 pin can be set to **【PS】**, **【Digital-In】**, **【Digital-Out】**, **【Trig-In】**, **【Trig-Out】**

The default function is protection state indicator. IO-2 pin will output high or low level based on whether the instrument is under protection or not. Under normal conditions (Not under protection), and when pin2 is under default setting (Not Invert), pin2 outputs high level; when the instrument is under protection, pin2 outputs low level. When pin2 is set to Invert, the output level is completely opposite.

Digital IO-3

IO-3 pin can be set to **【PS-clear】**, **【Digital-In】**, **【Digital-Out】**, **【Trig-In】**, **【Trig-Out】**

The default function is to clear the protected state. When the protection occurs, the protection state can be cleared through this pin, so that the instrument can continue to output normally.

IO-3 is bi-directional, that is, when the power supply is in a protected state, the instrument can receive a pulse signal from an external input through IO-3 for clean protection operation, or when the power supply is in a protected state, the clean protection can generate a pulse signal from IO-3.

Digital IO-4

IO-4 can be set to **【OnOff-status】**, **【Digital-In】**, **【Digital-Out】**, **【Trig-In】**, **【Trig-Out】**

The default function is to indicate the output state of the power supply, in case of output is ON, output 5V, otherwise, output 0V.

When pin4 is set to Invert, the output level is completely opposite.

Digital IO-5

IO-4 pin can be set to **【Sync-in】**, **【Sync-out】**, **【Digital-In】**, **【Digital-Out】**, **【Trig-In】**, **【Trig-Out】**

【Sync-in】 : Indicates configuration for synchronous input functionality, enabling machine synchronization with external sources. In this mode, the machine synchronizes with output information received through this I/O port.

【Sync-out】 : Indicates that the device is configured for synchronous output functionality, enabling it to provide synchronization signals to other machines.

Digital IO-6

IO-6 pin can be set to **【On-Couple】**, **【Digital-In】**, **【Digital-Out】**, **【Trig-In】**, **【Trig-Out】**

This feature is designed to indicate the output status of the coupled channel in the output coupling. When the coupling relationship is selected and the coupled channel output is enabled, this pin outputs a signal externally.

Digital IO-7

IO-7 pin can be set to **【Off-Couple】**, **【Digital-In】**, **【Digital-Out】**, **【Trig-In】**, **【Trig-Out】**

This feature is designed to indicate the output-disabled state of the coupled channel in an output coupling configuration. When a coupling relationship is selected and the coupled channel's output is disabled, this pin outputs a signal externally.

Chapter8 Technical Specifications

This chapter will introduce the main technical parameters of IT2705, such as rated voltage/current/power and so on. Besides, this part will introduce the working environment and storage temperature.



NOTE

All the above parameters are subject to change without prior notice from ITECH.

8.1 Supplemental characteristics

Recommended calibration frequency: once a year

Cooling style: fans

8.2 Main technical parameters

IT2705 Main frame specifications

AC Input	Voltage	sing phase: 100V~240V	
	Frequency	50/60Hz	
Max. apparent power	2.2kVA		
Max. input current ⁽¹⁾	10.0Aac		
Max. efficiency	93%		
Power Factor	0.99		
DC component	≤0.2A		
Current harmonics	≤3%		
Max. Output current	Terminal post: 30A	Rubber plug: 10A	
Standard Interface	USB/LAN/CAN/Digit-IO		
Command Response Time	0.1ms		
Max. Channel	8		
Single channel max current	30A		
Display Size	7"		
Display resolution	800*400		
Working Temperature	0~40°C		
Storage Temperature	-10°C~70°C		
IP	IP20		
Isolation DC to GND	3500Vdc		
Cooling	Air		
Dimension(mm)	394mm(W)*195mm(H)*365.8mm(D) (main frame size)		

	394mm(W)*210.7mm(H)*395.35mm(D) (include feet, terminals size)
Weight(Main Frame)	8.5kg

Note:

(1) AC current will be limited to 10Aac and power limiting may occur at low input voltage. Example: AC input voltage is single phase 100Vac, power limit is: $P=100Vac*10Aac=1000VA$

IT27814

Rated value	Voltage	-20V~20V	
	Current	-3A~3A	
	Power	-20W~20W	
	Series internal resistance (CV Priority)	-0.04Ω~1Ω	
Setup Resolution	Voltage	6V range	6uV
		20V range	20uV
	Current	10mA range	0.1uA
		100mA range	1uA
		3A range	10uA
	Series internal resistance (CV Priority)	6V range	0.25mΩ
20V range		0.5mΩ	
Read Back Resolution	Voltage	6V range	6uV
		20V range	20uV
	Current	10uA range	100pA
		1mA range	10nA
		100mA range	1uA
		3A range	10uA
Setup Accuracy	Voltage	6V range	0.015% + 300μV
		20V range	0.015% + 1mV
	Current	10mA range	0.025% + 5 μA
		100mA range	0.025% + 10 μA
		3A range	0.03% + 250 μA
	Series internal resistance (CV Priority) (1)	6V range	0.1% + 1.5 mΩ
20V range		0.1% + 3 mΩ	
Read Back Accuracy	Voltage	6V range	0.015% + 300μV

	Current	20V range	0.015% + 1mV
		10uA range	0.025% + 8 nA
		1mA range	0.025% + 100 nA
		100mA range	0.025% + 10 μ A
		3A range	0.03% + 250 μ A
Voltage ripple	Vpeak		$\leq 12\text{mVpp}$
	Vrms		$\leq 1.2\text{mV}$
Transient Response Time (2)	Voltage	6V range with a 1.4A load step	$\leq 35\mu\text{s}$
		20V range with a 0.8A load step	$\leq 35\mu\text{s}$
Load Regulation	Voltage (3)	6V range	150 μ V
		20V range	400 μ V
	Current	10mA&100mA range	1 μ A
		1A range	50 μ A
		3A range	100 μ A
Output protection	OCP		-3.06A~3.06A
	OVP		-20.4V~20.4V
Remote Sense Compensation Voltage	$< 2\text{V}$		
Isolation DC to GND	600Vdc		
Working Temperature	0~40°C		
Storage Temperature	-10°C~70°C		
IP	IP20		
Cooling	Air		
Dimension (mm)	320mm(D)*104mm(W)*40.5mm(H)		
Weight(net)	0.95kg		

Note:

- (1) The voltage/current input is no less than 0.1A.
- (2) With 150 μ F cap (ESR=50 m Ω) at load, remote sensing at cap, the current rise time(10%-90%) is 10 μ s, settling band is $\pm 20\text{mV}/\pm 10\text{mV}$ under 6V/20V range.
- (3) Under sense mode

IT27814E

Rated value	Voltage	-20V~20V	
	Current	-3A~3A	
	Power	-20W~20W	
	Series internal resistance (CV Priority)	-0.04Ω~1Ω	
Setup Resolution	Voltage	6V range	210uV
		20V range	700uV
	Current	10mA range	1uA
		100mA range	10uA
		3A range	300uA
	Series internal resistance (CV Priority)	6V range	0.5mΩ
20V range		0.5mΩ	
Read Back Resolution	Voltage	6V range	210uV
		20V range	700uV
	Current	10uA range	1nA
		1mA range	100nA
		100mA range	10uA
		3A range	300uA
Setup Accuracy	Voltage	6V range	0.02% + 1mV
		20V range	0.02% + 3 mV
	Current	10mA range	0.05% + 6uA
		100mA range	0.05% + 50uA
		3A range	0.05% + 1.5mA
	Series internal resistance (CV Priority) (1)	6V range	0.1% + 1.5 mΩ
20V range		0.1% + 3 mΩ	
Read Back Accuracy	Voltage	6V range	0.02% + 1mV
		20V range	0.02% + 3 mV
	Current	10uA range	0.05% + 8 nA
		1mA range	0.05% + 400 nA
		100mA range	0.05% + 40 μA
		3A range	0.05% + 1.2 mA

Voltage ripple	Vpeak		≤12mVpp
	Vrms		≤1.2mV
Transient Response Time (2)	Voltage	6V range with a 1.4A load step	≤55μs
		20V range with a 0.8A load step	≤40μs
Load Regulation	Voltage (3)	6V range	600μV
		20V range	2mV
	Current	10mA&100mA range	3 μA
		1A range	200 μA
		3A range	400 μA
Output protection	OCP		-3.06A~3.06A
	OVP		-20.4V~20.4V
Remote Sense Compensation Voltage	<2V		
Isolation DC to GND	600Vdc		
Working Temperature	0~40°C		
Storage Temperature	-10°C~70°C		
IP	IP20		
Cooling	Air		
Dimension (mm)	320mm(D)*104mm(W)*40.5mm(H)		
Weight(net)	0.95kg		

Note:

- (1) The voltage/current input is no less than 0.1A.
- (2) With 150μF cap (ESR=50 mΩ) at load, remote sensing at cap, the current rise time(10%-90%) is 10us, settling band is ±20mV/±10mV under 6V/20V range.
- (3) Under sense mode

IT27134

Model	IT27134 DC power supply	
Rated value	Voltage	0~30V
	Current	0~15A
	Power	0~200W

	Series internal resistance (CV Priority)	0~1Ω
Setup Resolution	Voltage	0.001V
	Current	0.001A
	Power	0.01W
	Series internal resistance (CV Priority)	0.0001Ω
Read Back Resolution	Voltage	0.0001V
	Current	0.0001A
	Power	0.01W
Setup Accuracy	Voltage	≤0.02% + 0.02%FS
	Current	≤0.05% + 0.05%FS
	Power	≤0.1% + 0.2%FS
	Series internal resistance (CV Priority)	≤1%FS
Read Back Accuracy	Voltage	≤0.02% + 0.02%FS
	Current	≤0.05% + 0.05%FS
	Power	≤0.1% + 0.2%FS
Voltage ripple ⁽¹⁾	V _{peak}	≤30mV _{pp}
	V _{rms}	≤5mV
Setup Temperature Coefficient	Voltage	≤20ppm/°C
	Current	≤30ppm/°C
Read Back Temperature Coefficient	Voltage	≤20ppm/°C
	Current	≤30ppm/°C
Rise Time(no load)	Voltage	≤10ms
Rise Time(full load)	Voltage	≤20ms
Fall Time(no load)	Voltage	≤0.5s
Fall Time(full load)	Voltage	≤50ms
Transient Response Time ⁽²⁾	Time	≤1ms
	Stability Voltage	±0.3V

Line Regulation	Voltage	$\leq 0.005\% + 0.005\%FS$
	Current	$\leq 0.015\% + 0.015\%FS$
Load Regulation	Voltage ⁽³⁾	$\leq 0.005\% + 0.005\%FS$
	Current	$\leq 0.015\% + 0.015\%FS$
Output protection	OCP	15.3A
	OVP	30.6V
	OPP	204W
Remote Sense Compensation Voltage		$\leq 3V$
Isolation DC to GND		800Vdc
Working Temperature		0~40°C
Storage Temperature		-10°C~70°C
IP		IP20
Cooling		Air
Dimension (mm)		321mm(D)*51.7mm(W)*40.5mm(H)
Weight(net)		0.6kg

Note:

- (1) Ripple peak and RMS doubled for voltages 0.5V and below
- (2) 10% rated current to 90% rated current
- (3) Under sense mode
- (4) Voltage rise time from 10% to 90% of rated voltage and voltage fall time from 90% to 10% of rated voltage

IT27135

Model	IT27135 DC power supply	
Rated value	Voltage	0~60V
	Current	0~10A
	Power	0~200W
	Series internal resistance (CV Priority)	0~1Ω
Setup Resolution	Voltage	0.001V
	Current	0.001A

	Power	0.01W
	Series internal resistance (CV Priority)	0.0001Ω
Read Back Resolution	Voltage	0.0001V
	Current	0.0001A
	Power	0.01W
Setup Accuracy	Voltage	$\leq 0.02\% + 0.02\%FS$
	Current	$\leq 0.05\% + 0.05\%FS$
	Power	$\leq 0.1\% + 0.2\%FS$
	Series internal resistance (CV Priority)	$\leq 1\%FS$
Read Back Accuracy	Voltage	$\leq 0.02\% + 0.02\%FS$
	Current	$\leq 0.05\% + 0.05\%FS$
	Power	$\leq 0.1\% + 0.2\%FS$
Voltage ripple ⁽¹⁾	V _{peak}	$\leq 60mV_{pp}$
	V _{rms}	$\leq 10mV$
Setup Temperature Coefficient	Voltage	$\leq 20ppm/^{\circ}C$
	Current	$\leq 30ppm/^{\circ}C$
Read Back Temperature Coefficient	Voltage	$\leq 20ppm/^{\circ}C$
	Current	$\leq 30ppm/^{\circ}C$
Rise Time(no load)	Voltage	$\leq 10ms$
Rise Time(full load)	Voltage	$\leq 20ms$
Fall Time(no load)	Voltage	$\leq 0.5s$
Fall Time(full load)	Voltage	$\leq 50ms$
Transient Response Time ⁽²⁾	Time	$\leq 1ms$
	Stability Voltage	$\pm 0.6V$
Line Regulation	Voltage	$\leq 0.005\% + 0.005\%FS$
	Current	$\leq 0.015\% + 0.015\%FS$
Load Regulation	Voltage ⁽³⁾	$\leq 0.005\% + 0.005\%FS$
	Current	$\leq 0.015\% + 0.015\%FS$

Output protection	OCP	10.2A
	OVP	61.2V
	OPP	204W
Remote Sense Compensation Voltage	≤6V	
Isolation DC to GND	800Vdc	
Working Temperature	0~40°C	
Storage Temperature	-10°C~70°C	
IP	IP20	
Cooling	Air	
Dimension (mm)	321mm(D)*51.7mm(W)*40.5mm(H)	
Weight(net)	0.6kg	

Note:

- (1) Ripple peak and RMS doubled for voltages 0.5V and below
- (2) 10% rated current to 90% rated current
- (3) Under sense mode
- (4) Voltage rise time from 10% to 90% of rated voltage and voltage fall time from 90% to 10% of rated voltage

IT27137

Model	IT27137 DC power supply	
Rated value	Voltage	0~150V
	Current	0~5A
	Power	0~200W
	Series internal resistance (CV Priority)	0~1Ω
Setup Resolution	Voltage	0.01V
	Current	0.001A
	Power	0.01W
	Series internal resistance (CV Priority)	0.0001Ω
Read Back Resolution	Voltage	0.0001V
	Current	0.0001A
	Power	0.01W

Setup Accuracy	Voltage	$\leq 0.02\% + 0.02\%FS$
	Current	$\leq 0.05\% + 0.05\%FS$
	Power	$\leq 0.1\% + 0.2\%FS$
	Series internal resistance (CV Priority)	$\leq 1\%FS$
Read Back Accuracy	Voltage	$\leq 0.02\% + 0.02\%FS$
	Current	$\leq 0.05\% + 0.05\%FS$
	Power	$\leq 0.1\% + 0.2\%FS$
Voltage ripple ⁽¹⁾	V _{peak}	$\leq 150mV_{pp}$
	V _{rms}	$\leq 50mV$
Setup Temperature Coefficient	Voltage	$\leq 20ppm/^{\circ}C$
	Current	$\leq 30ppm/^{\circ}C$
Read Back Temperature Coefficient	Voltage	$\leq 20ppm/^{\circ}C$
	Current	$\leq 30ppm/^{\circ}C$
Rise Time(no load)	Voltage	$\leq 10ms$
Rise Time(full load)	Voltage	$\leq 20ms$
Fall Time(no load)	Voltage	$\leq 0.5s$
Fall Time(full load)	Voltage	$\leq 50ms$
Transient Response Time ⁽²⁾	Time	$\leq 1ms$
	Stability Voltage	$\pm 1.5V$
Line Regulation	Voltage	$\leq 0.005\% + 0.005\%FS$
	Current	$\leq 0.015\% + 0.015\%FS$
Load Regulation	Voltage ⁽³⁾	$\leq 0.005\% + 0.005\%FS$
	Current	$\leq 0.015\% + 0.015\%FS$
Output protection	OCP	5.1A
	OVP	153V
	OPP	204W
Remote Sense Compensation Voltage		$\leq 15V$
Isolation DC to GND		800Vdc

Working Temperature	0~40°C
Storage Temperature	-10°C~70°C
IP	IP20
Cooling	Air
Dimension (mm)	321mm(D)*51.7mm(W)*40.5mm(H)
Weight(net)	0.6kg

Note:

- (1) Ripple peak and RMS doubled for voltages 0.5V and below
- (2) 10% rated current to 90% rated current
- (3) Under sense mode
- (4) Voltage rise time from 10% to 90% of rated voltage and voltage fall time from 90% to 10% of rated voltage

IT27154

Model	IT27154 DC power supply	
Rated value	Voltage	0~30V
	Current	0~30A
	Power	0~500W
	Series internal resistance (CV Priority)	0~1Ω
Setup Resolution	Voltage	0.001V
	Current	0.001A
	Power	0.01W
	Series internal resistance (CV Priority)	0.0001Ω
Read Back Resolution	Voltage	0.0001V
	Current	0.0001A
	Power	0.01W
Setup Accuracy	Voltage	≤0.02% + 0.02%FS
	Current	≤0.05% + 0.05%FS
	Power	≤0.1% + 0.2%FS
	Series internal resistance (CV Priority)	≤1%FS
Read Back Accuracy	Voltage	≤0.02% + 0.02%FS

	Current	$\leq 0.05\% + 0.05\%FS$
	Power	$\leq 0.1\% + 0.2\%FS$
Voltage ripple ⁽¹⁾	Vpeak	$\leq 30mVpp$
	Vrms	$\leq 5mV$
Setup Temperature Coefficient	Voltage	$\leq 20ppm/^{\circ}C$
	Current	$\leq 30ppm/^{\circ}C$
Read Back Temperature Coefficient	Voltage	$\leq 20ppm/^{\circ}C$
	Current	$\leq 30ppm/^{\circ}C$
Rise Time(no load)	Voltage	$\leq 10ms$
Rise Time(full load)	Voltage	$\leq 20ms$
Fall Time(no load)	Voltage	$\leq 0.5s$
Fall Time(full load)	Voltage	$\leq 50ms$
Transient Response Time ⁽²⁾	Voltage	$\leq 1ms$
	Stability Voltage	$\pm 0.3V$
Line Regulation	Voltage	$\leq 0.005\% + 0.005\%FS$
	Current	$\leq 0.015\% + 0.015\%FS$
Load Regulation	Voltage ⁽³⁾	$\leq 0.005\% + 0.005\%FS$
	Current	$\leq 0.015\% + 0.015\%FS$
Output protection	OCP	30.6A
	OVP	30.6V
	OPP	510W
Remote Sense Compensation Voltage	$\leq 3V$	
Isolation DC to GND	800Vdc	
Working Temperature	0~40°C	
Storage Temperature	-10°C~70°C	
IP	IP20	
Cooling	Air	
Dimension (mm)	321mm(D)*104mm(W)*40.5mm(H)	

Weight(net)	1.0kg
--------------	-------

Note:

- (1) Ripple peak and RMS doubled for voltages 0.5V and below
- (2) 10% rated current to 90% rated current
- (3) Under sense mode
- (4) Voltage rise time from 10% to 90% of rated voltage and voltage fall time from 90% to 10% of rated voltage

IT27155

Model	IT27155 DC power supply	
Rated value	Voltage	0~60V
	Current	0~20A
	Power	0~500W
	Series internal resistance (CV Priority)	0~1Ω
Setup Resolution	Voltage	0.001V
	Current	0.001A
	Power	0.01W
	Series internal resistance (CV Priority)	0.0001Ω
Read Back Resolution	Voltage	0.0001V
	Current	0.0001A
	Power	0.01W
Setup Accuracy	Voltage	≤0.02% + 0.02%FS
	Current	≤0.05% + 0.05%FS
	Power	≤0.1% + 0.2%FS
	Series internal resistance (CV Priority)	≤1%FS
Read Back Accuracy	Voltage	≤0.02% + 0.02%FS
	Current	≤0.05% + 0.05%FS
	Power	≤0.1% + 0.2%FS
Voltage ripple ⁽¹⁾	V _{peak}	≤60mV _{pp}
	V _{rms}	≤10mV
Setup Temperature	Voltage	≤20ppm/°C

Coefficient	Current	$\leq 30\text{ppm}/^{\circ}\text{C}$
Read Back Temperature Coefficient	Voltage	$\leq 20\text{ppm}/^{\circ}\text{C}$
	Current	$\leq 30\text{ppm}/^{\circ}\text{C}$
Rise Time(no load)	Voltage	$\leq 10\text{ms}$
Rise Time(full load)	Voltage	$\leq 20\text{ms}$
Fall Time(no load)	Voltage	$\leq 0.5\text{s}$
Fall Time(full load)	Voltage	$\leq 50\text{ms}$
Transient Response Time ⁽²⁾	Time	$\leq 1\text{ms}$
	Stability Voltage	$\pm 0.6\text{V}$
Line Regulation	Voltage	$\leq 0.005\% + 0.005\%\text{FS}$
	Current	$\leq 0.015\% + 0.015\%\text{FS}$
Load Regulation	Voltage ⁽³⁾	$\leq 0.005\% + 0.005\%\text{FS}$
	Current	$\leq 0.015\% + 0.015\%\text{FS}$
Output protection	OCP	20.4A
	OVP	61.2V
	OPP	510W
Remote Sense Compensation Voltage		$\leq 6\text{V}$
Isolation DC to GND		800Vdc
Working Temperature		0~40°C
Storage Temperature		-10°C~70°C
IP		IP20
Cooling		Air
Dimension (mm)		321mm(D)*104mm(W)*40.5mm(H)
Weight(net)		1.0kg

Note:

- (1) Ripple peak and RMS doubled for voltages 0.5V and below
- (2) 10% rated current to 90% rated current
- (3) Under sense mode
- (4) Voltage rise time from 10% to 90% of rated voltage and voltage fall time from 90% to 10% of rated voltage

IT27157

Model	IT27157 DC power supply	
Rated value	Voltage	0~150V
	Current	0~10A
	Power	0~500W
	Series internal resistance (CV Priority)	0~1Ω
Setup Resolution	Voltage	0.01V
	Current	0.001A
	Power	0.01W
	Series internal resistance (CV Priority)	0.0001Ω
Read Back Resolution	Voltage	0.0001V
	Current	0.0001A
	Power	0.01W
Setup Accuracy	Voltage	≤0.02% + 0.02%FS
	Current	≤0.05% + 0.05%FS
	Power	≤0.1% + 0.2%FS
	Series internal resistance (CV Priority)	≤1%FS
Read Back Accuracy	Voltage	≤0.02% + 0.02%FS
	Current	≤0.05% + 0.05%FS
	Power	≤0.1% + 0.2%FS
Voltage ripple ⁽¹⁾	V _{peak}	≤150mV _{pp}
	V _{rms}	≤50mV
Setup Temperature Coefficient	Voltage	≤20ppm/°C
	Current	≤30ppm/°C
Read Back Temperature Coefficient	Voltage	≤20ppm/°C
	Current	≤30ppm/°C
Rise Time(no load)	Voltage	≤10ms

Rise Time(full load)	Voltage	≤20ms
Fall Time(no load)	Voltage	≤0.5s
Fall Time(full load)	Voltage	≤50ms
Transient Response Time ⁽²⁾	Time	≤1ms
	Stability Voltage	±1.5V
Line Regulation	Voltage	≤0.005% + 0.005%FS
	Current	≤0.015% + 0.015%FS
Load Regulation	Voltage ⁽³⁾	≤0.005% + 0.005%FS
	Current	≤0.015% + 0.015%FS
Output protection	OCP	10.2A
	OVP	153V
	OPP	510W
Remote Sense Compensation Voltage	≤15V	
Isolation DC to GND	800Vdc	
Working Temperature	0~40°C	
Storage Temperature	-10°C~70°C	
IP	IP20	
Cooling	Air	
Dimension (mm)	321mm(D)*104mm(W)*40.5mm(H)	
Weight(net)	1.0kg	

Note:

- (1) Ripple peak and RMS doubled for voltages 0.5V and below
- (2) 10% rated current to 90% rated current
- (3) Under sense mode
- (4) Voltage rise time from 10% to 90% of rated voltage and voltage fall time from 90% to 10% of rated voltage

IT27334

Model	IT27334 Bidirectional DC power supply	
Rated value	Voltage	0~30V
	Current	-15A~15A

	Power	-200W~200W
	Series internal resistance (CV Priority)	0~1Ω
	Load internal resistance (CC Priority)	0.04Ω~200Ω
	Min. operating voltage (Sink mode)	0.6V at 15A
Setup Resolution	Voltage	0.001V
	Current	0.001A
	Power	0.01W
	Series internal resistance (CV Priority)	0.0001Ω
	Load internal resistance (CC Priority)	0.01Ω
Read Back Resolution	Voltage	0.0001V
	Current	0.0001A
	Power	0.01W
Setup Accuracy	Voltage	≤0.02% + 0.02%FS
	Current	≤0.05% + 0.05%FS
	Power	≤0.1% + 0.2%FS
	Series internal resistance (CV Priority)	≤1%FS
	Load internal resistance (CC Priority) ⁽¹⁾	(Vin/Rset)*0.5%+0.5%FS
Read Back Accuracy	Voltage	≤0.02% + 0.02%FS
	Current	≤0.05% + 0.05%FS
	Power	≤0.1% + 0.2%FS
Voltage ripple ⁽²⁾	Vpeak	≤30mVpp
	Vrms	≤5mV
Setup Temperature Coefficient	Voltage	≤20ppm/°C
	Current	≤30ppm/°C
Read Back Temperature Coefficient	Voltage	≤20ppm/°C
	Current	≤30ppm/°C
Rise Time(no load)	Voltage	≤10ms

Rise Time(full load)	Voltage	≤20ms
Fall Time(no load)	Voltage	≤10ms
Fall Time(full load)	Voltage	≤10ms
Transient Response Time ⁽³⁾	Time	≤1ms
	Stability Voltage	±0.3V
Line Regulation	Voltage	≤0.005% + 0.005%FS
	Current	≤0.015% + 0.015%FS
Load Regulation	Voltage ⁽⁴⁾	≤0.005% + 0.005%FS
	Current	≤0.015% + 0.015%FS
Output protection	OCP	-15.3A or 15.3A
	OVP	30.6V
	OPP	-204W or 204W
Remote Sense Compensation Voltage	≤3V	
Isolation DC to GND	800Vdc	
Working Temperature	0~40°C	
Storage Temperature	-10°C~70°C	
IP	IP20	
Cooling	Air	
Dimension (mm)	321mm(D)*51.7mm(W)*40.5mm(H)	
Weight(net)	0.6kg	

Note:

- (1) The voltage/current input is no less than 10%FS.
- (2) Ripple peak and RMS doubled for voltages 0.5V and below
- (3) 10% rated current to 90% rated current
- (4) Under sense mode
- (5) Voltage rise time from 10% to 90% of rated voltage and voltage fall time from 90% to 10% of rated voltage

IT27335

Model	IT27335 Bidirectional DC power supply	
Rated value	Voltage	0~60V

	Current	-10A~10A
	Power	-200W~200W
	Series internal resistance (CV Priority)	0~1Ω
	Load internal resistance (CC Priority)	0.06Ω~600Ω
	Min. operating voltage (Sink mode)	0.6V at 10A
Setup Resolution	Voltage	0.001V
	Current	0.001A
	Power	0.01W
	Series internal resistance (CV Priority)	0.0001Ω
	Load internal resistance (CC Priority)	0.01Ω
Read Back Resolution	Voltage	0.0001V
	Current	0.0001A
	Power	0.01W
Setup Accuracy	Voltage	$\leq 0.02\% + 0.02\%FS$
	Current	$\leq 0.05\% + 0.05\%FS$
	Power	$\leq 0.1\% + 0.2\%FS$
	Series internal resistance (CV Priority)	$\leq 1\%FS$
	Load internal resistance (CC Priority) ⁽¹⁾	$(V_{in}/R_{set}) * 0.5\% + 0.5\%FS$
Read Back Accuracy	Voltage	$\leq 0.02\% + 0.02\%FS$
	Current	$\leq 0.05\% + 0.05\%FS$
	Power	$\leq 0.1\% + 0.2\%FS$
Voltage ripple ⁽²⁾	V _{peak}	$\leq 60mV_{pp}$
	V _{rms}	$\leq 10mV$
Setup Temperature Coefficient	Voltage	$\leq 20ppm/^{\circ}C$
	Current	$\leq 30ppm/^{\circ}C$
Read Back Temperature Coefficient	Voltage	$\leq 20ppm/^{\circ}C$
	Current	$\leq 30ppm/^{\circ}C$

Rise Time(no load)	Voltage	≤10ms
Rise Time(full load)	Voltage	≤20ms
Fall Time(no load)	Voltage	≤10ms
Fall Time(full load)	Voltage	≤10ms
Transient Response Time ⁽³⁾	Time	≤1ms
	Stability Voltage	±0.6V
Line Regulation	Voltage	≤0.005% + 0.005%FS
	Current	≤0.015% + 0.015%FS
Load Regulation	Voltage ⁽⁴⁾	≤0.005% + 0.005%FS
	Current	≤0.015% + 0.015%FS
Output protection	OCP	-10.2A or 10.2A
	OVP	61.2V
	OPP	-204W or 204W
Remote Sense Compensation Voltage	≤6V	
Isolation DC to GND	800Vdc	
Working Temperature	0~40°C	
Storage Temperature	-10°C~70°C	
IP	IP20	
Cooling	Air	
Dimension (mm)	321mm(D)*51.7mm(W)*40.5mm(H)	
Weight(net)	0.6kg	

Note:

- (1) The voltage/current input is no less than 10%FS.
- (2) Ripple peak and RMS doubled for voltages 0.5V and below
- (3) 10% rated current to 90% rated current
- (4) Under sense mode
- (5) Voltage rise time from 10% to 90% of rated voltage and voltage fall time from 90% to 10% of rated voltage

IT27337

Model	IT27337 Bidirectional DC power supply
-------	---------------------------------------

Rated value	Voltage	0~150V
	Current	-5A~5A
	Power	-200W~200W
	Series internal resistance (CV Priority)	0~1Ω
	Load internal resistance (CC Priority)	0.5Ω~3000Ω
	Min. operating voltage (Sink mode)	25V at 5A
Setup Resolution	Voltage	0.01V
	Current	0.001A
	Power	0.01W
	Series internal resistance (CV Priority)	0.0001Ω
	Load internal resistance (CC Priority)	0.01Ω
Read Back Resolution	Voltage	0.0001V
	Current	0.0001A
	Power	0.01W
Setup Accuracy	Voltage	$\leq 0.02\% + 0.02\%FS$
	Current	$\leq 0.05\% + 0.05\%FS$
	Power	$\leq 0.1\% + 0.2\%FS$
	Series internal resistance (CV Priority)	$\leq 1\%FS$
	Load internal resistance (CC Priority) ⁽¹⁾	$(V_{in}/R_{set}) * 0.5\% + 0.5\%FS$
Read Back Accuracy	Voltage	$\leq 0.02\% + 0.02\%FS$
	Current	$\leq 0.05\% + 0.05\%FS$
	Power	$\leq 0.1\% + 0.2\%FS$
Voltage ripple ⁽²⁾	V _{peak}	$\leq 150mV_{pp}$
	V _{rms}	$\leq 50mV$
Setup Temperature Coefficient	Voltage	$\leq 20ppm/^{\circ}C$
	Current	$\leq 30ppm/^{\circ}C$
Read Back Temperature Coefficient	Voltage	$\leq 20ppm/^{\circ}C$

	Current	$\leq 30\text{ppm}/^{\circ}\text{C}$
Rise Time(no load)	Voltage	$\leq 10\text{ms}$
Rise Time(full load)	Voltage	$\leq 20\text{ms}$
Fall Time(no load)	Voltage	$\leq 10\text{ms}$
Fall Time(full load)	Voltage	$\leq 10\text{ms}$
Transient Response Time (3)	Voltage	$\leq 1\text{ms}$
	Stability Voltage	$\pm 1.5\text{V}$
Line Regulation	Voltage	$\leq 0.005\% + 0.005\%\text{FS}$
	Current	$\leq 0.015\% + 0.015\%\text{FS}$
Load Regulation	Voltage (4)	$\leq 0.005\% + 0.005\%\text{FS}$
	Current	$\leq 0.015\% + 0.015\%\text{FS}$
Output protection	OCP	-5.1A or 5.1A
	OVP	153V
	OPP	-204W or 204W
Remote Sense Compensation Voltage	$\leq 15\text{V}$	
Isolation DC to GND	800Vdc	
Working Temperature	0~40°C	
Storage Temperature	-10°C~70°C	
IP	IP20	
Cooling	Air	
Dimension (mm)	321mm(D)*51.7mm(W)*40.5mm(H)	
Weight(net)	0.6kg	

Note:

- (1) The voltage/current input is no less than 10%FS.
- (2) Ripple peak and RMS doubled for voltages 0.5V and below
- (3) 10% rated current to 90% rated current
- (4) Under sense mode
- (5) Voltage rise time from 10% to 90% of rated voltage and voltage fall time from 90% to 10% of rated voltage

IT27354

Model	IT27354 Bidirectional DC power supply	
Rated value	Voltage	0~30V
	Current	-30A~30A
	Power	-500W~500W
	Series internal resistance (CV Priority)	0~1Ω
	Load internal resistance (CC Priority)	0.03Ω~100Ω
	Min. operating voltage (Sink mode)	0.9V at 30A
Setup Resolution	Voltage	0.001V
	Current	0.001A
	Power	0.01W
	Series internal resistance (CV Priority)	0.0001Ω
	Load internal resistance (CC Priority)	0.01Ω
Read Back Resolution	Voltage	0.0001V
	Current	0.0001A
	Power	0.01W
Setup Accuracy	Voltage	≤0.02% + 0.02%FS
	Current	≤0.05% + 0.05%FS
	Power	≤0.1% + 0.2%FS
	Series internal resistance (CV Priority)	≤1%FS
	Load internal resistance (CC Priority) ⁽¹⁾	(Vin/Rset)*0.5%+0.5%FS
Read Back Accuracy	Voltage	≤0.02% + 0.02%FS
	Current	≤0.05% + 0.05%FS
	Power	≤0.1% + 0.2%FS
Voltage ripple ⁽²⁾	V _{peak}	≤30mV _{pp}
	V _{rms}	≤5mV
Setup Temperature Coefficient	Voltage	≤20ppm/°C
	Current	≤30ppm/°C

Read Back Temperature Coefficient	Voltage	$\leq 20\text{ppm}/^{\circ}\text{C}$
	Current	$\leq 30\text{ppm}/^{\circ}\text{C}$
Rise Time(no load)	Voltage	$\leq 10\text{ms}$
Rise Time(full load)	Voltage	$\leq 20\text{ms}$
Fall Time(no load)	Voltage	$\leq 10\text{ms}$
Fall Time(full load)	Voltage	$\leq 10\text{ms}$
Transient Response Time ⁽³⁾	Time	$\leq 1\text{ms}$
	Stability Voltage	$\pm 0.3\text{V}$
Line Regulation	Voltage	$\leq 0.005\% + 0.005\%\text{FS}$
	Current	$\leq 0.015\% + 0.015\%\text{FS}$
Load Regulation	Voltage ⁽⁴⁾	$\leq 0.005\% + 0.005\%\text{FS}$
	Current	$\leq 0.015\% + 0.015\%\text{FS}$
Output protection	OCP	-30.6A or 30.6A
	OVP	30.6V
	OPP	-510W or 510W
Remote Sense Compensation Voltage	$\leq 3\text{V}$	
Isolation DC to GND	800Vdc	
Working Temperature	0~40°C	
Storage Temperature	-10°C~70°C	
IP	IP20	
Cooling	Air	
Dimension (mm)	321mm(D)*104mm(W)*40.5mm(H)	
Weight(net)	1.0kg	

Note:

- (1) The voltage/current input is no less than 10%FS.
- (2) Ripple peak and RMS doubled for voltages 0.5V and below
- (3) 10% rated current to 90% rated current
- (4) Under sense mode
- (5) Voltage rise time from 10% to 90% of rated voltage and voltage fall time from 90% to 10% of rated voltage

IT27355

Model	IT27355 Bidirectional DC power supply	
Rated value	Voltage	0~60V
	Current	-20A~20A
	Power	-500W~500W
	Series internal resistance (CV Priority)	0~1Ω
	Load internal resistance (CC Priority)	0.03Ω~300Ω
	Min. operating voltage (Sink mode)	0.6V at 20A
Setup Resolution	Voltage	0.001V
	Current	0.001A
	Power	0.01W
	Series internal resistance (CV Priority)	0.0001Ω
	Load internal resistance (CC Priority)	0.01Ω
Read Back Resolution	Voltage	0.0001V
	Current	0.0001A
	Power	0.01W
Setup Accuracy	Voltage	≤0.02% + 0.02%FS
	Current	≤0.05% + 0.05%FS
	Power	≤0.1% + 0.2%FS
	Series internal resistance (CV Priority)	≤1%FS
	Load internal resistance (CC Priority) ⁽¹⁾	(Vin/Rset)*0.5%+0.5%FS
Read Back Accuracy	Voltage	≤0.02% + 0.02%FS
	Current	≤0.05% + 0.05%FS
	Power	≤0.1% + 0.2%FS
Voltage ripple ⁽²⁾	V _{peak}	≤60mV _{pp}
	V _{rms}	≤10mV
Setup Temperature Coefficient	Voltage	≤20ppm/°C
	Current	≤30ppm/°C

Read Back Temperature Coefficient	Voltage	$\leq 20\text{ppm}/^{\circ}\text{C}$
	Current	$\leq 30\text{ppm}/^{\circ}\text{C}$
Rise Time(no load)	Voltage	$\leq 10\text{ms}$
Rise Time(full load)	Voltage	$\leq 20\text{ms}$
Fall Time(no load)	Voltage	$\leq 10\text{ms}$
Fall Time(full load)	Voltage	$\leq 10\text{ms}$
Transient Response Time ⁽³⁾	Time	$\leq 1\text{ms}$
	Stability Voltage	$\pm 0.6\text{V}$
Line Regulation	Voltage	$\leq 0.005\% + 0.005\%\text{FS}$
	Current	$\leq 0.015\% + 0.015\%\text{FS}$
Load Regulation	Voltage ⁽⁴⁾	$\leq 0.005\% + 0.005\%\text{FS}$
	Current	$\leq 0.015\% + 0.015\%\text{FS}$
Output protection	OCP	-20.4A or 20.4A
	OVP	61.2V
	OPP	-510W or 510W
Remote Sense Compensation Voltage	$\leq 6\text{V}$	
Isolation DC to GND	800Vdc	
Working Temperature	0~40°C	
Storage Temperature	-10°C~70°C	
IP	IP20	
Cooling	Air	
Dimension (mm)	321mm(D)*104mm(W)*40.5mm(H)	
Weight(net)	1.0kg	

Note:

- (1) The voltage/current input is no less than 10%FS.
- (2) Ripple peak and RMS doubled for voltages 0.5V and below
- (3) 10% rated current to 90% rated current
- (4) Under sense mode
- (5) Voltage rise time from 10% to 90% of rated voltage and voltage fall time from 90% to 10% of rated voltage

IT27357

Model	IT27357 Bidirectional DC power supply	
Rated value	Voltage	0~150V
	Current	-10A~10A
	Power	-500W~500W
	Series internal resistance (CV Priority)	0~1Ω
	Load internal resistance (CC Priority)	0.17Ω~1500Ω
	Min. operating voltage (Sink mode)	1.7V at 10A
Setup Resolution	Voltage	0.01V
	Current	0.001A
	Power	0.01W
	Series internal resistance (CV Priority)	0.0001Ω
	Load internal resistance (CC Priority)	0.01Ω
Read Back Resolution	Voltage	0.0001V
	Current	0.0001A
	Power	0.01W
Setup Accuracy	Voltage	≤0.02% + 0.02%FS
	Current	≤0.05% + 0.05%FS
	Power	≤0.1% + 0.2%FS
	Series internal resistance (CV Priority)	≤1%FS
	Load internal resistance (CC Priority) ⁽¹⁾	(Vin/Rset)*0.5%+0.5%FS
Read Back Accuracy	Voltage	≤0.02% + 0.02%FS
	Current	≤0.05% + 0.05%FS
	Power	≤0.1% + 0.2%FS
Voltage ripple ⁽²⁾	Vpeak	≤150mVpp
	Vrms	≤50mV
Setup Temperature Coefficient	Voltage	≤20ppm/°C
	Current	≤30ppm/°C

Read Back Temperature Coefficient	Voltage	$\leq 20\text{ppm}/^{\circ}\text{C}$
	Current	$\leq 30\text{ppm}/^{\circ}\text{C}$
Rise Time(no load)	Voltage	$\leq 10\text{ms}$
Rise Time(full load)	Voltage	$\leq 20\text{ms}$
Fall Time(no load)	Voltage	$\leq 10\text{ms}$
Fall Time(full load)	Voltage	$\leq 10\text{ms}$
Transient Response Time ⁽³⁾	Time	$\leq 1\text{ms}$
	Stability Voltage	$\pm 1.5\text{V}$
Line Regulation	Voltage	$\leq 0.005\% + 0.005\%\text{FS}$
	Current	$\leq 0.015\% + 0.015\%\text{FS}$
Load Regulation	Voltage ⁽⁴⁾	$\leq 0.005\% + 0.005\%\text{FS}$
	Current	$\leq 0.015\% + 0.015\%\text{FS}$
Output protection	OCP	-10.2A or 10.2A
	OVP	153V
	OPP	-510W or 510W
Remote Sense Compensation Voltage	$\leq 15\text{V}$	
Isolation DC to GND	800Vdc	
Working Temperature	0~40°C	
Storage Temperature	-10°C~70°C	
IP	IP20	
Cooling	Air	
Dimension (mm)	321mm(D)*104mm(W)*40.5mm(H)	
Weight(net)	1.0kg	

Note:

- (1) The voltage/current input is no less than 10%FS.
- (2) Ripple peak and RMS doubled for voltages 0.5V and below
- (3) 10% rated current to 90% rated current
- (4) Under sense mode
- (5) Voltage rise time from 10% to 90% of rated voltage and voltage fall time from 90% to 10% of rated voltage

IT27534

Model	IT27534 Programmable DC Load	
Rated value	Voltage	0.03V~30V
	Current	0~15A
	Power	0~200W
	Resistance	0.04Ω~200Ω
	Min. operating voltage	0.6V at 15A
	Input leakage current	0.001A
Setup Resolution	Voltage	0.001V
	Current	0.001A
	Power	0.01W
	Resistance	0.01Ω
Read Back Resolution	Voltage	0.0001V
	Current	0.0001A
	Power	0.01W
Setup Accuracy	Voltage	≤0.02% + 0.02%FS
	Current	≤0.05% + 0.05%FS
	Power	≤0.1% + 0.2%FS
	Resistance ⁽¹⁾	(Vin/Rset)*0.5%+0.5%FS
Read Back Accuracy	Voltage	≤0.02% + 0.02%FS
	Current	≤0.05% + 0.05%FS
	Power	≤0.1% + 0.2%FS
Setup Temperature Coefficient	Voltage	≤20ppm/°C
	Current	≤30ppm/°C
Read Back Temperature Coefficient	Voltage	≤20ppm/°C
	Current	≤30ppm/°C
Current Slope	Rising slope	15A/ms
	Falling slope	15A/ms
Line Regulation	Voltage	≤0.005% + 0.005%FS
	Current	≤0.015% + 0.015%FS
Load Regulation	Voltage ⁽²⁾	≤0.005% + 0.005%FS
	Current	≤0.015% + 0.015%FS
Isc	Current	15.75A
Input protection	OCP	15.3A

	OVP	30.6V
	OPP	204W
Input OVP	31.5V	
Remote Sense Compensation Voltage	≤3V	
Isolation DC to GND	800Vdc	
Working Temperature	0~40°C	
Storage Temperature	-10°C~70°C	
IP	IP20	
Cooling	Air	
Dimension (mm)	321mm(D)*51.7mm(W)*40.5mm(H)	
Weight(net)	0.6kg	

Note:

- (1) The voltage/current input is not less than 10%FS.
- (2) Under sense mode

IT27535

Model	IT27535 Programmable DC Load	
Rated value	Voltage	0.06V~60V
	Current	0~10A
	Power	0~200W
	Resistance	0.06Ω~600Ω
	Min. operating voltage	0.6V at 10A
	Input leakage current	0.001A
Setup Resolution	Voltage	0.001V
	Current	0.001A
	Power	0.01W
	Resistance	0.01Ω
Read Back Resolution	Voltage	0.0001V
	Current	0.0001A
	Power	0.01W
Setup Accuracy	Voltage	≤0.02% + 0.02%FS
	Current	≤0.05% + 0.05%FS
	Power	≤0.1% + 0.2%FS
	Resistance ⁽¹⁾	(Vin/Rset)*0.5%+0.5%FS

Read Back Accuracy	Voltage	$\leq 0.02\% + 0.02\%FS$
	Current	$\leq 0.05\% + 0.05\%FS$
	Power	$\leq 0.1\% + 0.2\%FS$
Setup Temperature Coefficient	Voltage	$\leq 20ppm/^{\circ}C$
	Current	$\leq 30ppm/^{\circ}C$
Read Back Temperature Coefficient	Voltage	$\leq 20ppm/^{\circ}C$
	Current	$\leq 30ppm/^{\circ}C$
Current Slope	Rising slope	10A/ms
	Falling slope	10A/ms
Line Regulation	Voltage	$\leq 0.005\% + 0.005\%FS$
	Current	$\leq 0.015\% + 0.015\%FS$
Load Regulation	Voltage ⁽²⁾	$\leq 0.005\% + 0.005\%FS$
	Current	$\leq 0.015\% + 0.015\%FS$
Isc	Current	10.5A
Input protection	OCP	10.2A
	OVP	61.2V
	OPP	204W
Input OVP	63V	
Remote Sense Compensation Voltage	$\leq 6V$	
Isolation DC to GND	800Vdc	
Working Temperature	0~40°C	
Storage Temperature	-10°C~70°C	
IP	IP20	
Cooling	Air	
Dimension (mm)	321mm(D)*51.7mm(W)*40.5mm(H)	
Weight(net)	0.6kg	

Note:

- (1) The voltage/current input is not less than 10%FS.
- (2) Under sense mode

IT27537

Model	IT27537 Programmable DC Load	
Rated value	Voltage	0.150V~150V

	Current	0~5A
	Power	0~200W
	Resistance	0.5Ω~3000Ω
	Min. operating voltage	2.5V at 5A
	Input leakage current	0.001A
Setup Resolution	Voltage	0.01V
	Current	0.001A
	Power	0.01W
	Resistance	0.01Ω
Read Back Resolution	Voltage	0.0001V
	Current	0.0001A
	Power	0.01W
Setup Accuracy	Voltage	$\leq 0.02\% + 0.02\%FS$
	Current	$\leq 0.05\% + 0.05\%FS$
	Power	$\leq 0.1\% + 0.2\%FS$
	Resistance ⁽¹⁾	$(V_{in}/R_{set}) * 0.5\% + 0.5\%FS$
Read Back Accuracy	Voltage	$\leq 0.02\% + 0.02\%FS$
	Current	$\leq 0.05\% + 0.05\%FS$
	Power	$\leq 0.1\% + 0.2\%FS$
Setup Temperature Coefficient	Voltage	$\leq 20ppm/^{\circ}C$
	Current	$\leq 30ppm/^{\circ}C$
Read Back Temperature Coefficient	Voltage	$\leq 20ppm/^{\circ}C$
	Current	$\leq 30ppm/^{\circ}C$
Current Slope	Rising slope	5A/ms
	Falling slope	5A/ms
Line Regulation	Voltage	$\leq 0.005\% + 0.005\%FS$
	Current	$\leq 0.015\% + 0.015\%FS$

Load Regulation	Voltage ⁽²⁾	$\leq 0.005\% + 0.005\%FS$
	Current	$\leq 0.015\% + 0.015\%FS$
Isc	Current	5.25A
Input protection	OCP	5.1A
	OVP	153V
	OPP	204W
Input OVP	156V	
Remote Sense Compensation Voltage	$\leq 15V$	
Isolation DC to GND	800Vdc	
Working Temperature	0~40°C	
Storage Temperature	-10°C~70°C	
IP	IP20	
Cooling	Air	
Dimension (mm)	321mm(D)*51.7mm(W)*40.5mm(H)	
Weight(net)	0.6kg	

Note:

- (1) The voltage/current input is not less than 10%FS.
- (2) Under sense mode

IT27554

Model	IT27554 Programmable DC Load	
Rated value	Voltage	0.03V~30V
	Current	0~30A
	Power	0~500W
	Resistance	0.03Ω~100Ω
	Min. operating voltage	0.9V at 30A
	Input leakage current	0.001A
Setup Resolution	Voltage	0.001V

	Current	0.001A
	Power	0.01W
	Resistance	0.01Ω
Read Back Resolution	Voltage	0.0001V
	Current	0.0001A
	Power	0.01W
Setup Accuracy	Voltage	$\leq 0.02\% + 0.02\%FS$
	Current	$\leq 0.05\% + 0.05\%FS$
	Power	$\leq 0.1\% + 0.2\%FS$
	Resistance ⁽¹⁾	$(V_{in}/R_{set}) * 0.5\% + 0.5\%FS$
Read Back Accuracy	Voltage	$\leq 0.02\% + 0.02\%FS$
	Current	$\leq 0.05\% + 0.05\%FS$
	Power	$\leq 0.1\% + 0.2\%FS$
Setup Temperature Coefficient	Voltage	$\leq 20ppm/^{\circ}C$
	Current	$\leq 30ppm/^{\circ}C$
Read Back Temperature Coefficient	Voltage	$\leq 20ppm/^{\circ}C$
	Current	$\leq 30ppm/^{\circ}C$
Current Slope	Rising slope	30A/ms
	Falling slope	30A/ms
Line Regulation	Voltage	$\leq 0.005\% + 0.005\%FS$
	Current	$\leq 0.015\% + 0.015\%FS$
Load Regulation	Voltage ⁽²⁾	$\leq 0.005\% + 0.005\%FS$
	Current	$\leq 0.015\% + 0.015\%FS$
Isc	Current	31.5A
Input protection	OCP	30.6A
	OVP	30.6V
	OPP	510W
Input OVP	31.5V	

Remote Sense Compensation Voltage	$\leq 3V$
Isolation DC to GND	800Vdc
Working Temperature	0~40°C
Storage Temperature	-10°C~70°C
IP	IP20
Cooling	Air
Dimension (mm)	321mm(D)*104mm(W)*40.5mm(H)
Weight(net)	1.0kg

Note:

- (1) The voltage/current input is not less than 10%FS.
- (2) Under sense mode

IT27555

Model	IT27555 Programmable DC Load	
Rated value	Voltage	0.06V~60V
	Current	0~20A
	Power	0~500W
	Resistance	0.03Ω~300Ω
	Min. operating voltage	0.6V at 20A
	Input leakage current	0.001A
Setup Resolution	Voltage	0.001V
	Current	0.001A
	Power	0.01W
	Resistance	0.01Ω
Read Back Resolution	Voltage	0.0001V
	Current	0.0001A
	Power	0.01W
Setup Accuracy	Voltage	$\leq 0.02\% + 0.02\%FS$
	Current	$\leq 0.05\% + 0.05\%FS$

	Power	$\leq 0.1\% + 0.2\%FS$
	Resistance ⁽¹⁾	$(V_{in}/R_{set}) * 0.5\% + 0.5\%FS$
Read Back Accuracy	Voltage	$\leq 0.02\% + 0.02\%FS$
	Current	$\leq 0.05\% + 0.05\%FS$
	Power	$\leq 0.1\% + 0.2\%FS$
Setup Temperature Coefficient	Voltage	$\leq 20ppm/^{\circ}C$
	Current	$\leq 30ppm/^{\circ}C$
Read Back Temperature Coefficient	Voltage	$\leq 20ppm/^{\circ}C$
	Current	$\leq 30ppm/^{\circ}C$
Current Slope	Rising slope	20A/ms
	Falling slope	20A/ms
Line Regulation	Voltage	$\leq 0.005\% + 0.005\%FS$
	Current	$\leq 0.015\% + 0.015\%FS$
Load Regulation	Voltage ⁽²⁾	$\leq 0.005\% + 0.005\%FS$
	Current	$\leq 0.015\% + 0.015\%FS$
Isc	Current	21.0A
Input protection	OCP	15.3A
	OVP	61.2V
	OPP	510W
Input OVP	63V	
Remote Sense Compensation Voltage	$\leq 6V$	
Isolation DC to GND	800Vdc	
Working Temperature	0~40°C	
Storage Temperature	-10°C~70°C	
IP	IP20	
Cooling	Air	
Dimension (mm)	321mm(D)*104mm(W)*40.5mm(H)	

Weight(net)	1.0kg
--------------	-------

Note:

- (1) The voltage/current input is not less than 10%FS.
- (2) Under sense mode

IT27557

Model	IT27557 Programmable DC Load	
Rated value	Voltage	0.150V~150V
	Current	0~10A
	Power	0~500W
	Resistance	0.17Ω~1500Ω
	Min. operating voltage	1.7V at 10A
	Input leakage current	0.001A
Setup Resolution	Voltage	0.01V
	Current	0.001A
	Power	0.01W
	Resistance	0.01Ω
Read Back Resolution	Voltage	0.0001V
	Current	0.0001A
	Power	0.01W
Setup Accuracy	Voltage	≤0.02% + 0.02%FS
	Current	≤0.05% + 0.05%FS
	Power	≤0.1% + 0.2%FS
	Resistance ⁽¹⁾	(Vin/Rset)*0.5%+0.5%FS
Read Back Accuracy	Voltage	≤0.02% + 0.02%FS
	Current	≤0.05% + 0.05%FS
	Power	≤0.1% + 0.2%FS
Setup Temperature Coefficient	Voltage	≤20ppm/°C
	Current	≤30ppm/°C

Read Back Temperature Coefficient	Voltage	$\leq 20\text{ppm}/^{\circ}\text{C}$
	Current	$\leq 30\text{ppm}/^{\circ}\text{C}$
Current Slope	Rising slope	10A/ms
	Falling slope	10A/ms
Line Regulation	Voltage	$\leq 0.005\% + 0.005\%\text{FS}$
	Current	$\leq 0.015\% + 0.015\%\text{FS}$
Load Regulation	Voltage ⁽²⁾	$\leq 0.005\% + 0.005\%\text{FS}$
	Current	$\leq 0.015\% + 0.015\%\text{FS}$
Isc	Current	10.5A
Input protection	OCP	10.2A
	OVP	153V
	OPP	510W
	Input OVP	156V
Remote Sense Compensation Voltage		$\leq 15\text{V}$
Isolation DC to GND		800Vdc
Working Temperature		0~40°C
Storage Temperature		-10°C~70°C
IP		IP20
Cooling		Air
Dimension (mm)		321mm(D)*104mm(W)*40.5mm(H)
Weight(net)		1.0kg

Note:

- (1) The voltage/current input is not less than 10%FS.
- (2) Under sense mode



Connect with us

Thank you for purchasing ITECH products. Any questions, pls. feel free to let us know.



You can chat with us on ITECH website



For more information, pls. visit www.itechate.com



Click and follow ITECH Electronics

