



RIGOL

Electronic Calibration Module

Product Manual
2026.05



Guaranty and Declaration

Copyright

© 2026 RIGOL TECHNOLOGIES CO., LTD.

Trademark Information

RIGOL® is the trademark of RIGOL TECHNOLOGIES CO., LTD.

Publication Number

ADS02104-1110

Software Version

Software upgrade might change or add product features. Please acquire the latest version of the manual from **RIGOL** website or contact **RIGOL** to upgrade the software.

Notices

- RIGOL products are covered by P.R.C. and foreign patents, issued and pending.
- RIGOL reserves the right to modify or change parts of or all the specifications and pricing policies at the company's sole decision.
- Information in this publication replaces all previously released materials.
- Information in this publication is subject to change without notice.
- **RIGOL** shall not be liable for either incidental or consequential losses in connection with the furnishing, use, or performance of this manual, as well as any information contained.
- Any part of this document is forbidden to be copied, photocopied, or rearranged without prior written approval of **RIGOL**.

Product Certification

RIGOL guarantees that this product conforms to the national and industrial standards in China as well as the ISO9001:2015 standard and the ISO14001:2015 standard. Other international standard conformance certifications are in progress.

Contact Us

If you have any problem or requirement when using our products or this manual, please contact **RIGOL**.

E-mail: service@rigol.com

Website: www.rigol.com

Contents

Guaranty and Declaration.....	1
1 Safety Requirement	3
1.1 General Safety Summary	3
1.2 Safety Notices and Symbols.....	5
1.3 Working Environment.....	6
1.4 Operating and Safety Precautions.....	7
2 Product Overview	8
3 Document Overview.....	11
4 Quick Start	11
4.1 General Inspection	11
4.2 Appearance and Dimensions.....	12
4.3 Product dimensions	14
4.3.1 ECAL100 / ECAL 200 Series Two Port Electronic Calibrator Dimensions	14
4.3.1 ECAL100 / ECAL 200 Four Port Electronic Calibrator Dimensions	15
4.3.2 ECAL300 / ECAL 400 Series Electronic Calibrator Dimensions	15
4.4 When to Calibrate.....	16
5 Operation Guidance	16
5.1 To Connect and Disconnect the ECal Module.....	16
5.2 The status of the LED indicator	17
5.3 To Perform an Automatic Calibration	17
6 Technical Specifications	19
6.1 Performance Specifications	19
6.2 Mechanical Characteristics.....	21
7 Order Information.....	22

1 Safety Requirement

1.1 General Safety Summary

Please review the following safety precautions carefully before putting the instrument into operation so as to avoid any personal injury or damage to the instrument and any product connected to it. To prevent potential hazards, please follow the instructions specified in this manual to use the instrument properly.

Use Proper Power Cord.

Only the exclusive power cord designed for the instrument and authorized for use within the destination country could be used.

Ground the Instrument.

The instrument is grounded via the protective ground conductor in the power cable. To avoid electric shock, ensure that the ground terminal of the instrument's power cable is reliably connected to the protective ground before connecting any input or output terminals.

Observe All Terminal Ratings.

To avoid fire or shock hazard, observe all ratings and markers on the instrument and check your manual for more information about ratings before connecting the instrument.

Use Proper Overvoltage Protection.

Ensure that no overvoltage (such as that caused by a bolt of lightning) can reach the product. Otherwise, the operator might be exposed to the danger of an electric shock.

Do Not Operate Without Covers.

Do not operate the instrument with covers or panels removed.

Avoid Circuit or Wire Exposure.

Do not touch exposed junctions and components when the unit is powered on.

Do Not Operate With Suspected Failures.

If you suspect that any damage may occur to the instrument, have it inspected by **RIGOL** authorized personnel before further operations. Any maintenance, adjustment or replacement especially to circuits or accessories must be performed by **RIGOL** authorized personnel.

Provide Adequate Ventilation.

Inadequate ventilation may cause an increase of temperature in the instrument, which would cause damage to the instrument. So please keep the instrument well ventilated and inspect the air outlet and the fan regularly.

Do Not Operate in Wet Conditions.

To avoid short circuit inside the instrument or electric shock, never operate the instrument in a humid environment.

Do Not Operate in an Explosive Atmosphere.

To avoid personal injuries or damage to the instrument, never operate the instrument in an explosive atmosphere.

Keep Instrument Surfaces Clean and Dry.

To avoid dust or moisture from affecting the performance of the instrument, keep the surfaces of the instrument clean and dry.

Prevent Electrostatic Impact.

Operate the instrument in an electrostatic discharge protective environment to avoid damage induced by static discharges. Always ground both the internal and external conductors of cables to release static before making connections.

Handle with Caution.

Please handle with care during transportation to avoid damage to keys, knobs, interfaces, and other parts on the panels.

1.2 Safety Notices and Symbols

Safety Notices in this Manual:



WARNING

Indicates a potentially hazardous situation or practice which, if not avoided, will result in serious injury or death.



CAUTION

Indicates a potentially hazardous situation or practice which, if not avoided, could result in damage to the product or loss of important data.

Safety Notices on the Product:

DANGER It calls attention to an operation, if not correctly performed, could result in injury or hazard immediately.

WARNING It calls attention to an operation, if not correctly performed, could result in potential injury or hazard.

CAUTION It calls attention to an operation, if not correctly performed, could result in damage to the product or other devices connected to the product.

Safety Symbols on the Product:



Hazardous
Voltage



Safety
Warning



Protective
Earth Terminal



Chassis
Ground



Test Ground

1.3 Working Environment

Item	Condition	Description
Temperature Range	Operating	+15°C to +35°C
	Save	-20°C to 60°C
	Operating	Relative humidity (RH) up to 75%.
	Non-operating	85% at 65°C, 24 hours
Altitude	Operating:	below 2000 m



WARNING

In order to avoid short circuiting to the interior of the device or electric shock, please do not operate the instrument in a humid environment.

Installation (Overvoltage) Category

This product is powered by mains conforming to installation (overvoltage) category II.



WARNING

Ensure that no overvoltage (such as that caused by a bolt of lightning) can reach the product. Otherwise, the operator might be exposed to the danger of an electric shock.

Installation (Overvoltage) Category Definitions

Installation (overvoltage) category I refers to signal level which is applicable to equipment measurement terminals connected to the source circuit. Among these terminals, precautions are done to limit the transient voltage to a low level.

Installation (overvoltage) category II refers to the local power distribution level which is applicable to equipment connected to the AC line (AC power).

1.4 Operating and Safety Precautions

Observe the following guidelines before connecting or operating the Ecal module to ensure the instrument safety and measurement accuracy.

- **Warm up before calibration**

The electronic calibrator needs to be warmed up before calibration. After connecting the USB cable, the “Wait for” indicator lights red to warm up, allowing the internal temperature to reach a set constant temperature, and turns green when warm up is complete. This ensures consistency of the calibration state.

The warm-up time is related to the working ambient temperature, it is recommended that the working ambient temperature be kept between 20°C and 28°C. The two port electronic calibrator warm-up time is typically 15 to 20 minutes, and the four port electronic calibrator warm-up time is typically 20 to 25 minutes. If the ambient temperature is below 20°C, the warm-up period is extended accordingly.

- **ESD Protection**

Ecal module contains sensitive components. Static discharges can cause permanent damage to the unit. To prevent damage from ESD:

- Environment protection: place a grounded anti static mat in front of your test equipment and wear a grounded wrist strap attached to the mat when handling or operating the Ecal module. Wear a heel strap when working in an area with a conductive floor.
- Body grounding: ground yourself by grasping the grounded outer shell of the analyzer test port or cable connector briefly before you clean, inspect, or make a connection to an Ecal module.
- Physical protection: avoid touching the center conductor of the test ports to reduce the risk of electrostatic damage.

- **Connector Care**

Long-term use of the connector (interface > 500 mating cycles) will cause wear and tear failure, regular inspection and maintenance will extend life and guarantee measurement accuracy:

- Inspect the mating surface. Metal particles from connector threads often find their way onto the mating surface when a connection is made or disconnected.
- Cleaning Maintenance: Regular cleaning of the connector interface increases service life and improves calibration and measurement quality.
- Gage connectors periodically. Regularly calibrate the connectors for accuracy, verify the mechanical tolerances and connector performance to detect potential damage risks in advance.

- **Torque Operation**

**CAUTION**

ECal modules can be damaged if you apply excessive torque to the connectors.

2 Product Overview

RIGOL produces electronic calibrators in a variety of models covering the frequency bands DC/100 kHz to 26.5 GHz, RF connectors in the form of 3.5mm, SMA and Type-N, using a USB interface for communication and power supply. The electronic calibration module is applicable to calibrate and correct errors for vector network analyzers from RIGOL.

- Coverage band range: DC/100kHz to 26.5 GHz
- Maximum port capacity: +10 dBm
- Calibration input power: -5 dBm MAX.
- Maximum Protected DC Voltage:
 - ±10 VDC for (AC Coupled) ECAL100 Series/ECAL300 Series
 - 0 VDC for (DC Coupled) ECAL200 Series/ECAL400 Series
- RF connector types: 3.5 mm female, Type-N 50Ω female, SMA female
(Custom optional double male or male female connector type)
- Number of ports supported: 2/4
- Power supply: USB 2.0

Electronic calibration parts (ECal) offer easy operation, higher efficiency and greater reliability than mechanical calibrations. Calibration is done with fewer connections, such as a four-port calibration with a four-port electronic calibration, which requires only a single connection, significantly reducing the risk of human error and cable loss due to repeated swapping. The same calibration accuracy is maintained. The ECal module supports multiple connector types and cover most applications of mechanical kits, especially in high-frequency or multi-port testing. The ECal module can avoid instability introduced by repeated connections and significantly improving calibration efficiency and test reliability.

Electronic calibration part number

ECAL100 Series

Model	Frequency Range	No. of Ports	Description
ECAL109-NF2	100 kHz to 9 GHz	2	Type-N (F) 50 Ω
ECAL114-NF2	100 kHz to 14 GHz	2	Type-N (F) 50 Ω
ECAL126-35F2	100 kHz to 26.5 GHz	2	3.5 mm (F)
ECAL109-NF4	100 kHz to 9 GHz	4	Type-N (F) 50 Ω
ECAL114-NF4	100 kHz to 14 GHz	4	Type-N (F) 50 Ω
ECAL126-35F4	100 kHz to 26.5 GHz	4	3.5 mm (F)

ECAL200 Series

Model	Frequency Range	No. of Ports	Description
ECAL209-NF2	DC to 9 GHz	2	Type-N (F) 50 Ω
ECAL214-NF2	DC to 14 GHz	2	Type-N (F) 50 Ω
ECAL226-35F2	DC to 26.5 GHz	2	3.5 mm (F)
ECAL209-NF4	DC to 9 GHz	4	Type-N (F) 50 Ω
ECAL214-NF4	DC to 14 GHz	4	Type-N (F) 50 Ω
ECAL226-35F4	DC to 26.5 GHz	4	3.5 mm (F)

ECAL300 Series

Model	Frequency Range	No. of Ports	Description
-------	-----------------	--------------	-------------

ECAL304-NF2	100 kHz to 4.5 GHz	2	Type-N (F) 50 Ω
ECAL309-NF2	100 kHz to 9 GHz	2	Type-N (F) 50 Ω
ECAL314-NF2	100 kHz to 14 GHz	2	Type-N (F) 50 Ω
ECAL304-SF2	100 kHz to 4.5 GHz	2	Type SMA (female)
ECAL309-SF2	100 kHz to 9 GHz	2	Type SMA (female)
ECAL314-SF2	100 kHz to 14 GHz	2	Type SMA (female)

ECAL400 Series

Model	Frequency Range	No. of Ports	Description
ECAL404-NF2	DC to 4.5 GHz	2	Type-N (F) 50 Ω
ECAL409-NF2	DC to 9 GHz	2	Type-N (F) 50 Ω
ECAL414-NF2	DC to 14 GHz	2	Type-N (F) 50 Ω
ECAL404-SF2	DC to 4.5 GHz	2	Type SMA (female)
ECAL409-SF2	DC to 9 GHz	2	Type SMA (female)
ECAL414-SF2	DC to 14 GHz	2	Type SMA (female)

3 Document Overview

This manual introduces the appearance of electronic calibration module, its operating methods, and specifications for each model. Electronic calibration module (ECal module) is a high accuracy, single connection calibration technology that employs traceable and verifiable electronic standards. Each module contains unique - parameter data that is used to calculate error terms for vector network analyzers during calibration.

ECal module is applicable to calibrate and correct errors for vector network analyzers from RIGOL. You can download the latest manual for the desired Vector Network Analyzer from RIGOL official website (www.rigol.com).

4 Quick Start

4.1 General Inspection

1 Inspect the packaging

If the packaging has been damaged, do not dispose the damaged packaging or cushioning materials until the shipment has been checked for completeness and has passed both electrical and mechanical tests.

The consigner or carrier shall be liable for the damage to the instrument resulting from shipment. RIGOL would not be responsible for free maintenance/rework or replacement of the instrument.

2 Inspect the instrument

In case of any mechanical damage, missing parts, or failure in passing the electrical and mechanical tests, contact your RIGOL sales representative.

3 Check the accessories

Please check the accessories according to the packing lists. If the accessories are damaged or incomplete, please contact your RIGOL sales representative.

4 Recommended Calibration Interval

RIGOL recommends a 12-month calibration period.

4.2 Appearance and Dimensions

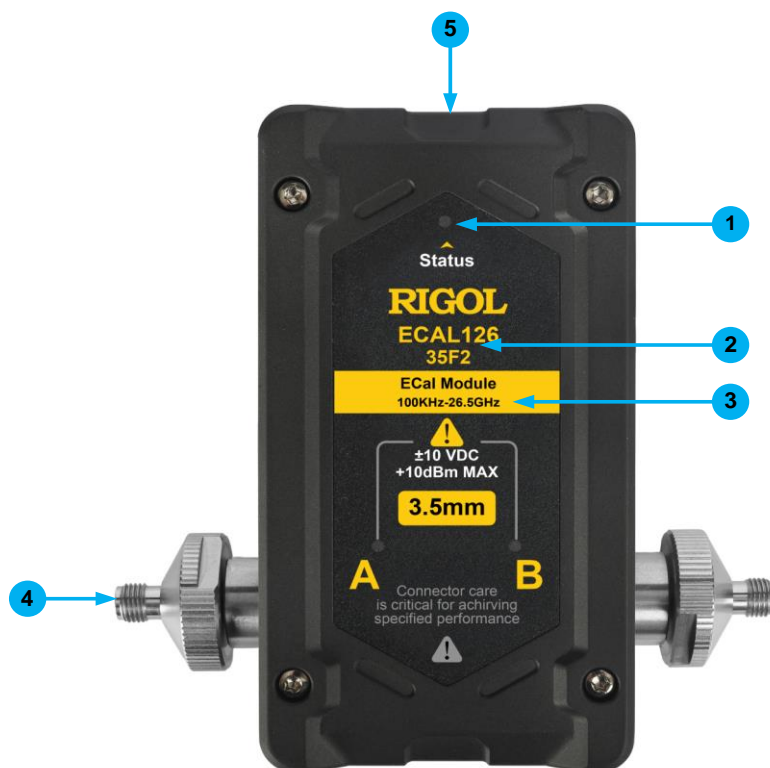

Two port 3.5 mm (female) connector

Number	Description
1	Status LED
2	Model
3	Operating frequency range
4	Calibration Port
5	USB Port



ECAL100 Series

Four port 3.5 mm (female) connector



ECAL200 Series

Four-port N-type (female) connector



ECAL300 Series

Two-port type N (female) connector



ECAL400 Series

Two-port SMA type (female) connector

4.3 Product dimensions

4.3.1 ECAL100 / ECAL 200 Series Two Port Electronic Calibrator Dimensions

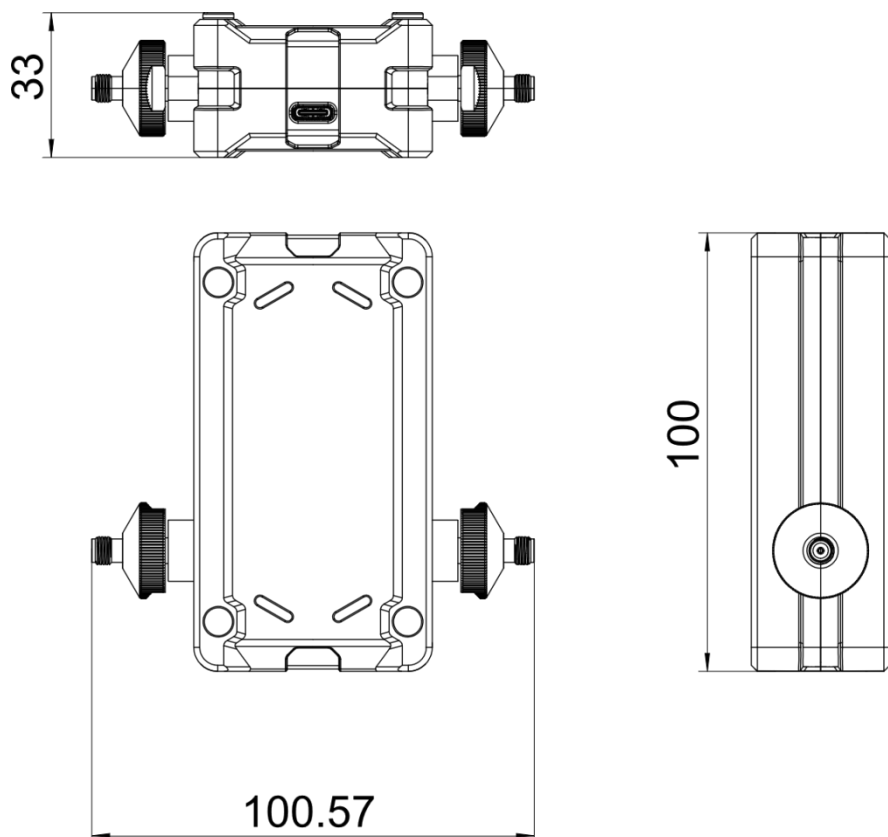

Unit: mm

4.3.1 ECAL100 / ECAL 200 Four Port Electronic Calibrator Dimensions

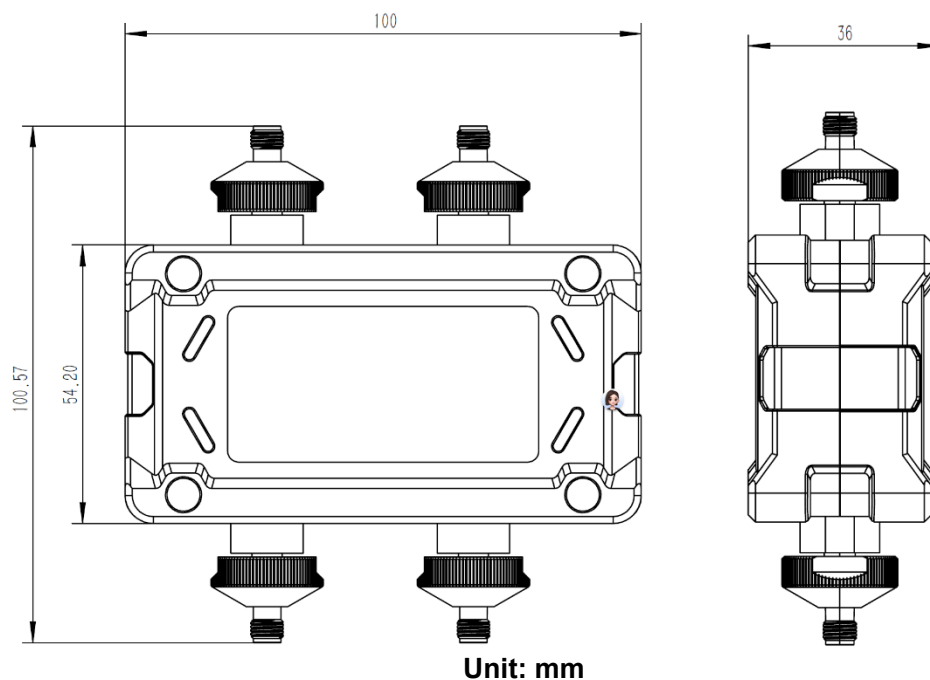

4.3.2 ECAL300 / ECAL 400 Series Electronic Calibrator Dimensions

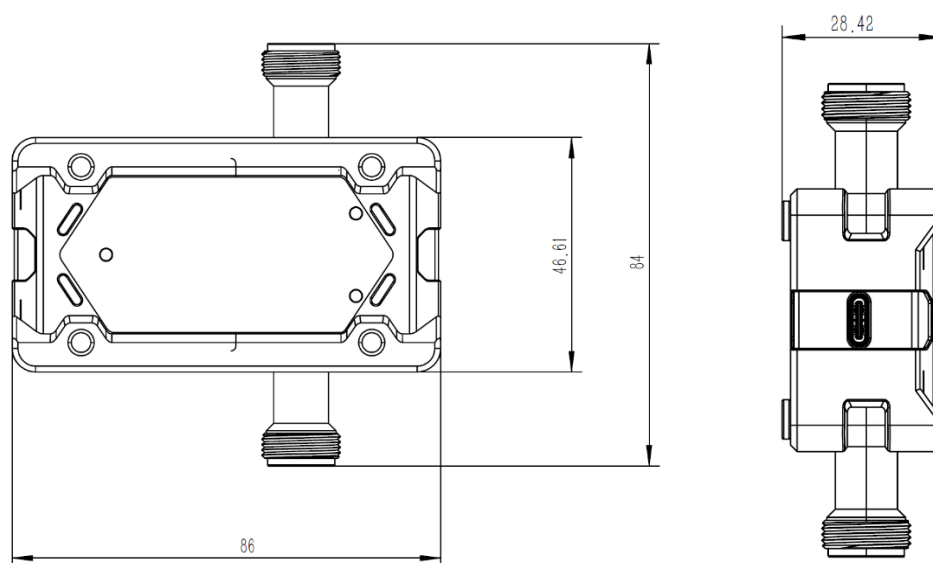

Unit: mm

4.4 When to Calibrate

- Calibration is required when changes in system error are not negligible (uncorrected leakages, mismatches, system frequency response changes $\geq 10\%$ relative to accuracy specifications).
- Calibration is required when a significant environmental change (especially in temperature) occurs between calibration and measurement. The temperature change can alter the physical length of internal and external cables and affect accuracy.
- Calibration is required when the test port connectors and calibration standards become dirty or damaged. If the connectors become dirty or damaged, measurement repeatability and accuracy is affected.
- Calibration is required when the re-measurement calibration standard does not produce repeatable results. You should maintain the test port connector, cable and calibration standards before performing the calibration.
- Periodically remeasure the devices under test or the known devices. Calibration is required when any changes in its corrected response which can be attributed to the test system.

5 Operation Guidance

5.1 To Connect and Disconnect the ECal Module

- Connect the ECal module to any of the USB Type-A connectors on the front or rear panel of the vector network analyzer via USB Type-A connector (USB Type-C to Type-A connector) of the USB cable. The vector network analyzer can be controlled or powered via a USB cable.
- When connecting an Ecal module to a vector network analyzer, the vector network analyzer automatically identifies the type of calibration module, frequency range, and connector type.

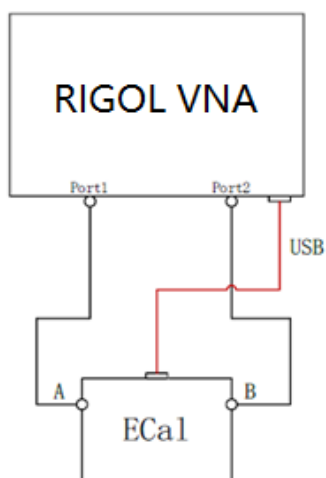

5.2 The status of the LED indicator

Status LED Color	Description
Off	The calibration piece is not properly connected to the instrument that needs to be calibrated
Steady Red	During warm-up, during start-up (refer to 1.4 chapter for warm-up time)
Steady Green	After warm-up, the ECal module is connected, functional, and ready for use.
Alternating Red/Green Flashing	ECal module is too hot or too cold and unable to regulate internal temperature to setpoint.

5.3 To Perform an Automatic Calibration

For all calibration types, complete the following steps:

1. Connect the ECal module to VNA with a matching frequency range and connector type, including the interface under test and the USB power connector, and wait until the LED turns green.

The warm-up time is related to the working ambient temperature, it is recommended that the working ambient temperature be kept between 20°C and 28°C. The two port electronic calibrator warm-up time is typically 15 to 20 minutes,

and the four port electronic calibrator warm-up time is typically 20 to 25 minutes. If the ambient temperature is below 20°C, the warm-up period is extended accordingly.

2. Configure VNA excitation source parameters, including frequency range of transmitted signals, output power, number of scans, and more. View the response (uncorrected) and optimize the vector network analyzer settings as needed.
3. On the VNA, click or tap Calibration > Main > ECal to enter the following menu.



4. Select "Cal Type" and "Port ECal Configuration" as needed. Click or tap Next to enter the "Electronic Calibration Step" menu, as shown in the figure below.



5. As prompted, click or tap Measure to complete the calibration and save the calibration information.



6. When the calibration is complete, remove the ECal module, and connect the DUT. The calibrated measurements are then performed.



CAUTION

ECal modules can be damaged if you apply excessive torque to the connectors.

Tip: For optimal results, terminate any unused ECal ports with a 50 Ω load.

6 Technical Specifications

6.1 Performance Specifications

The ECAL100 / ECAL200 2-port series of calibrated system performance

Frequency Range	DC to 10 MHz	100 kHz to 10 MHz	10 MHz to 4.5 GHz	4.5 GHz to 9 GHz	9 GHz to 14 GHz	14 GHz to 26.5 GHz
Directivity (dB)	48	48	45	45	40	40
Source Match (dB)	35	35	30	30	28	26
Load Matching (dB)	45	45	40	40	35	35
Reflectance tracking (\pm dB)	0.1	0.1	0.12	0.16	0.22	0.32
Transfer tracking (\pm dB)	0.06	0.06	0.1	0.15	0.18	0.3

[1] The measurement data is calibrated by RIGOL DNA6264 vector network analyzer.

[2] ECAL200 series only, support DC - 10 MHz frequency range

The ECAL100 / ECAL200 Quad Port Series Calibrated System Performance

Frequency Range	DC to 10 MHz	100 kHz to 10 MHz	10 MHz to 4.5 GHz	4.5 GHz to 9 GHz	9 GHz to 14 GHz	14 GHz to 26.5 GHz
Directivity (dB)	48	48	48	45	40	40
Source Match (dB)	35	35	30	30	28	26
Load Matching (dB)	45	45	45	40	35	35
Reflectance tracking	0.1	0.1	0.12	0.16	0.22	0.32

(±dB)						
Transfer tracking (±dB)	0.1	0.1	0.12	0.18	0.24	0.38

[1] The measurement data is calibrated by RIGOL DNA6264 vector network analyzer.

[2] ECAL200 series only, support DC - 10 MHz frequency range

The ECAL300 / ECAL400 series of calibrated system performance

Frequency Range	DC to 10 MHz	100 kHz to 10 MHz	10 MHz to 4.5 GHz	4.5 GHz to 9 GHz	9 GHz to 14 GHz
Directivity (dB)	40	40	38	36	36
Source Match (dB)	30	30	30	28	28
Load Matching (dB)	35	35	32	30	28
Reflectance tracking (±dB)	0.13	0.13	0.18	0.25	0.25
Transfer tracking (±dB)	0.15	0.15	0.2	0.22	0.3

[1] The measurement data is calibrated by RIGOL DNA814 vector network analyzer.

[2] ECAL400 series only, support DC - 10 MHz frequency range

Ecal Module Specifications

Item	Description
Maximum Calibration Input Power	-5 dBm
Maximum Port Power	+10 dBm
Control Port Type	USB
Operating Voltage	DC +5 V 500 mA

6.2 Mechanical Characteristics

Item	Description
Dimensions (W x H x D)	<ul style="list-style-type: none">● ECAL100 / ECAL200 Series Two-port version: 100 mm x 100.57 mm x 33 mm Four port version: 100 mm x 100.57 mm x 36 mm● ECAL300 / ECAL400 Series 86 mm x 84 mm x 28.42 mm
Weight	<ul style="list-style-type: none">● ECAL100 / ECAL200 Series Two-port model: 350g (without packaging) Quad port model: 450g (without packaging)● ECAL300 / ECAL400 Series 180g (package not included)

7 Order Information

	Description	Order No.
ECAL100 Series Ecal Module	100 kHz to 9 GHz, 2 Port, Type N (female head) 50 Ω	ECAL109-NF2
	100 kHz to 14 GHz, 2-Port, Type-N (female) 50 Ω	ECAL114-NF2
	100 kHz to 26.5 GHz, 2-Port, 3.5 mm (female)	ECAL126-35F2
	100 kHz to 9 GHz, 4-Port, Type-N (female) 50 Ω	ECAL109-NF4
	100 kHz to 14 GHz, 4-Port, Type-N (female) 50 Ω	ECAL114-NF4
	100 kHz to 26.5 GHz, 4-Port, 3.5 mm (female)	ECAL126-35F4
ECAL200 Series Ecal Module	DC to 9 GHz, 2 Port, Type N (female) 50 Ω	ECAL209-NF2
	DC to 14 GHz, 2 Port, Type N (female) 50 Ω	ECAL214-NF2
	DC to 26.5 GHz, 2 Port, 3.5 mm (female)	ECAL226-35F2
	DC to 9 GHz, 4 Port, Type N (female) 50 Ω	ECAL209-NF4
	DC to 14 GHz, 4 Port, Type N (female) 50 Ω	ECAL214-NF4
	DC to 26.5 GHz, 4 Port, 3.5 mm (female)	ECAL226-35F4
ECAL300 Series Ecal Module	100 kHz to 4.5 GHz, 2 Port, Type N (female head) 50 Ω	ECAL304-NF2
	100 kHz to 9 GHz, 2 Port, Type N (female head) 50 Ω	ECAL309-NF2
	100 kHz to 14 GHz, 2-Port, Type-N (female) 50 Ω	ECAL314-NF2
	100 kHz to 4.5 GHz, 2 Port, SMA mm (female)	ECAL304-SF2
	100 kHz to 9 GHz, 2 Port, SMA mm (female)	ECAL309-SF2
	100 kHz to 14 GHz, 2 Port, SMA mm (female)	ECAL314-SF2
ECAL400 Series Ecal	DC to 4.5 GHz, 2 Port, Type N (female) 50 Ω	ECAL404-NF2
	DC to 9 GHz, 2 Port, Type N (female) 50 Ω	ECAL409-NF2

Module	DC to 14 GHz, 2 Port, Type N (female) 50Ω	ECAL414-NF2
	DC to 4.5 GHz, 2 Port, SMA mm (female)	ECAL404-SF2
	DC to 9 GHz, 2 Port, SMA mm (female)	ECAL409-SF2
	DC to 14 GHz, 2 Port, SMA mm (female)	ECAL414-SF2
Standard Accessories	USB2.0 Cable	-
Optional Accessories	Torque wrench, 8 in-lb, 8.1 mm, open-ended, for SMA 3.5 mm connector	TW8-8
	Torque wrench, 12 in-lb, 19.1 mm, open-ended, for Type-N connector	TW812-19

Boost Smart World and Technology Innovation

Industrial Intelligent
Manufacturing



Semiconductors



Education &
Research



Communication

System Integration



New Energy



- Cellular-5G/WIFI
- UWB/RFID/ ZIGBEE
- Digital Bus/Ethernet
- Optical Communication

- Digital/Analog/RF Chip
- Memory and MCU Chip
- Third-Generation Semiconductor
- Solar Photovoltaic Cells

- New Energy Automobile
- PV/Inverter
- Power Test
- Automotive Electronics

*Provide Testing and Measuring Products
and Solutions for Industry Customers*

HEADQUARTER

RIGOL TECHNOLOGIES CO., LTD.
No.8 Keling Road, New District,
Suzhou, JiangSu, P.R.China
Tel: +86-400620002
Email: info-cn@rigol.com

JAPAN

RIGOL JAPAN CO., LTD.
5F, 3-45-6, Minamiotsuka, Toshima-Ku,
Tokyo, 170-0005, Japan
Tel: +81-3-6262-8932
Fax: +81-3-6262-8933
Email: info.jp@rigol.com

EUROPE

RIGOL TECHNOLOGIES EU GmbH
Friedrichshafener Str. 5
82205 Gilching
Germany
Tel: +49(0)8105-27292-21
Email: info-europe@rigol.com

KOREA

RIGOL KOREA CO., LTD.
5F, 222, Gonghang-daero,
Gangseo-gu, Seoul, Republic of Korea
Tel: +82-2-6953-4466
Fax: +82-2-6953-4422
Email: info.kr@rigol.com

NORTH AMERICA

RIGOL TECHNOLOGIES, USA INC.
10220 SW Nimbus Ave.
Suite K-7
Portland, OR 97223
Tel: +1-877-4-**RIGOL**-1
Email: sales@rigol.com

For Assistance in Other Countries

Email: info.int@rigol.com

RIGOL® is the trademark of **RIGOL TECHNOLOGIES CO., LTD.** Product information in this document is subject to update without notice. For the latest information about **RIGOL**'s products, applications and services, please contact local **RIGOL** channel partners or access **RIGOL** official website: www.rigol.com