

## SAUTER service guarantee

“We at SAUTER are only satisfied when we’ve found the very best solution for you. After all, our heritage from the Swabian Jura Mountains and the famous inventive talent of the people that live here, means we have an exceptional reputation to maintain.”

Printed in Germany  
by SAUTER GmbH  
z-cs-gb-sp-20161

GB



## SAUTER Models A – Z

287/289 _____	6	SU _____	64
AFH-FAST _____	24	TB _____	39
AFH-FD _____	25	TB-US _____	45
DA _____	32	TC _____	40
DB _____	33	TD-GOLD _____	47
FA _____	7	TD-US _____	46
FC _____	9	TE _____	41
FH-M _____	11	TF _____	42
FH-S _____	10	TG _____	42
FK _____	8	THM _____	18
FL _____	12	TI _____	54
FP-M _____	14	TJ _____	43
FP-S _____	13	TN-EE _____	49
HB _____	52	TN-US _____	48
HD _____	53	TPE _____	17
HK _____	56	TU-US _____	50
HK-D _____	56	TVL _____	15
HMM _____	57	TVM-NL _____	21
HMO _____	58	TVO _____	19
HN-D _____	59	TVO-S _____	20
HO _____	61	TVP _____	16
LB _____	36	TVP-L _____	16
SD-M _____	23	TVS _____	22
SO _____	63		

## MEASURING TECHNOLOGY

Force measurement, Coating thickness measurement, Hardness measurement, Material thickness measurement, Occupational safety, Calibration service



## Keyword index

Coating thickness gauge, digital _____	39-42
Force gauge, digital _____	8-14
Force gauge, mechanical _____	7
Hardness tester, digital _____	53, 56-59, 61
Hardness tester, Leeb _____	55-59
Hardness tester, Shore _____	51-54
Hardness testing, (UCI) _____	60-61
Impact type sensor _____	56-59
Integrated calliper gauge, digital _____	35-37
Leeb hardness tester, digital _____	55-59
Length meter, digital _____	35-37
Light measuring instrument _____	63
Material thickness gauge, ultrasonic _____	45-46, 48-49
Measuring head, external _____	39, 41/42, 45-50, 56-58
Occupational safety _____	62-64
Printer _____	48, 50
Shore hardness tester, analogue _____	52
Software _____	24/25
Sound level meter _____	64
Spring balances _____	6
Spring tester _____	23
Test stand, Coating Thickness-, manual _____	43
Test stand, force-, motorised _____	18-23
Test stand, force-, manual _____	54
Test stand, Shore-, manual _____	15-17
Torque gauges _____	31-33
Wall thickness gauge _____	44-50

## Force measurement accessories from page 26

1-jaw-clamp _____	26	Roller tension clamps _____	27
2 wide jaw grip _____	26	Rolling-clamp _____	26
3-point bending device _____	28, 29	Rope and thread tension clamps _____	27
Angle bracket _____	26	Screw tension clamp _____	26
Attachments _____	29	Sensor _____	28
Ball-shaped head, stainless steel _____	28	Tensiometer attachment _____	29
Belt tension clamps _____	28	Thin film grip _____	26
Bending attachment _____	28	Tombstone tester _____	29
Cable fixture _____	26	Wedge tension clamp _____	27
Carrying strap _____	29	Wide jaw clamp _____	26
Door tester _____	29		
Drum clamps _____	26		
Fine point clamp _____	26		
Flat clamp _____	26		
Grip clamp _____	26		
Handle bar, stainless steel _____	29		
Interface cables _____	29		
Long clamp _____	26		
Parallel jaw grip _____	26		
Pressure disc _____	28		
Quick clamp _____	27		
Relais module _____	29		
Ring fixture _____	26		
Roll clamps, eccentric _____	26		

### fast

- 24 hours delivery service – order today, on its way tomorrow
- Sales & service hotline from 8:00 am to 6:00 pm

### reliable

- 2 years warranty

### diverse

- One-stop-shopping: from force gauges up to light measuring instruments – everything from one supplier
- Quick as a flash, find the product you want with the „Measuring instruments Quick-Finder“ at [www.sauter.eu](http://www.sauter.eu)

**Order hotline**  
+49 [0] 7433 9933-0

**Online-Shop**  
[www.sauter.eu](http://www.sauter.eu)

**Our team of consultants will assist you**  
from Monday to Friday  
from 8:00 am to 6:00 pm  
von 8:00 – 18:00 Uhr

**Service hotline**  
+49 [0] 7433 9933-199

**E-mail order**  
[info@sauter.eu](mailto:info@sauter.eu)

**www.sauter.eu**  
For product data sheets, user manuals, useful information, technical glossary, pictures and much more, as well as a smart search engine for measuring instruments

**Fax order**  
+49 [0] 7433 9933-146



Sauter GmbH  
c/o KERN & SOHN GmbH  
Ziegelei 1  
72336 Balingen  
Germany

Tel. +49 [0] 7433 9933-0  
Fax +49 [0] 7433 9933-149

[info@sauter.eu](mailto:info@sauter.eu)  
[www.sauter.eu](http://www.sauter.eu)

PROFESSIONAL MEASURING

2016

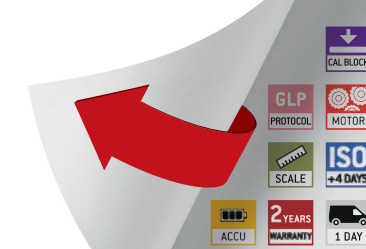



## SAUTER Piktogramme

- CAL EXT** **Adjusting program (CAL):**  
For quick setting of the balance's accuracy. External adjusting weight required.
- CAL BLOCK** **Calibration block:**  
standard for adjusting or correcting the measuring device.
- PEAK** **Peak hold function:**  
capturing a peak value within a measuring process.
- SCAN** **Scan mode:**  
continuous capture and display of measurements.
- PUSH/PULL** **Push and Pull:**  
the measuring device can capture tension and compression forces.
- SCALE** **Length measurement:**  
captures the geometric dimensions of a test object or the movement during a test process.
- FOCUS** **Focus function:**  
increases the measuring accuracy of a device within a defined measuring range.
- MEMORY** **Internal memory:**  
to save measurements in the device memory.
- RS 232** **Data interface RS-232:**  
bidirectional, for connection of printer and PC.
- USB** **Data interface USB:**  
To connect the measuring instrument to a printer, PC or other peripheral devices.
- IR** **Data interface Infrared:**  
To transfer data from the measuring instrument to a printer, PC or other peripheral devices.
- SWITCH** **Control outputs (optocoupler, digital I/O):**  
to connect relays, signal lamps, valves, etc.
- ANALOG** **Analogue interface:**  
to connect a suitable peripheral device for analogue processing of the measurements
- STATISTIC** **Statistics:**  
using the saved values, the device calculates statistical data, such as average value, standard deviation etc.
- SOFTWARE** **PC Software:**  
to transfer the measurements from the device to a PC.
- PRINT** **Printer:**  
a printer can be connected to the device to print out the measurements.
- GLP PROTOCOL** **GLP/ISO record keeping:**  
of measurements with date, time and serial number. Only with SAUTER printers
- UNIT** **Measuring units:**  
Weighing units can be switched to e.g. non-metric at the touch of a key. Please refer to website for more details.
- TOL** **Measuring with tolerance range:**  
Upper and lower limiting can be programmed individually
- ZERO** **ZERO:**  
Resets the display to „0“.
- BATT** **Battery operation:**  
Ready for battery operation. The battery type is specified for each device.
- ACCU** **Rechargeable battery pack:**  
rechargeable set.
- 230 V** **Mains adapter:**  
230V/50Hz in standard version for EU. On request GB, AUS or USA version available.
- 230 V** **Power supply:**  
Integrated, 230V/50Hz in EU. More standards e.g. GB, AUS or USA on request
- MOTOR** **Motorised drive:**  
The mechanical movement is carried out by a motorised drive.
- FASTMOVE** **Fast-Move:**  
the total length of travel can be covered by a single lever movement.
- ISO +4 DAYS** **ISO Calibration:**  
The time required for ISO calibration is shown in days in the pictogram.
- 1 DAY** **Package shipment:**  
The time required for internal shipping preparations is shown in days in the pictogram.
- 1 DAY** **Pallet shipment:**  
The time required for internal shipping preparations is shown in days in the pictogram.
- 2 YEARS WARRANTY** **Warranty:**  
The warranty period is shown in the pictogram.

## Testing services, measuring technology and microscopy from a single source



SAUTER measuring equipment catalogue

Balances & Test service catalogue

Microscopes & refractometers catalogue

Medical scales catalogue

KERN DAkkS calibration service brochure

## SAUTER – A heritage of precision

Dear customer,

for over seven generations my family has been leading the way in the precision measuring instruments' industry. Today more than ever before, there is a need for most precise measurement.

We're also passionate about offering you products of highest possible quality, at most affordable prices.

That's why we not only offer a comprehensive range of universal standard products, but also design bespoke solutions to fit your unique needs.

Take a look through our catalogue. If you have any queries or feedback, do not hesitate to call me or any of my colleagues. We'll be happy to help you.

SAUTER – Professional measuring equipment tailored to the requirements in practice

Yours Albert Sauter, Managing director

P.S.  
For a wide variety of scales and weights please visit the website of our partner company **KERN & SOHN GmbH** or have a look through the product offering on page 55 in this catalogue. KERN & SOHN is a leading provider in this industry. You'll find it at: [www.kern-sohn.com](http://www.kern-sohn.com)



## Your advantages

- 1 Quick Delivery**  
Items in stock are sent the same day if orders are placed before 1:00 pm (valid for parcel service delivery within the EC).
- 2 Price performance ratio**  
SAUTER measuring instruments are always an inexpensive alternative. They are durable, uncomplicated and easy to put into operation.
- 3 Direct dispatch**  
of ordered goods to your customer is available, with personalised delivery note if desired (please ask), with invoice issued to you (third party business).
- 4 2 years warranty**
- 5 You have no storage costs –**  
we maintain the storage.
- 6 Sale or return**  
within 14 days of purchase.

# NEWS

We also have lots of new models in our range for 2016. Innovative products in the usual KERN quality:

### School balance KERN EMB-S

The space miracle - stackable school balance for experiment-based teaching



from € 200,- (pack of 5)

### Precision balances PNS · PNJ

The new standard in the laboratory with robust tuning fork weighing system



from € 570,-

### Analytical balance KERN ADB

The price leader in analytical balances

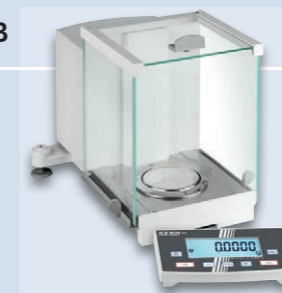

only € 910,-

### Moisture analyser DAB

Moisture analyser with user-friendly graphics display and 15 memories for drying programs



only € 1130,-

### Moisture analyser MLS-D

Infrared moisture analyzer with graphics display and a vast database



only € 1450,-

### Premium counting system CCP

Premium counting system for high-capacity counting applications with the highest level of accuracy, counting resolution up to 6 million points



from € 2600,-

### Premium counting system CCT

Premium counting system with EC type approval [M], for complex counting applications with the highest level of accuracy, counting resolution up to 6 million points



from € 2700,-

### Pallet scale UFC

Pallet scale with steel load support (IP67) and stainless steel display device (IP65), with EC type approval [M]



only € 1280,-

### Crane scales HFO

Industrial crane scale up to 6 t – with EC type approval [M]



from € 1020,-









### Thermal label printer YKE-01

Cost-effective universal label printer for KERN balances



only € 590,-

# Product group index 2016

<p>Force measurement - Accessories</p>	 <p>250 N</p>	<p>5 – 30</p>	<p>01</p>
<p>Torque measurement - Test weights</p>	 <p>0,15 Nm</p>	<p>31 – 34</p>	<p>02</p>
<p>Length measurement</p>	 <p>360 mm</p>	<p>35 – 37</p>	<p>03</p>
<p>Coating thickness measurement</p>	 <p>11 µm</p>	<p>38 – 43</p>	<p>04</p>
<p>Wall thickness measurement</p>	 <p>30 mm</p>	<p>44 – 50</p>	<p>05</p>
<p>Hardness testing of plastics (Shore)</p>	 <p>HX 100</p>	<p>51 – 54</p>	<p>06</p>
<p>Hardness testing of metals (Leeb)</p>	 <p>HLD 223</p>	<p>55 – 59</p>	<p>07</p>
<p>Hardness testing of metals (VCI)</p>	 <p>HV 225</p>	<p>60 – 61</p>	<p>08</p>
<p>Occupational safety/Environment</p>	 <p>db 42</p>	<p>62 – 64</p>	<p>09</p>
<p>Calibration service</p>		<p>65</p>	

Do you have questions about our products?  
Our customer consultants will be pleased to assist you:

#### UK, IE, MT, Scandinavia



**Marietta Diener**

Tel. +49 [0] 7433 9933-167  
Fax +49 [0] 7433 9933-29167  
Mobil +49 [0] 151 46143236  
diener@kern-sohn.com

#### USA, CAN, TR, Middle East, Africa, Oceania, South East Asia



**Corinna Klaass**

Tel. +49 [0] 7433 9933-215  
Fax +49 [0] 7433 9933-29215  
corinna.klaass@kern-sohn.com

#### PT, SLO, HR, BA, RS, MK, BeNeLux



**Taras Mikitisin**

Tel. +49 [0] 7433 9933-143  
Fax +49 [0] 7433 9933-29143  
Mobil +49 [0] 171 5590115  
mikitisin@kern-sohn.com

#### CZ, SK, DE (Zip Code 4, 5, 6)



**Katharina Queitsch**

Tel. +49 [0] 7433 9933-218  
Fax +49 [0] 7433 9933-29218  
Mobil +49 [0] 151 46142894  
katharina.queitsch@kern-sohn.com

#### BG, HU, PL, RO



**Fabienne Kolbus**

Tel. +49 [0] 7433 9933-305  
Fax +49 [0] 7433 9933-29305  
fabienne.kolbus@kern-sohn.com

#### GUS, EE, LT, LV



**Inna Wandler**

Tel. +49 [0] 7433 9933-167  
Fax +49 [0] 7433 9933-29167  
wandler@kern-sohn.com

#### General Management



**Albert Sauter**

Tel. +49 [0] 7433 9933-157  
Fax +49 [0] 7433 9933-29157  
albert-sauter@kern-sohn.com

#### Sales Management



**Ulrich Ulmer**

Tel. +49 [0] 7433 9933-160  
Fax +49 [0] 7433 9933-29160  
Mobil +49 [0] 172 7423944  
ulmer@kern-sohn.com

#### Marketing Management



**Thomas Fimpel**

Tel. +49 [0] 7433 9933-130  
Fax +49 [0] 7433 9933-29130  
fimpel@kern-sohn.com

#### Technical Service



**Stefan Rothmund**

Tel. +49 [0] 7433 9933-179  
Fax +49 [0] 7433 9933-195  
rothmund@kern-sohn.com

#### DAkS Calibration Service



IE, GB, DK, America,  
DE (Zip Code 3, 4)

**Katharina Faradacco**

Tel. +49 [0] 7433 9933-123  
Fax +49 [0] 7433 9933-29123  
katharina.faradacco@kern-sohn.com

#### Accountancy



**Jutta Osswald**

Tel. +49 [0] 7433 9933-159  
Fax +49 [0] 7433 9933-149  
jutta.osswald@kern-sohn.com



# 250 N



## 01 Force measurement



**Irmgard Russo**

Product specialist Force measurement

Tel. +49 [0] 7433 9933-208

Fax +49 [0] 7433 9933-29208

russo@kern-sohn.com

### Quick-Finder

Readout [d] N	Measuring range [Max] N	Model  SAUTER	Price excl. VAT, ex works €	Page
0,001	2	FH 2.	460,-	10
0,001	2	FP 2	990,-	13
0,001	5	FH 5.	460,-	10
0,001	5	FP 5	990,-	13
0,002	5	FL 5	500,-	12
0,005	10	FK 10.	250,-	8
0,005	10	FH 10.	460,-	10
0,005	10	FL 10	500,-	12
0,005	10	FP 10	990,-	13
0,01	1	289-100	75,-	6
0,01	10	FC 10	370,-	9
0,01	20	FH 20.	460,-	10
0,01	20	FP 20	990,-	13
0,01	25	FL 20	500,-	12
0,01	25	FK 25.	250,-	8
0,01	50	FC 50	370,-	9
0,01	50	FH 50.	460,-	10
0,01	50	FP 50	990,-	13
0,01	50	SD 50N100.	1640,-	23
0,02	50	FK 50.	250,-	8
0,02	50	FL 50	500,-	12
0,02	100	SD 100N100.	1640,-	23
0,05	5	289-102	75,-	6
0,05	10	FA 10.	210,-	7
0,05	100	FH 100.	460,-	10
0,05	100	FK 100.	250,-	8
0,05	100	FL 100	500,-	12
0,05	100	FP 100	990,-	13
0,05	200	SD 200N100.	1640,-	23
0,1	10	289-104	85,-	6
0,1	20	FA 20.	210,-	7
0,1	100	FC 100	370,-	9
0,1	200	FP 200	990,-	13

Readout [d] N	Measuring range [Max] N	Model  SAUTER	Price excl. VAT, ex works €	Page
0,1	200	FH 200.	460,-	10
0,1	250	FK 250.	250,-	8
0,1	250	FL 200	500,-	12
0,1	300	SD 300N100.	1640,-	23
0,1	500	FC 500	370,-	9
0,1	500	FH 500.	460,-	10
0,1	500	FP 500	990,-	13
0,1	500	SD 500N100.	1640,-	23
0,2	30	FA 30.	210,-	7
0,2	500	FK 500.	250,-	8
0,2	500	FL 500	500,-	12
0,25	50	FA 50.	210,-	7
0,5	100	FA 100.	210,-	7
0,5	1000	FH 1K.	730,-	11
0,5	1000	FK 1K.	250,-	8
0,5	1000	FL 1K	570,-	12
0,5	1000	FP 1K	1390,-	14
1	200	FA 200.	210,-	7
1	1000	FC 1K	370,-	9
1	2000	FH 2K.	730,-	11
1	2000	FP 2K	1490,-	14
1	2500	FL 2K	600,-	12
1	5000	FH 5K.	940,-	11
1	5000	FP 5K	1690,-	14
2	300	FA 300.	210,-	7
2,5	500	FA 500.	210,-	7
5	10.000	FH 10K.	1100,-	11
5	10.000	FP 10K	2090,-	14
10	20.000	FH 20K.	1110,-	11
10	20.000	FP 20K	2190,-	14
10	50.000	FH 50K.	1290,-	11
10	50.000	FP 50K	2390,-	14
50	100.000	FH 100K.	1450,-	11

# Spring balances SAUTER 287/289

01



KERN 289



KERN 287

NEW



1



2



3

## Mechanical weight and force measurement with quality spring for long service life

### Features

- **The very best price/performance ratio thanks to the transparent plastic housing,** ideal for schools and educational institutions
- **Newton scale:** The KERN 289 range can display the results in Newtons instead of in grammes, specifically for measuring tensile forces
- **High quality:**
  - zero-play spring bearing with highly-precise adjustment
  - fatigue-proof stainless steel spring

- Abrasion-resistant, colour precision scale with high resolution
- Thanks to the rotating inner tube, the scale is always easy to read
- The bracket which is delivered as standard can easily be swapped for another suspension device, so that the system can be individually adapted to the items being weighed
- You will find a wide range of further spring balances with gramme division or Newton division for tension and pressure measurements and specific accessories at [www.sauter.eu](http://www.sauter.eu) and page 26 onwards

### Technical data

- Accuracy of:  $\pm 0,3\%$  of the load
- Tare range: 20 % of [Max]

### Accessories

- **1** Bracket for spring balances of 10-1000 g/ 0,1-10 N, KERN 287-A01, € 25,-
- **2** Hook for spring balances 10-1000 g/ 0,1-10 N, KERN 287-A02, € 25,-
- **3** Bird weighing cone for spring balances (50 – 500 g) KERN 281-891, € 15,-

STANDARD	OPTION
 1 DAY	 2 YEARS WARRANTY
	 ISO +4 DAYS

Model	Division	Measuring range	Load support	Price excl. of VAT ex works €	Option ISO Calibration Certificate	
					ISO KERN	€
SAUTER	N	N				
289-100	0,01	1	hook	75,-	961-161	135,-
289-102	0,05	5	hook	75,-	961-161	135,-
289-104	0,1	10	hook	85,-	961-161	135,-

Model	Division	Weighing range	Load support	Price excl. of VAT ex works €	Option ISO Calibration Certificate	
					ISO KERN	€
SAUTER	g	g				
287-100	0,1	10	clip	75,-	961-100	72,-
287-102	0,2	20	clip	75,-	961-100	72,-
287-104	0,5	50	clip	75,-	961-100	72,-
287-106	1	100	clip	75,-	961-100	72,-
287-108	5	500	clip	75,-	961-100	72,-
287-110	10	1000	clip	85,-	961-100	72,-



# Mechanical force gauge SAUTER FA



## Mechanical force gauge for measuring push and pull forces with peak hold function

### Features

- **Dual scale:** shows Newton and kg
- **Turnable display** unit for an easy adjustment of the instrument
- **Peak hold function** by drag pointer
- Can be mounted on all manual test stands
- Zeroing by a short push of the switch
- **1** Delivered in a hard carrying case
- **2** Standard attachments: as shown below, extension rod: 90 mm

### Technical data

- Precision: 1 % of [Max]
- Dimensions WxDxH 355x58x59 mm
- Thread: M6
- Net weight approx. 0,617 kg

### Accessories

- **2** Standard attachments, SAUTER AC 43, € 45,-
- Further accessory see [www.sauter.eu](http://www.sauter.eu) and page 26 et seqq.

STANDARD



OPTION



Model	Measuring range [Max] N	Readout [d] N	Price excl. of VAT ex works €	Option ISO Calibration Certificate					
				Tension		Compression		Tension/Compression	
				ISO KERN	€	ISO KERN	€	ISO KERN	€
SAUTER FA 10.	10	0,05	210,-	961-161	135,-	961-261	135,-	961-361	245,-
FA 20.	20	0,1	210,-	961-161	135,-	961-261	135,-	961-361	245,-
FA 30.	30	0,2	210,-	961-161	135,-	961-261	135,-	961-361	245,-
FA 50.	50	0,25	210,-	961-161	135,-	961-261	135,-	961-361	245,-
FA 100.	100	0,5	210,-	961-161	135,-	961-261	135,-	961-361	245,-
FA 200.	200	1	210,-	961-161	135,-	961-261	135,-	961-361	245,-
FA 300.	300	2	210,-	961-161	135,-	961-261	135,-	961-361	245,-
FA 500.	500	2,5	210,-	961-161	135,-	961-261	135,-	961-361	245,-



## Robust Push/Pull force gauge for simple measurement

### Features

- **Turnable display:** automatic direction identification
- **Secure operability** due to ergonomic design
- **Peak-Hold function** to capture peaks (measurement result will be “frozen” for a short time) or **Track function** mode for a continuous measurement indication (period of time approx. 10 s)
- Selectable measuring units: N, lb, kg, oz
- **Auto-Power-Off**
- **Standard attachments:** as shown below, extension rod: 90 mm
- Can be mounted on all SAUTER test stands

### Technical data

- Precision: 0,5 % of [Max]
- Internal measuring frequency: 1000 Hz
- Overload protection: 200 % of [Max]
- Dimensions WxDxH 195x82x35 mm
- Thread: M8
- Net weight approx. 0,72 kg

### Accessories

- **2** With one of the two optional attachments for tensile strength testing, the SAUTER FK can become a tensiometer for testing the material tension characteristics of cables, threads, wires, twine etc. (up to Ø 5 mm):
  - **Tensiometer attachment with Safe-insert function:** Pull and release to insert the running cable in between the rolls, for tensile strength testing up to 250 N, aluminium attachment, rollers can be adjusted towards the inside, SAUTER FK-A01, € 210,-
  - **Tensiometer kit for high-capacity tensile strength testing** up to 1000 N, steel attachment and steel rollers, rollers cannot be adjusted, SAUTER FK-A02, € 290,-
- Further accessory see [www.sauter.eu](http://www.sauter.eu) and page 26 et seqq.
- **Standard attachments,** SAUTER AC 430, € 45,-

#### STANDARD



#### OPTION



Model	Measuring range [Max] N	Readout [d] N	Price excl. of VAT ex works €	Option ISO Calibration Certificate					
				Tension		Compression		Tension/Compression	
				ISO KERN	€	ISO KERN	€	ISO KERN	€
SAUTER FK 10.	10	0,005	250,-	961-161	135,-	961-261	135,-	961-361	245,-
FK 25.	25	0,01	250,-	961-161	135,-	961-261	135,-	961-361	245,-
FK 50.	50	0,02	250,-	961-161	135,-	961-261	135,-	961-361	245,-
FK 100.	100	0,05	250,-	961-161	135,-	961-261	135,-	961-361	245,-
FK 250.	250	0,1	250,-	961-161	135,-	961-261	135,-	961-361	245,-
FK 500.	500	0,2	250,-	961-161	135,-	961-261	135,-	961-361	245,-
FK 1K.	1000	0,5	250,-	961-162	165,-	-	-	-	-



# Digital force gauge SAUTER FC

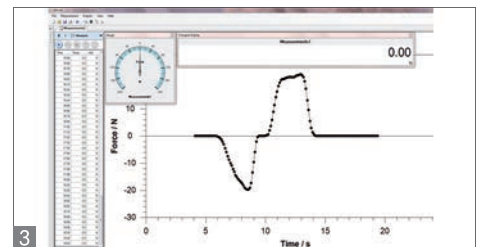

01

## Compact force measuring device

### Features

- **Turnable display** with backlight
- **Peak-Hold function** to capture peaks (measurement result will be “frozen” for a short time) or **Track function** mode for a continuous measurement indication (period of time approx. 10 s)
- **Metal housing** for durable usage in harsh environmental conditions
- **Capacity display:** A bar lights up to show how much of the measuring range is still available
- **Function to set limits**, programming of Max./Min., in pull and push direction, with output of acoustic and optical signal. Ideal mode for efficient and accurate testing of standard parts
- **Safety:** If loads exceed 110 % of the measuring range, the device will give clear acoustic and visual signals
- **Internal memory** for up to 1000 measurements

### Data interface RS-232

- (only for connection to the printer)
- Selectable: AUTO-OFF function or permanent operation
- **1** Delivered in a hard carrying case
- Selectable measuring units: N, kg, oz, lb
- **2** Standard attachments: as shown below
- Can be mounted on all SAUTER test stands (with adapter plate)

### Technical data

- Precision: 0,2 % of [Max]
- Internal measuring frequency: 1000 Hz
- Overload protection: 150 % of [Max]
- Overall dimensions WxDxH 145x73x34 mm
- Thread: M6
- Net weight approx. 940 g
- Permissible ambient temperature -10 °C/40 °C

### Accessories

- **3 Force-time data transfer software** for graphical representation on the PC and data transfer to Microsoft Excel, SAUTER AFH FAST, € 115,-
- **Force-displacement data transfer software** with graphic display of the measurement process, SAUTER AFH FD, € 650,-
- **2 Standard attachments**, SAUTER AC 43, € 45,-
- Further accessory see [www.sauter.eu](http://www.sauter.eu) and page 26 et seqq.

STANDARD



OPTION



Model	Measuring range [Max] N	Readout [d] N	Price excl. of VAT ex works €	Option ISO Calibration Certificate					
				Tension		Compression		Tension/Compression	
				ISO KERN	€	ISO KERN	€	ISO KERN	€
SAUTER FC 10	10	0,01	370,-	961-161	135,-	961-261	135,-	961-361	245,-
FC 50	50	0,01	370,-	961-161	135,-	961-261	135,-	961-361	245,-
FC 100	100	0,1	370,-	961-161	135,-	961-261	135,-	961-361	245,-
FC 500	500	0,1	370,-	961-161	135,-	961-261	135,-	961-361	245,-
FC 1K	1000	1	370,-	961-162	165,-	-	-	-	-



## Universal digital force gauges for tension and compression tests with integrated measuring cell and RS-232 data interface

### Features

- **Turnable display** with backlight
- **1** Can be mounted on all SAUTER test stands
- Digital force gauge with internal sensor
- **Data interface RS-232**, included
- **2** Standard attachments: as shown below, extension rod: 90 mm
- **3** Delivered in a hard carrying case
- Selectable measuring units: N, lb, kg
- **Peak-Hold function** to capture peaks (measurement result will be "frozen" for a short time) or **Track function** mode for a continuous measurement indication (period of time approx. 10 s)
- **Function to set limits**, programming of Max./Min., in pull and push direction, with output of acoustic and optical signal. Ideal mode for efficient and accurate testing of standard parts
- **Auto-Power-Off**

- **Internal memory** for up to 10 measurements
- **Mini Statistics Kit:** calculates the average result from up to ten stored single results, min., max., n

### Technical data

- High resolution: up to 10,000 points (total measuring range)
- Internal measuring frequency: 2000 Hz
- Precision: 0,5 % of [Max]
- Overload protection: 150 % of [Max]
- Dimensions WxDxH 66x36x230 mm
- Thread: M6
- Rechargeable battery pack integrated, standard, operating time up to 12 h without backlight, charging time approx. 4 h
- Net weight approx. 0,64 kg

### Accessories

- **Relais module**, serves to amplify the output signal of the dynamometer to control direct actions, SAUTER AFH-02, **€ 340,-**
- **Force-time data transfer software** for graphical representation on the PC and data transfer to Microsoft Excel, SAUTER AFH FAST, **€ 115,-**
- **Force-displacement data transfer software** with graphic display of the measurement process, SAUTER AFH FD, **€ 650,-**
- **Thermal printer**, SAUTER YKB-01N, **€ 325,-**
- **2 Standard attachments**, SAUTER AC 43, **€ 45,-**
- Further accessory see [www.sauter.eu](http://www.sauter.eu) and page 26 et seqq.

STANDARD



OPTION



Model	Measuring range [Max]	Readout [d]	Price excl. of VAT ex works €	Option ISO Calibration Certificate					
				Tension		Compression		Tension/Compression	
				ISO KERN	€	ISO KERN	€	ISO KERN	€
SAUTER FH 2.	2	0,001	460,-	961-161	135,-	961-261	135,-	961-361	245,-
FH 5.	5	0,001	460,-	961-161	135,-	961-261	135,-	961-361	245,-
FH 10.	10	0,005	460,-	961-161	135,-	961-261	135,-	961-361	245,-
FH 20.	20	0,01	460,-	961-161	135,-	961-261	135,-	961-361	245,-
FH 50.	50	0,01	460,-	961-161	135,-	961-261	135,-	961-361	245,-
FH 100.	100	0,05	460,-	961-161	135,-	961-261	135,-	961-361	245,-
FH 200.	200	0,1	460,-	961-161	135,-	961-261	135,-	961-361	245,-
FH 500.	500	0,1	460,-	961-161	135,-	961-261	135,-	961-361	245,-



# Digital force gauge SAUTER FH-M



01

## Force measuring devices with RS-232 data interface and with external measuring cells

### Features

- **Turnable display** with backlight
- Digital force gauge with remote sensor
- Cable length: approx. 3 m
- **Data interface RS-232**, included
- Delivered in a hard carrying case
- Selectable measuring units: N, lb, kg, KN, t
- **Peak-Hold function** to capture peaks (measurement result will be "frozen" for a short time) or **Track function** mode for a continuous measurement indication (period of time approx. 10 s)
- **Function to set limits**, programming of Max./Min., in pull and push direction, with output of acoustic and optical signal. Ideal mode for efficient and accurate testing of standard parts
- **Auto-Power-Off**
- **Internal memory** for up to 10 measurements

- **Mini Statistics Kit:** calculates the average result from up to ten stored single results, min., max., n

### Technical data

- High resolution: up to 10,000 points (total measuring range)
- Measuring frequency: 2000 Hz
- Precision: 0,5 % of [Max]
- Overload protection: 150 % of [Max]
- Dimensions housing WxDxH 66x36x230 mm
- Rechargeable battery pack integrated, standard, operating time up to 12 h without backlight, charging time approx. 4 h
- Tension loops and compression plates are included in delivery

### FH 1K. – FH 20K.:

- Dimensions sensor WxDxH 51x76,2x19 mm
- Thread: M12

### FH 5K. – FH 20K.:

- Dimensions sensor WxDxH 76,2x50,8x28,2 mm
- Thread: M12

### FH 50K.:

- Dimensions sensor WxDxH 76,3x108x25,5 mm
- Thread: M18

### FH 100K.:

- Dimensions sensor WxDxH 125,2x178x51,3 mm
- Thread: M30

### Accessories

- **Relais module**, serves to amplify the output signal of the dynamometer to control direct actions, SAUTER AFH-02, € 340,-
- **Force-time data transfer software** for graphical representation on the PC and data transfer to Microsoft Excel, SAUTER AFH FAST, € 115,-
- **Force-displacement data transfer software** with graphic display of the measurement process, SAUTER AFH FD, € 650,-
- **Thermal printer**, SAUTER YKB-01N, € 325,-
- Further accessory see [www.sauter.eu](http://www.sauter.eu) and page 26 et seqq.

### STANDARD



### OPTION



Model	Measuring range [Max] KN	Readout [d] N	Price excl. of VAT ex works €	Option ISO Calibration Certificate					
				Tension		Compression		Tension/Compression	
				ISO KERN	€	ISO KERN	€	ISO KERN	€
FH 1K.	1	0,5	730,-	961-162	165,-	961-262	165,-	961-362	300,-
FH 2K.	2	1	730,-	961-162	165,-	961-262	165,-	961-362	300,-
FH 5K.	5	1	940,-	961-163	225,-	961-263	225,-	961-363	405,-
FH 10K.	10	5	1100,-	961-163	225,-	-	-	-	-
FH 20K.	20	10	1110,-	961-164	350,-	-	-	-	-
FH 50K.	50	10	1290,-	961-165	520,-	-	-	-	-
FH 100K.	100	50	1450,-	961-166	940,-	-	-	-	-



## Premium force measuring instrument with graphic-assisted display

### Features

- **Turnable display** with backlight
- **Peak-Hold function** to capture peaks (measurement result will be “frozen” for a short time) or **Track function** mode for a continuous measurement indication (period of time approx. 10 s)
- **Metal housing** for durable usage in harsh environmental conditions
- Can be mounted on all SAUTER test stands
- **Capacity display:** A bar lights up to show how much of the measuring range is still available
- **Function to set limits**, programming of Max./Min., in pull and push direction, with output of acoustic and optical signal. Ideal mode for efficient and accurate testing of standard parts
- **Internal memory** for up to 500 measurements

- **Continuous analogue output:** Linear voltage signal in relation to the load (-2 to +2V)
- **1** Delivered in a hard carrying case
- **2** SAUTER FL 2K: with external sensor, Tension loops and pressure plates are included in delivery
- **3** Standard attachments: as shown besides (not for FL 2K)
- Selectable measuring units: N, KN, kg, oz, lbf

### Technical data

- Internal measuring frequency
- Precision: 0,2 % of [Max]
- Overload protection: 120 % of [Max]
- Dimensions WxDxH 175x75x30 mm
- Thread: M6

- Rechargeable battery pack integrated, standard, operating time up to 10 h without backlight, charging time approx. 8 h
- Net weight approx. 0,5 kg

### Accessories

- **Force-time data transfer software** for graphical representation on the PC and data transfer to Microsoft Excel, SAUTER AFH FAST, € 115,-
- **Force-displacement data transfer software** with graphic display of the measurement process, SAUTER AFH FD, € 650,-
- USB cable, SAUTER FL-A01, € 49,-
- **RS-232 adapter cable**, SAUTER FL-A04, € 49,-
- Further accessory see [www.sauter.eu](http://www.sauter.eu) and page 26 et seqq.

### STANDARD



### OPTION



Model	Measuring range [Max] N	Readout [d] N	Price excl. of VAT ex works €	Option ISO Calibration Certificate					
				Tension		Compression		Tension/Compression	
				ISO KERN	€	ISO KERN	€	ISO KERN	€
SAUTER FL 5	5	0,002	500,-	961-161	135,-	961-261	135,-	961-361	245,-
FL 10	10	0,005	500,-	961-161	135,-	961-261	135,-	961-361	245,-
FL 20	25	0,01	500,-	961-161	135,-	961-261	135,-	961-361	245,-
FL 50	50	0,02	500,-	961-161	135,-	961-261	135,-	961-361	245,-
FL 100	100	0,05	500,-	961-161	135,-	961-261	135,-	961-361	245,-
FL 200	250	0,1	500,-	961-161	135,-	961-261	135,-	961-361	245,-
FL 500	500	0,2	500,-	961-161	135,-	961-261	135,-	961-361	245,-
FL 1K	1000	0,5	570,-	961-162	165,-	-	-	-	-
FL 2K	2500	1	600,-	961-162	165,-	961-262	165,-	961-362	300,-

# Digital premium force measuring device SAUTER FP-S

**NEW** **PREMIUM** ★★★



## Force measuring device with graphic function and integrated measuring cell

### Features

- **TFT graphic-display** with backlight, 240x320 pixel, turnable display
- **Graphics display** shows the force progression of a measurement as a graphic
- **Internal data memory** saves all measurements from a complete measurement process. The content of the memory can be transferred to the PC using optional software
- **Metal housing** for durable usage in harsh environmental conditions
- Can be mounted on all SAUTER test stands
- **USB data interfaces** to the PC included
- **Peak hold function** to capture the peak value or **Track function** for continuous display of the measurement

- **Function to set limits**, programming of Max./Min., in pull and push direction, with output of acoustic and optical signal. Ideal mode for efficient and accurate testing of standard parts
- **Auto Power-Off**
- **Scope of delivery**: Standard attachments as shown, 90 mm extension rod, sturdy carry case

### Technical data

- Units can be selected: N, lb, kg, oz
- Precision:  $\pm 0,5\%$  of [Max]
- Measuring frequency: 2000 Hz
- High resolution: up to 10,000 points (total measuring range)
- Overload protection: 150 % of [Max]
- Dimensions WxDxH 238x69x36 mm

- Thread: M6
- Rechargeable battery pack integrated, standard, operating time up to 6 h without backlight, charging time approx. 14 h
- Net weight approx. 0,7 kg

### Accessories

- **Force-time data transfer software** for graphical representation on the PC and data transfer to Microsoft Excel, SAUTER AFH FAST, € 115,-
- **Force-displacement data transfer software** with graphic display of the measurement process, SAUTER AFH FD, € 650,-
- **Standard attachments** for all force-measuring devices FA, FH, FL, FC, FP-S, can be reordered at any time, SAUTER AC 43, € 45,-
- Further accessory see [www.sauter.eu](http://www.sauter.eu) and page 26 et seqq.

STANDARD



OPTION



Model	Measuring range [Max] N	Readout [d] N	Price excl. of VAT ex works €	Option ISO Calibration Certificate					
				Tension		Compression		Tension/Compression	
				ISO KERN	€	ISO KERN	€	ISO KERN	€
SAUTER FP 2	2	0,001	990,-	961-161	135,-	961-261	135,-	961-361	245,-
SAUTER FP 5	5	0,001	990,-	961-161	135,-	961-261	135,-	961-361	245,-
SAUTER FP 10	10	0,005	990,-	961-161	135,-	961-261	135,-	961-361	245,-
SAUTER FP 20	20	0,01	990,-	961-161	135,-	961-261	135,-	961-361	245,-
SAUTER FP 50	50	0,01	990,-	961-161	135,-	961-261	135,-	961-361	245,-
SAUTER FP 100	100	0,05	990,-	961-161	135,-	961-261	135,-	961-361	245,-
SAUTER FP 200	200	0,1	990,-	961-161	135,-	961-261	135,-	961-361	245,-
SAUTER FP 500	500	0,1	990,-	961-161	135,-	961-261	135,-	961-361	245,-



# Digital premium force measuring device SAUTER FP-M

01

**NEW** **PREMIUM** ★★★



## Force measuring devices with graphics function and external measuring cell

### Features

- **TFT graphic-display** with backlight, 240x320 pixel, turnable display
- **Graphics display** shows the force progression of a measurement as a graphic
- **Internal data memory** saves all measurements from a complete measurement process. The content of the memory can be transferred to the PC using optional software
- **Metal housing** for durable usage in harsh environmental conditions
- Can be mounted on all SAUTER test stands
- **USB data interfaces** to the PC included
- **Peak hold function** to capture the peak value or **Track function** for continuous display of the measurement
- **Function to set limits**, programming of Max./Min., in pull and push direction, with output of acoustic and optical signal. Ideal

mode for efficient and accurate testing of standard parts

- **Auto Power-Off**
- Scope of delivery: Tension loops, pressure plates, sturdy carry case

### Technical data

- Units can be selected: N, lb, kg, oz
- Precision:  $\pm 0,5\%$  of [Max]
- Measuring frequency: 2000 Hz
- High resolution: up to 10,000 points (total measuring range)
- Overload protection: 150 % of [Max]
- Dimensions display unit WxDxH 238x69x36 mm
- Rechargeable battery pack integrated, standard, operating time up to 6 h without backlight, charging time approx. 14 h
- Net weight approx. 0,7 kg

### Accessories

- **Force-time data transfer software** for graphical representation on the PC and data transfer to Microsoft Excel, SAUTER AFH FAST, € 115,-
- **Force-displacement data transfer software** with graphic display of the measurement process, SAUTER AFH FD, € 650,-
- Further accessory see [www.sauter.eu](http://www.sauter.eu) and page 26 et seqq.

STANDARD



OPTION



Model	Measuring range [Max] KN	Readout [d] N	Dimensions sensor, approx. WxDxH mm	Thread	Price excl. of VAT ex works €	Option ISO Calibration Certificate					
						Tension		Compression		Tension/Compression	
						ISO KERN	€	ISO KERN	€	ISO KERN	€
SAUTER FP 1K	1	0,5	50,8x19x76,2	M12 x 1,75	1390,-	961-162	165,-	961-262	165,-	961-362	300,-
FP 2K	2	1	50,8x19x76,2	M12 x 1,75	1490,-	961-162	165,-	961-262	165,-	961-362	300,-
FP 5K	5	1	50,8x28,2x76,2	M12 x 1,75	1690,-	961-163	225,-	961-263	225,-	961-363	405,-
FP 10K	10	5	50,8x28,2x76,2	M12 x 1,75	2090,-	961-163	225,-	-	-	-	-
FP 20K	20	10	50,8x28,2x76,2	M12 x 1,75	2190,-	961-164	350,-	-	-	-	-
FP 50K	50	10	76,2x25,4x108	M18 x 1,5	2390,-	961-166	520,-	-	-	-	-



## Manual test stand for highly accurate tensile and compressive force measurement, with length measurement

### Features

- For vertical and horizontal use
- Precise measurement results
- **High level of security** with repeated measurements
- **Large base plate** with various holes for fixture mountings
- Can be used for force gauges up to 500 N (not included)

### Digital length meter

- Measuring range: max. 200 mm
- Readout: 0,01 mm
- Zero setting possible
- Pre-length can be set manually

### Technical data

- Max travel from base plate: 297 mm
- Travel distance per knob rotation (one turn): 3,1 mm
- Overall dimensions WxDxH 151x234x465 mm
- Net weight approx. 8,3 kg

STANDARD



Model	Measuring range	Price excl. of VAT ex works €
KERN	[Max] N	
TVL	500	<b>370,-</b>



SAUTER TVP.



SAUTER TVP-L.

Manual test stands for compressive force measurement, also with digital length measurement

**Features**

- Provides quick and consistent testing
- **High level of security** with repeated measurements
- **Provides maximum versatility** and precise measuring results
- **Slide construction** for distance measurement
- **Large base plate** with various holes for fixture mountings
- Can be used for force gauges up to 500 N (not included)

**TVP-L:**

- **Digital length meter**
  - Measuring range: 100 mm
  - Readout: 0,01 mm
  - Zero setting possible
  - Pre-length can be set manually

**Technical data**

- Maximum carriage height above base plate: 318 mm
- Max travel with one stroke: 78 mm
- Overall dimensions WxDxH 150x233x420 mm
- Net weight approx. 10,5 kg

STANDARD

SCALE
 FAST-MOVE
 1 DAY
 2 YEARS WARRANTY

only TVP-L.

Model	Measuring range [Max] N	Price excl. of VAT ex works €
SAUTER TVP.	500	310,-
with digital length meter		
TVP-L.	500	370,-



# Crank test stand SAUTER TPE

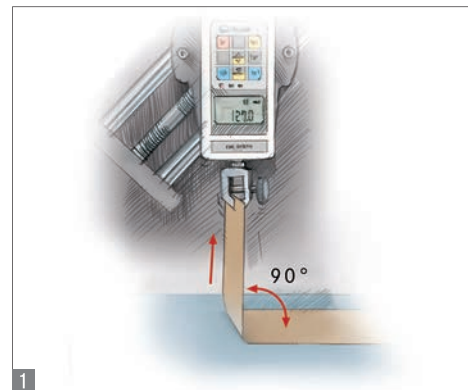

01

## Test stand for 90° peel tests with simple operation

### Features

- **1** The SAUTER test stand TPE has been developed specifically for peel testing. Typically this involves pulling a bonded material layer from a base material (see diagram)
- Safe reliable operation due to the crank
- As a general rule the significant value in this process is the force required to pull away the top layer from bonded material
- The SAUTER TPE has been designed such that the force measuring unit exerting the force simultaneously moves sideways and upwards. This means that a peel-off movement is produced, avoiding shear forces which could distort the result.

- The test unit moves at an angle of 45° to the horizontal. The force-measurement device is fitted in an exact vertical position
- **2** Suitable for all SAUTER force measuring devices up to 500 N (not included)

### Technical data

- Travel distance per knob rotation (one turn): 3,1 mm
- Maximum stripping length: 105 mm
- Overall dimensions WxDxH 420x215x480 mm
- Net weight approx. 22 kg

STANDARD



Model	Price excl. of VAT ex works €
SAUTER TPE.	630,-

**ONLY WHILE STOCKS LAST!**

For more information, please visit [www.sauter.eu/en/TPE](http://www.sauter.eu/en/TPE) · Order hotline +49 [0] 7433 9933-0

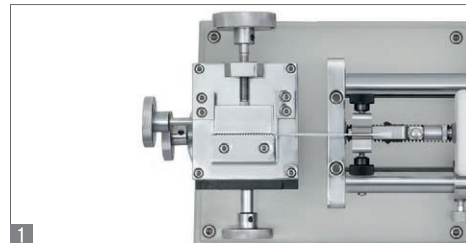
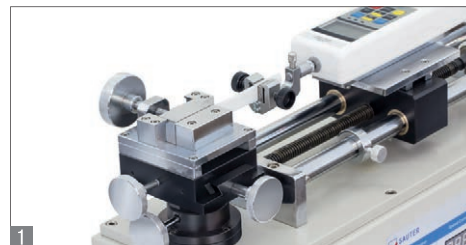

Motorised test stand with digital display for horizontal force measurement where the highest standards are required

### Features

- **Easy to use**
- Efficient working
- Robust design and heavy duty metal construction
- **Height-adjustable angle table.** The clamping vice can be locked and finely adjusted sideways and up/down using the setting wheel.
- **Repeat function** for fatigue tests
- Digital speed display to read the process speed straightaway
- **Premium operating panel:**
  - Digital speed display
  - Digital repeat function
  - Control of the test bench using SAUTER AFH PC software
- **Solid and versatile fixing options** of SAUTER force measuring devices, see accessory page 26 et seqq.
- **A wide range of interfaces** for an easy transfer of the data collected

- Suitable for all SAUTER force measuring devices up to 500 N (not supplied with the product)

### Technical data

- Minimum distance between left and right object fastening: 30 mm
- Maximum travel length: 250 mm (protected by electronic end switches)
- Overall dimensions WxDxH 170x345x550 mm
- Net weight approx. 35 kg

### Accessories

- **Digital length measuring device**, measuring range 200 mm, readout 0,01 mm, details see page 36, SAUTER LB 200-2., **€ 610,-**
- **Mounting the length measuring device** onto a SAUTER test stand at the factory, SAUTER LB-A02, **€ 190,-**

#### STANDARD



#### OPTION



Model	Measuring range	Speed range	Price excl. of VAT ex works €
SAUTER THM 500N500N	[Max] N 500	mm/min 50 - 500	<b>2250,-</b>

# Motorised vertical test stand SAUTER TVO



## Premium test stand for laboratory applications

### Features

- Motorised test stand for tension and compression tests
- **Table-top design** for comfortable operation
- **Robust design** for durable use
- Easy-to-access safety switch-off
- Upper and lower end point, can be set individually
- Automatic or manual operation mode
- Can be used for force gauges up to 500 N (e.g. SAUTER FH, not included, for details see page 10)

### Technical data

- Maximum tensile and compressive force: 500 N
- Maximum travel length: 300 mm
- Speed accuracy: 2 % of [Max]
- Net weight approx. 25 kg

### Accessories

- **Digital length measuring device**, measuring range 300 mm, readout 0,01 mm, details see page 36, SAUTER LB 300-2., € 630,-
- **Mounting the length measuring device** onto a SAUTER test stand at the factory, SAUTER LB-A02, € 190,-

#### STANDARD



#### OPTION



Model	Measuring range [Max] N	Speed range mm/min	Max. travelling distance mm	Motor	Dimensions WxDxH mm	Price excl. of VAT ex works €
<b>SAUTER TVO 500N300.</b>	500	15 - 300	300	Electric driven motor	236x428x570	<b>1650,-</b>

🚨 ONLY WHILE STOCKS LAST!



# Motorised vertical test stand SAUTER TVO-S

01

NEW



SAUTER TVO-S ≤ 1 KN



SAUTER TVO-S ≥ 2 KN

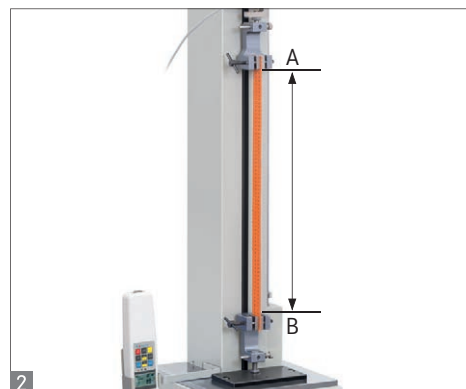

Premium test bench in table-top version – now also with step motor

## Features

- Motorised test stand for tension/compression force testing
- **New: Step motor for greatest ease of use**
  - for constant speed from the smallest to the maximum load
  - allows testing at minimum speed and full load
  - for higher positioning accuracy. Precise starting and stopping, without run-on, even at high speeds
  - precise adjustment of the process speed using the information shown on the display
- **A wide range of application** possibilities because of its large travel path
- Automatic or manual process mode
- **Premium operating panel**
  - Digital speed display
  - Digital repeat function
  - Control of the test stand using SAUTER AFH PC software
- **Table-top version** for easy operation

- **Robust construction;** fixation of SAUTER force measuring devices up to 2 KN possible
- Mounting option of different clamps
- The large diagram shows the TVO-S test stand with SAUTER FH force measuring device as well as mounts for the force measuring device and test objects, not supplied with the product

## Technical data

- Process speed: 1 % tolerance of the display against the actual speed
- Positioning accuracy when shutting down: ± 0,05 mm
- Dimensional drawings on [www.sauter.eu](http://www.sauter.eu)

## Accessories

- **Digital length measuring device** SAUTER LB, only for TVO 500N300S and TVO 500N300, SAUTER LB 300-2., **€ 630,-**
- **Fatigue testing data transfer software,** SAUTER AFH FGT, **€ 850,-**
- **Force-time data transfer software** for graphical representation on the PC and data transfer to Microsoft Excel, SAUTER AFH FAST, **€ 115,-**
- **Force-displacement data transfer software** with graphic display of the measurement process, SAUTER AFH FD, **€ 650,-**
- **Mount for measuring device** SAUTER FH, SAUTER TVO-A01, **€ 70,-**

STANDARD



OPTION



Model	Measuring range [Max] N	Speed range mm/min	Max. travelling distance mm	Motor	Dimensions WxDxH mm	Price excl. of VAT ex works €
SAUTER TVO 500N500S	500	1 - 500	300	Syncronal stepper motor	286x380x680	3090,-
SAUTER TVO 1000N500S	1000	1 - 500	500	Syncronal stepper motor	270x410x970	3250,-
SAUTER TVO 2000N500S	2000	1 - 500	700	Syncronal stepper motor	310x465x1180	4450,-

# Motorised vertical test stand SAUTER TVM-N · TVM-NL



NEW

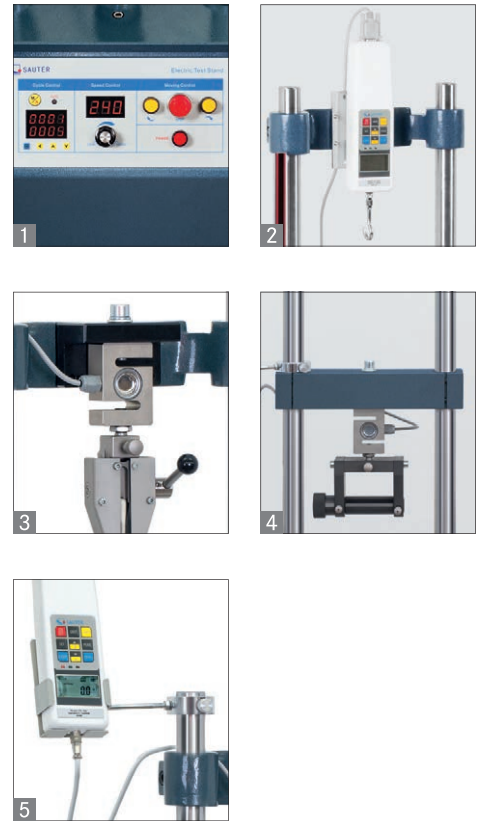

01

## Test stand with electric motor for standard measurements – now with longer guide columns

### Features

- **New:** Longer guide columns as standard, for greater range of movement or longer test objects, and as a result, it is optimised for new fixing options
- **Premium operating panel**
  - Digital speed display
  - Digital repeat function
  - Control of the test stand using SAUTER AFH PC software
- **Force controlled automatic switchoff,** Teststop after achieving an adjusted limit load, only in connection with a SAUTER FH force gauge
- **Repeat function** for fatigue tests (multiple up and down), adjustable
- **Digital speed display** so that you read the process speed straightaway
- Maximum travel ensured by electronic end switch

- SAUTER LA length measuring device as standard, to read the measurement range with a readout of 0.01 mm
- **Solid and versatile fixing options** of SAUTER force measuring devices, see accessory page 26 et seqq.
- Many fixation options of force measuring devices, such as SAUTER FH, FA, FK, FL:
  - **2** Force gauges with internal sensor up to 500 N capacity (only TVM 5000N230N and TVM 10KN120N)
  - **3** Force gauges with external sensor starting from 1.000 N capacity
  - **4** cross beam for TVM-N. ≥ 20 KN
  - **5** side mount for the force measuring device for devices with external measuring cell, SAUTER TVM-A01, € 70,-
- The big illustration shows the test stand TVM-N with length measuring device SAUTER LB, readout 0.01mm. Force gauge and mount for force gauge and test objects are not included in delivery

### Technical data

- Process speed: 3 % tolerance
- Speed accuracy: 3 % of [Max]
- Initial height of the mounting plate from the upper edge of the motor housing: 171 mm
- Maximum lift of the mounting plate: 385 mm
- Minimal distance between the mounting plate and the underside of the upper device mounting: 85 mm
- Overall dimensions WxDxH 410x255x1550 mm
- Net weight on request

### Accessories

- **Digital length measuring device,** measuring range 300 mm, readout 0,01 mm, details see page 36, SAUTER LB 300-2, € 630,-
- **Mounting the length measuring device** onto a SAUTER test stand at the factory, SAUTER LB-A02, € 190,-
- Mount for measuring device, e.g. SAUTER FH, FA, FK, FL, SAUTER TVM-A01, € 70,-
- **Longer columns** with the same travel distance, up to 500 mm, SAUTER AFH 18, € 560,-

STANDARD



OPTION



Model	Measuring range [Max] N	Speed range mm/min	Length of columns mm	Max. travelling distance mm	Price excl. of VAT ex works €
SAUTER TVM 5000N230N.	5000	10 - 230	635	214	1910,-
SAUTER TVM 5000N230NL	5000	10 - 230	1135	214	2050,-
SAUTER TVM 10KN120N.	10000	30 - 120	1135	214	2600,-
SAUTER TVM 20KN120N.	20000	30 - 120	1135	214	3390,-
SAUTER TVM 30KN70N.	30000	5 - 70	1135	214	4000,-

# Motorised vertical test stand SAUTER TVS

01



**NEW** **PREMIUM** ★★★



## Premium test stand with step motor for precise testing up to 50 KN

### Features

- Motorised test stand for tension/compression force testing
- **Premium operating panel**
  - Digital speed display
  - Digital repeat function
  - Control of the test stand using SAUTER AFH PC software
- **New: Step motor for greatest ease of use**
  - for constant speed from the smallest to the maximum load
  - allows testing at minimum speed and full load
  - for higher positioning accuracy. Precise starting and stopping, without overrun, even at high speeds
  - precise adjustment of the process speed using the information shown on the display
- Maximum travel ensured by electronic end switch
- **Large working area** by means of long guide columns as standard, which allows a wide range of fixing options

- SAUTER LA length measuring device as standard, to read the measurement range with a readout of 0.01 mm
- TVS test stand (large diagram) with SAUTER LA length measuring device, readout 0.01 mm. Force measuring device and mount for force measuring device and test object not supplied with the product
- For force-displacement testing: Please order the optional SAUTER LB length measuring device as well as the AFH FD software with the product

### Technical data

- Process speed: 1 % of [Max]
- Positioning accuracy when shutting down: ± 0,05 mm
- Initial height of the mounting plate from the upper edge of the motor housing: 171 mm
- Maximum lift of the mounting plate: 385 mm

- Minimal distance between the mounting plate and the underside of the upper device mounting: 85 mm
- Overall dimensions WxDxH 410x255x1550 mm
- Net weight on request
- For dimensional drawing see [www.sauter.eu](http://www.sauter.eu)

### Accessories

- **Digital length measuring device**, measuring range 300 mm, readout 0,01 mm, details see page 36, SAUTER LB 300-2., **€ 630,-**
- **Mounting the length measuring device** onto a SAUTER test stand at the factory, SAUTER LB-A02, **€ 190,-**
- Mount for measuring device, e.g. SAUTER FH, FA, FK, FL, SAUTER TVM-A01, **€ 70,-**
- **Longer columns** with the same travel distance, up to 500 mm, SAUTER AFH 18, **€ 560,-**
- **Fatigue testing data transfer software**, SAUTER AFH FGT, **€ 850,-**
- **Force-time data transfer software** for graphical representation on the PC and data transfer to Microsoft Excel, SAUTER AFH FAST, **€ 115,-**
- **Force-displacement data transfer software** with graphic display of the measurement process, SAUTER AFH FD, **€ 650,-**

STANDARD		OPTION	
 MOTOR	 2 DAYS	 2 YEARS WARRANTY	 SCALE
			 SOFTWARE

Model	Measuring range [Max] N	Speed range mm/min	Max. travelling distance mm	Length of columns mm	Motor	Price excl. of VAT ex works €
<b>SAUTER</b>						
<b>TVS 5000N240</b>	5000	1 - 240	215	1135	Stepper motor	<b>3550,-</b>
<b>TVS 10KN100</b>	10000	1 - 100	215	1135	Stepper motor	<b>4450,-</b>
<b>TVS 20KN100</b>	20000	1 - 100	215	1135	Stepper motor	<b>4650,-</b>
<b>TVS 30KN80</b>	30000	1 - 80	215	1135	Stepper motor	<b>4950,-</b>
<b>TVS 50KN80</b>	50000	1 - 80	215	1135	Stepper motor	<b>6550,-</b>



# Spring tester SAUTER SD-M



01

Manual test stand for tensile and compressive testing of springs, medium version from 50 N up to 500 N

## Features

- Spring tester for tension and compression tests
- **Integrated thermal printer**
- **Digital length measuring unit:**
  - Manual zero adjustment possible
  - Pre-length can be set manually
  - Readout: 0,01 mm
- **10 memories** to print out the results or to calculate average values
- **Function to set limits:** Input of an upper/lower limit value.  
A visual and acoustic signal supports the measuring operation
- **Peak load display** (peak hold)
- Selectable measuring units: kg, lbf, N

## Technical data

- Precision: 0,5 % of [Max]
- Stroke length: 100 mm
- Maximum test object length: 100 mm
- Overall dimensions WxDxH 300x235x620 mm

### STANDARD



### OPTION



Model	Measuring range [Max] N	Readout [d] N	Net weight approx. kg	Price excl. of VAT ex works €	Option	
					ISO KERN	Certificate Compression €
SAUTER						
SD 50N100.	50	0,01	20	1640,-	961-261	135,-
SD 100N100.	100	0,02	17,5	1640,-	961-261	135,-
SD 200N100.	200	0,05	19,1	1640,-	961-261	135,-
SD 300N100.	300	0,1	20,1	1640,-	961-261	135,-
SD 500N100.	500	0,1	20,8	1640,-	961-261	135,-

# Data transfer software SAUTER AFH FAST

01

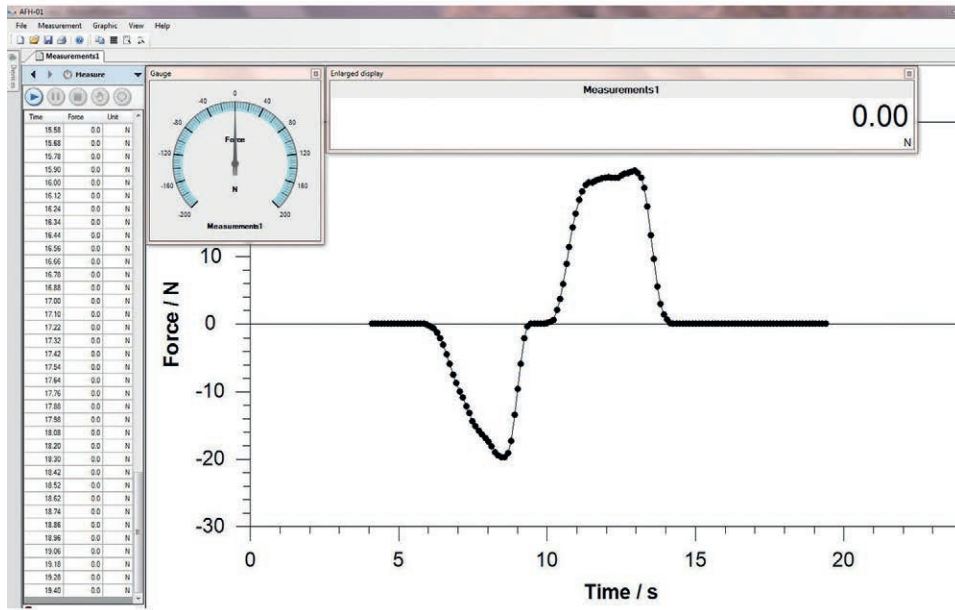

	A	B	C	D	E	G	H	J
1	4.13988093	0 s	N	FH 200	NaN	NaN	NaN	2011-11-09T11:51:26.0937552+01:00
2	4.218979506	0 s	N	FH 200	NaN	NaN	NaN	2011-11-09T11:51:26.0937552+01:00
3	4.318952934	0 s	N	FH 200	NaN	NaN	NaN	2011-11-09T11:51:26.0937552+01:00
4	4.408976966	0 s	N	FH 200	NaN	NaN	NaN	2011-11-09T11:51:26.0937552+01:00
5	4.508946933	0 s	N	FH 200	NaN	NaN	NaN	2011-11-09T11:51:26.0937552+01:00
6	4.608932	0 s	N	FH 200	NaN	NaN	NaN	2011-11-09T11:51:26.0937552+01:00
7	4.70898559	0 s	N	FH 200	NaN	NaN	NaN	2011-11-09T11:51:26.0937552+01:00
8	4.809055448	0 s	N	FH 200	NaN	NaN	NaN	2011-11-09T11:51:26.0937552+01:00
9	4.908950668	0 s	N	FH 200	NaN	NaN	NaN	2011-11-09T11:51:26.0937552+01:00
10	5.008949641	0 s	N	FH 200	NaN	NaN	NaN	2011-11-09T11:51:26.0937552+01:00
11	5.108918311	0 s	N	FH 200	NaN	NaN	NaN	2011-11-09T11:51:26.0937552+01:00
12	5.218946513	0 s	N	FH 200	NaN	NaN	NaN	2011-11-09T11:51:26.0937552+01:00
13	5.318918742	0 s	N	FH 200	NaN	NaN	NaN	2011-11-09T11:51:26.0937552+01:00
14	5.418946693	0 s	N	FH 200	NaN	NaN	NaN	2011-11-09T11:51:26.0937552+01:00
15	5.518918742	0 s	N	FH 200	NaN	NaN	NaN	2011-11-09T11:51:26.0937552+01:00
16	5.618950577	0 s	N	FH 200	NaN	NaN	NaN	2011-11-09T11:51:26.0937552+01:00
17	5.718950523	0 s	N	FH 200	NaN	NaN	NaN	2011-11-09T11:51:26.0937552+01:00
18	5.818979932	0 s	N	FH 200	NaN	NaN	NaN	2011-11-09T11:51:26.0937552+01:00
19	5.918929722	-0.1 s	N	FH 200	NaN	NaN	NaN	2011-11-09T11:51:26.0937552+01:00
20	6.018979994	-0.4 s	N	FH 200	NaN	NaN	NaN	2011-11-09T11:51:26.0937552+01:00
21	6.119279899	-0.7 s	N	FH 200	NaN	NaN	NaN	2011-11-09T11:51:26.0937552+01:00
22	6.218984061	-1 s	N	FH 300	NaN	NaN	NaN	2011-11-09T11:51:26.0937552+01:00
23	6.318998253	-1.3 s	N	FH 200	NaN	NaN	NaN	2011-11-09T11:51:26.0937552+01:00
24	6.418995627	-1.6 s	N	FH 200	NaN	NaN	NaN	2011-11-09T11:51:26.0937552+01:00
25	6.519030754	-1.9 s	N	FH 200	NaN	NaN	NaN	2011-11-09T11:51:26.0937552+01:00
26	6.619079277	-2.2 s	N	FH 200	NaN	NaN	NaN	2011-11-09T11:51:26.0937552+01:00
27	6.719050932	-2.5 s	N	FH 200	NaN	NaN	NaN	2011-11-09T11:51:26.0937552+01:00
28	6.819021903	-2.8 s	N	FH 200	NaN	NaN	NaN	2011-11-09T11:51:26.0937552+01:00
29	6.918993475	-3.1 s	N	FH 200	NaN	NaN	NaN	2011-11-09T11:51:26.0937552+01:00
30	7.018964928	-3.4 s	N	FH 200	NaN	NaN	NaN	2011-11-09T11:51:26.0937552+01:00
31	7.119013711	-3.7 s	N	FH 200	NaN	NaN	NaN	2011-11-09T11:51:26.0937552+01:00
32	7.219018029	-4 s	N	FH 200	NaN	NaN	NaN	2011-11-09T11:51:26.0937552+01:00



## High speed data transfer software for force-time-measurements

### Features

- Force measurements can be conducted over a very short period, i.e. seconds
- A high speed data transfer to a PC is possible (with a transfer of up to 20 data sets per second) when combining the AFH FAST with SAUTER FH, FC or SAUTER FL (only 3 data sets per sec.)
- AFH FAST shows the results in a Force-Time-Graph and can export the data to MS Excel.
- Compatible with the following operating systems: Microsoft Windows 7/8.1

### Technical data

- Data recording rate max.: 20 Hz (with FH, FC), 3 Hz (with FL)
- The following interface cables are supplied with the product
  - RS-232 for FH (FH-A01)
  - RS-232 for FL (FL-A01)
  - USB for FL (FL-A04)

### Accessories

- **RS-232/USB adapter**, to connect peripheral devices with USB connection, SAUTER AFH 12, € 85,-
- **RS-232/Ethernet adapter**, for connection to an IP-based Ethernet network, SAUTER YKI-01, € 390,-

STANDARD



Model	Price excl. of VAT ex works €
SAUTER AFH FAST	115,-

# Data transfer software SAUTER AFH FD

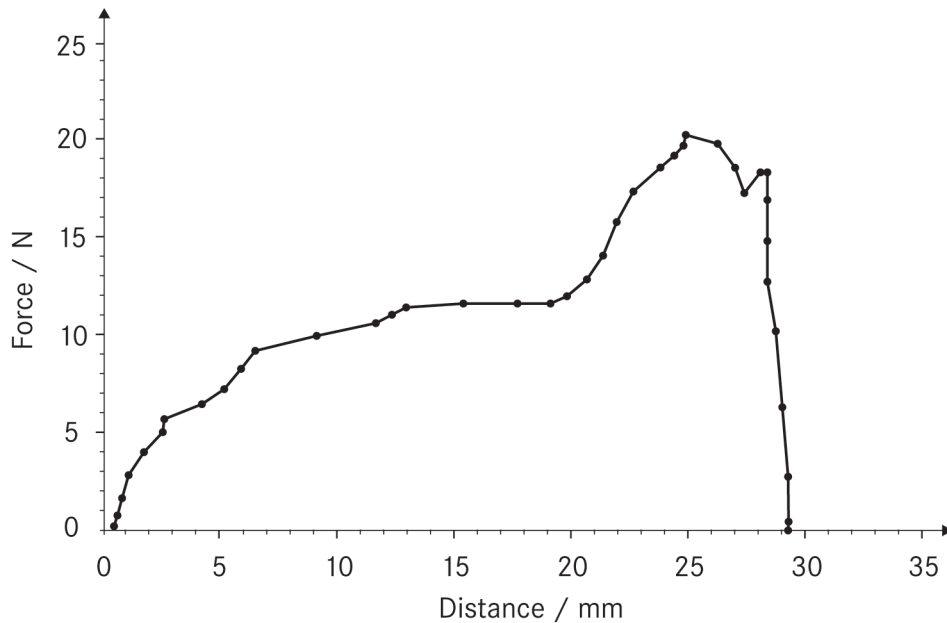

01

## Force-displacement analysis software for testing materials

### Features

- AFH FD software is designed for all applications that require the measurement of forces, depending on the displacement. Typically these are force progression graphs in penetration tests or pullout tests
- The program simultaneously requests the measurements from a force measuring device, e.g. SAUTER FH, as well as a length-measuring device, e.g. SAUTER LB
- The measurements from both instruments are transferred continuously to the PC, synchronised by the AFH FD software and exported in the form of a graphic, as well as free data format for simple processing in Microsoft Excel
- The software AFH FD is compatible with all devices in the SAUTER FH, SAUTER FL and SAUTER LB ranges
- These measuring instruments are usually used with SAUTER test stands, in particular those from the SAUTER TVM-N range. However, it is also possible to use them with other mechanical testing machines

- Further analysis functions:
    - Dimensions of the test object
    - Tensile and compressive force
    - Load test
    - Archiving the recorded data
  - **2** Scope of supply SAUTER AFH FD:
    - AFH FD software on DVD
    - User manual
    - Interface cable RS-232 for FH (FH-A01)
    - Interface cable RS-232 for FL (FL-A01)
    - Interface cable USB for FL (FL-A04)
    - Interface cable RS-232 for LB (LB-A01)
  - Compatible with the following operating systems: Microsoft Windows 7/8.1
  - **3** Order example for a complete test system:
    - FH 5K. (Digital force gauge)
    - LB 300-2. (Digital length measuring device)
    - AFH FD (Force-distance evaluation software)
    - TVM 5000N230N.\* (Test stand)
    - LB-A02\* (Mounting LB on test stands)
    - 2x AFH 12 (RS-232/USB adapter)
    - AC 04\* (Test object holder)
    - 961-163\* (Force calibration)
    - 961-150\* (Length calibration)
- \* not necessarily required for operating the AFH FD software

### Technical data

- Data recording rate max. 3 Hz (specially in combination with SAUTER FH and SAUTER LB)
- Cable length of PC connection cable (RS-232) approx. 1,5 m

### Accessories

- **PC connection cable (RS-232)** as standard, can be retrofitted, for SAUTER FH: SAUTER FH-A01, € 46,- for SAUTER LB: SAUTER LB-A01, € 360,-
- **RS-232/USB adapter**, to connect peripheral devices with USB connection, SAUTER AFH 12, € 85,-

STANDARD







Model	Price excl. of VAT ex works €
SAUTER AFH FD	650,-

## For tension tests ≤ 500 N

	<b>Long clamp</b> for tension and rupture tests up to 50 N, Thread: M6	<b>AC 17</b> € 120,- 2 pieces
	<b>Angle bracket</b> for tension and rupture tests up to 500 N (e.g. for cable tests), Thread: M6	<b>AC 01</b> € 90,- 2 pieces
	<b>Cable fixture</b> for tension and rupture tests up to 500 N (like SAUTER AC 10, small version)	<b>AC 10S*</b> € 65,-
	<b>Fine point clamp</b> for tension and rupture tests up to 500 N, width 15 mm, Thread: M6	<b>AC 14</b> € 55,- 2 pieces
	<b>Fine point clamp</b> for tension and rupture tests up to 500 N, width 22 mm, Thread: M6	<b>AC 22</b> € 85,-
	<b>Ring fixture</b> for tension and rupture tests up to 500 N, Thread: M6	<b>AC 15*</b> € 65,-
	<b>Screw tension clamp</b> for 100 N for laboratory tensile force measurements, incl. Jaws with pyramid grip, Thread: M6	<b>AD 9001</b> € 997,- 2 pieces
	<b>Screw tension clamp</b> for 100 N for laboratory tensile force measurements, incl. Jaws with pyramid grip <b>1</b> with adapter structure for AD-system, <b>2</b> with M6 thread	<b>AD 9005</b> € 576,- 2 pieces
	<b>Screw tension clamp</b> for 100 N for laboratory tensile force measurements with collar joint and Jaws with pyramid grip	<b>AD 9016</b> € 1008,- 2 pieces

## For tension tests 500 N – 5000 N

	<b>Thin film grip</b> for tension tests up to 5 KN (e.g. textile, paper etc.), Thread: M6	<b>AC 03</b> € 105,- 2 pieces
	<b>Grip clamp</b> for insertion and pull tests up to 5 KN, Thread: M6	<b>AC 09</b> € 85,- 2 pieces
	<b>Parallel jaw grip</b> for tension and rupture tests up to 5 KN, Thread: M10	<b>AC 12</b> € 75,- 2 pieces
	<b>High capacity small clamp</b> for tension and rupture tests up to 5 KN, Thread: M10	<b>AC 16</b> € 125,- 2 pieces
	<b>2 wide jaw grip</b> for tension and extraction tests up to 5 KN, Thread: M10	<b>AC 18</b> € 125,- 2 pieces

	<b>Cable fixture</b> for tension and rupture tests up to 5 KN	<b>AC 10*</b> € 105,- 2 pieces
	<b>Rolling-clamp</b> for tension and rupture tests up to 5 KN, Thread: M10	<b>AC 11</b> € 105,- 2 pieces
	<b>1-jaw-clamp</b> for tension and rupture tests up to 5 KN, Thread: M6	<b>AC 13</b> € 75,- 2 pieces
	<b>Eccentric roll clamps</b> in particular for cable tests up to 5 KN, max. opening: 9 mm	<b>AC 41</b> € 175,-
	<b>Drum clamps</b> typically for cable connector extraction tests up to 5 KN, for test objects with Ø from 1,5 mm up to 8 mm, Thread: M10	<b>AC 42</b> € 175,-
	<b>Flat clamp with ripple jaws</b> Thread: M10 up to 10 KN: AC 31	<b>AC 31</b> € 410,-
	<b>Wide jaw clamp with fixed jaws</b> with high-performance inner jaws out of steel, jaws with pyramid grip Thread: M10 up to 5 KN: AC 04 up to 10 KN: AC 37	<b>AC 04</b> € 330,- <b>AC 37*</b> € 1250,-
	<b>Screw-in tension clamp</b> for 1 KN, for tensile force tests, Jaws with pyramid grip	<b>AD 9021</b> € 828,- 2 pieces
	<b>Screw-in tension clamp</b> up to 1 KN, for tensile force tests, clamping width 50 mm, Jaws with pyramid grip	<b>AD 9033</b> € 1188,- 2 pieces
	<b>Screw-in tension clamp</b> up to 1 KN, for tensile force tests, clamping width 30 mm, Jaws with pyramid grip	<b>AD 9032</b> € 1080,- 2 pieces
	<b>Screw-in tension clamp</b> up to 2 KN, for tensile force tests, clamping width 20 mm, Jaws with pyramid grip	<b>AD 9031</b> € 972,- 2 pieces
	<b>Screw-in tension clamp</b> up to 2,5 KN, for tensile force tests, clamping width 10 mm, Jaws with pyramid grip	<b>AD 9030</b> € 828,- 2 pieces
	<b>Screw-in tension clamp</b> up to 5 KN, for tensile force tests, clamping width 30 mm, Jaws with pyramid grip	<b>AD 9050</b> € 1494,- 2 pieces
	<b>Screw-in tension clamp</b> up to 5 KN, for tensile force tests, without quick-release lever, clamping width 50 mm, Jaws with pyramid grip	<b>AD 9051</b> € 1710,- 2 pieces

**!** \* ONLY WHILE STOCKS LAST



## For tension tests 500 N – 5000 N



**Screw-in tension clamp**  
up to 5 KN, for tensile force tests,  
with quick-release lever,  
clamping width 50 mm,  
Jaws with pyramid grip

**AD 9052**  
**€ 1980,-**  
2 pieces



**Screw-in tension clamp**  
up to 5 KN, for tensile force tests,  
without quick-release lever,  
clamping width 15 mm,  
Jaws with pyramid grip

**AD 9070**  
**€ 1476,-**  
2 pieces



**Screw-in tension clamp**  
up to 5 KN, for tensile force tests,  
with quick-release lever,  
clamping width 15 mm,  
Jaws with pyramid grip

**AD 9076**  
**€ 1746,-**  
2 pieces



**Wedge tension clamp**  
up to 5 KN, for tensile force tests,  
builds up tensile force automatically  
by its wedge shape, range up  
to 10 mm,  
Jaws with pyramid grip

**AD 9080**  
**€ 2574,-**  
2 pieces



**Rope and thread tension clamps**  
up to 1 KN, Suitable for wires up to a  
diameter of 2 mm, belts up to 7 mm  
wide. incl. jaws with rubberised surface

**AD 9120**  
**€ 900,-**  
2 pieces



**Rope and thread tension clamps**  
up to 5 KN, for clamping belts, ropes,  
wires, etc. Suitable for wires up to a  
diameter of 5 mm, belts up to 8 mm.  
Jaws with pyramid grip

**AD 9121**  
**€ 1440,-**  
2 pieces



**Roller tension clamps**  
up to 1 KN, can clamp on one side and  
eccentrically. suitable for tensile force  
tests with belts or any other soft, flexible,  
flat material with a maximum sample  
thickness of 7 mm, incl. rollers with  
pyramid grip, the opposite clamping  
surface is smooth.  
Suitable for test objects up to 50 mm  
width.

**AD 9205**  
**€ 720,-**  
2 pieces



**Roller tension clamps**  
up to 1 KN, can clamp on one side and  
eccentrically. Suitable for tensile force  
tests with belts or any other soft, flexible,  
flat material with a maximum sample  
thickness of 7 mm, incl. rollers with  
smooth surface, the opposite clamping  
surface is rubberised.  
Suitable for test objects up to 50 mm  
width.

**AD 9206**  
**€ 1098,-**  
2 pieces



**Roller tension clamps**  
up to 5 KN, symmetrisch und exzentrisch  
spannend. Suitable for tensile force tests  
with belts or any other soft, flexible, flat  
material with a maximum sample thickness  
of 7 mm, incl. rollers with pyramid grip

**AD 9200**  
**€ 2556,-**  
2 pieces



**Roller tension clamps**  
up to 5 KN, can clamp on one side and  
eccentrically. Suitable for tensile force  
tests with belts or any other soft, flexible,  
flat material with a maximum sample  
thickness of 7 mm, incl. rollers with  
pyramid grip, the opposite clamping  
surface is smooth.  
Suitable for test objects up to 50 mm  
width.

**AD 9207**  
**€ 1080,-**  
2 pieces



## For tension tests > 5000 N



**Quick clamp**  
for high capacity tensile tests up  
to 30 KN, max. opening: 8 mm,  
Thread: M10

**AC 38**  
**€ 940,-**



**Wedge tension clamp**  
up to 10 KN, for tensile force tests, builds  
up tensile force automatically by its wedge  
shape, clamping width 10 mm,  
Jaws with pyramid grip

**AD 9085**  
**€ 2880,-**  
2 pieces



**Wedge tension clamp**  
up to 10 KN, for tensile force tests, builds  
up tensile force automatically by its wedge  
shape, clamping width 10 mm,  
Jaws with pyramid grip

**AD 9090**  
**€ 3024,-**  
2 pieces



**Wedge tension clamp**  
up to 20 KN, for tensile force tests, builds  
up tensile force automatically by its wedge  
shape, clamping width 13 mm,  
Jaws with pyramid grip

**AD 9095**  
**€ 3420,-**  
2 pieces



**Wedge tension clamp**  
up to 50 KN, for tensile force tests, builds  
up tensile force automatically by its wedge  
shape, clamping width 13 mm,  
Jaws with pyramid grip

**AD 9096**  
**€ 5040,-**  
2 pieces



**Wedge tension clamp**  
up to 20 KN, for tensile force tests, builds  
up tensile force automatically by its wedge  
shape, clamping width 10 mm,  
Jaws with pyramid grip

**AD 9100**  
**€ 4320,-**  
2 pieces



! \* ONLY WHILE STOCKS LAST

All prices listed here are without german legal VAT (19%)

Force measurement accessories

## For tension tests > 5000 N



**Belt tension clamps**  
up to 10 KN, open at one end, suitable for tensile force tests with belts or any other soft, flexible, flat materials with a maximum sample thickness of 2,5 mm a test object width up to 22 mm

**AD 9250**  
**€ 1350,-**  
2 pieces



**Belt tension clamps**  
up to 20 KN, suitable for tensile force tests with belts or any other soft, flexible, flat materials with a maximum sample thickness of 2,5 mm a test object width up to 80 mm

**AD 9255**  
**€ 1800,-**  
2 pieces



**Belt tension clamps**  
up to 50 KN, suitable for tensile force tests with belts or any other soft, flexible, flat materials with a maximum sample thickness of 2,5 mm a test object width up to 80 mm

**AD 9256**  
**€ 3060,-**  
2 pieces



All premium clamps can be customised and, as an option, are available with the following types of jaw finish: **1** undulating, **2** wedge-shaped, **3** pyramid-shaped, **4** smooth or **5** rubberised.

For further information, please contact us or have a look in our webshop at [www.sauter.eu](http://www.sauter.eu)

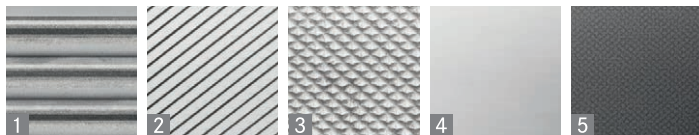

## For compression tests > 500 N



**Concave force sensor**  
with optimised radius for the measurement particularly of arms and legs up to 1 KN, Thread: M6

**AC 45**  
**€ 135,-**



**Flat square-shaped sensor**  
for lateral power sensing of back, chest or arm up to 1 KN, Thread: M6

**AC 46**  
**€ 90,-**



**Round sensor**  
to measure particular muscle groups, such as, for example, the shoulder up to 1 KN, inner thread: M6

**AC 47**  
**€ 95,-**

**!** \* ONLY WHILE STOCKS LAST

## For compression tests > 500 N



**Pressure disc**  
out of aluminium, thickness 10 mm, for compression tests up to 5 KN, diam. 110 mm, outer thread: M10

**AFH 06**  
**€ 50,-**  
2 pieces



**Pressure disc**  
for compression tests up to 5 KN (e. g. plastics), Ø 49 mm, inner thread: M10

**AC 08**  
**€ 55,-**  
2 pieces



**Stainless steel ball-shaped head**  
for compression and fracture tests up to 5 KN, (e.g. foam, glass), Thread: M6/M10

**AC 02**  
**€ 55,-**  
2 pieces



**Bending attachment for bending tests**  
for material tests to detect the bend characteristics. Equipped with mirror to observe the lower side of the material, with three rounded, elongated bending dies Ø 8, 12, 16 mm, mounted to swing freely. Ball bearing bending rollers

**AC 51\***  
**€ 900,-**



**Small 3-point bending device (steel)**  
up to 10 KN, central scale 80-0-80 mm. Consisting of one support beam, two support frames and a curved fin each with permanently fixed radii, radius of the fin 3,2 mm, radii of the support frames 3,2 + 5 mm, other radii on request. Gap between the two support frames 4-150 mm. Width of the brackets 30 mm

**AD 9300**  
**€ 1530,-**



**Small 3-point bending device (anodised aluminium)** up to 2,5 KN, central scale 80-0-80 mm. Consisting of one support beam, two support frames and a curved fin each with permanently fixed radii, radius of the fin 3,2 mm, radii of the support frames 3,2 + 5 mm, other radii on request. Gap between the two support frames 4-150 mm. Width of the brackets 30 mm

**AD 9305**  
**€ 1350,-**



**Small 3-point bending device (steel)**  
up to 10 KN, central scale 80-0-80 mm. Consisting of one support beam, two support frames and a curved fin with interchangeable radii rollers, radius of the fin 5 mm, radii of the support frames 5 + 10 mm, other radii on request. Gap between the two support frames 4-150 mm. Width of the brackets 30 mm

**AD 9310**  
**€ 1530,-**



## For compression tests > 500 N



**Small 3-point bending device (anodised aluminium)** up to 2,5 KN, central scale 80-0-80 mm.  
Consisting of one support beam, two support frames and a curved fin with interchangeable radii rollers, radius of the fin 5 mm, radii of the support frames 5 + 10 mm, other radii on request. Gap between the two support frames 4 – 150 mm. Width of the brackets 30 mm

**AD 9315**  
**€ 1350,-**



## Attachments



**Standard attachments kit**  
for all force gauges FA, FH, FL and FC,  
10 – 500 N

**AC 43**  
**€ 45,-**  
6 items



**Standard attachments kit**  
for force gauge FK  
10 – 500 N

**AC 430**  
**€ 45,-**  
6 items

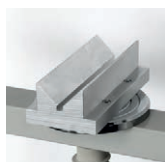

**Box supports made of aluminium,**  
in particular for rectangular packaging  
Suitable for all TVM-N test stands,  
up to 5 KN

**AC 50\***  
**€ 590,-**  
2 pieces

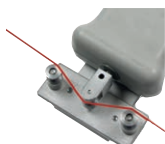

**Tensiometer attachment**  
optional for all FK models from  
FK 10 up to FK 250

**FK-A01**  
**€ 210,-**



**Tensiometer attachment**  
for high-capacity tensile strength  
tests up for FK 500 and FK 1K

**FK-A02**  
**€ 290,-**

## Special solutions



**Stainless steel handle bar**  
with rubber grip for safe handling,  
AFH 04 suitable for FA, FH, FL  
AFK 02 suitable for FK

**AFH 04**  
**€ 85,-**

**AFK 02**  
**€ 85,-**



**Stainless steel handle bar**  
with rubber grip for FH with  
external sensor

**AFH 05**  
**€ 55,-**

## Special solutions



**Door tester**  
Handle (length: 300 mm) and two round  
force receptor plates (Ø 85 mm) as an  
option to FH 1K up to FH 5K for the safe  
testing of clamping forces (not approved  
to DIN 18650 or similar), up to 5 KN

**AFH 03**  
**€ 295,-**



**Tombstone tester**  
for testing the stability of tombstones  
according to VSG 4.7 up to 500 N on  
the basis of FA (included),  
Option: ISO calibration  
961-161, **€ 135,-**

**FA 500G**  
**€ 315,-**



**Tombstone tester**  
for testing the stability of tombstones  
according to VSG 4.7 on the basis of FL,  
up to 500 N: FL 500G  
up to 1.000 N: FL 1KG  
Option: ISO calibration for  
FL 500G: 961-161, **€ 135,-**  
FL 1KG: 961-162, **€ 165,-**

**FL 500G**  
**€ 650,-**

**FL 1KG**  
**€ 720,-**



**Tombstone tester**  
for testing the stability of tombstones  
according to VSG 4.7  
up to 500 N, on the basis of FH  
up to 500 N: FH 500G  
Option: ISO calibration  
961-161, **€ 135,-**

**FH 500G**  
**€ 425,-**

## Interface cables



**RS 232 C PC connection cable**  
from FH devices to PC as spare part

**FH-A01**  
**€ 46,-**



**RS-232 to USB converter**  
suitable for all balances and measuring  
instruments with RS-232 output,  
length about 0,95 m

**AFH 12**  
**€ 85,-**

## Other



**Carrying strap**  
for easy and safe transportation  
of the tombstone tester during  
the testings

**AC 35**  
**€ 50,-**



**Relais module**  
Serves to amplify the output signal of  
the FH dynamometer to control direct  
actions

**AFH 02**  
**€ 340,-**

! \* ONLY WHILE STOCKS LAST

All prices listed here are without german legal VAT (19%)

Force measurement accessories

29





“ Here at SAUTER we know the high demands you make on your bench scales in the various fields of industry, production and quality assurance. We have therefore developed multi-talented products which will help to make your tasks easier to handle each day and meet your requirements for accuracy and quality.

”

*Dietmar Paul, SAUTER Product management  
Stefan Rothmund, Technical service SAUTER*



0,15 Nm



## 02 Torque measurement

There is a fundamental differentiation here between the measurement of static and dynamic rotary forces.

Dynamic rotary force measurement is typically carried out using torque sensors on test objects which are rotated – when the item is moving.

Static rotary force measurement, on the other hand, is always carried out when the item is not in use.

The SAUTER range has just one static torque device for determining the force expended when opening rotary or screw caps on bottles.

Further typical applications of static torque measuring devices are testing of assembly tools for screws and nuts, in particular torque keys and mechanical assembly tools such as cordless electric screw drivers.



**Irmgard Russo**  
Product specialist Torque measurement

Tel. +49 [0] 7433 9933-208  
Fax +49 [0] 7433 9933-29208  
russo@kern-sohn.com

### Quick-Finder

Readout [d] Nm	Measuring range [Max] Nm	Model  SAUTER	Price excl. VAT, ex works €	Page
0,0001	0.5	DB 0.5-4	1690,-	33
0,0002	1	DB 1-4	1690,-	33
0,0002	1	DA 1-4	1890,-	32
0,001	5	DB 5-3	1690,-	33
0,001	5	DA 5-3	1890,-	32
0,002	10	DB 10-3	1690,-	33
0,002	10	DA 10-3	1890,-	32
0,005	20	DB 20-3	1890,-	33
0,01	50	DB 50-2	1890,-	33
0,02	100	DB 100-2	1890,-	33
0,05	200	DB 200-2	1890,-	33
0,05	500	DA 500-2	1890,-	33

NEW



## Comfortable testing of screw tops, e.g. bottles

### Features

- **1 Ideal for torque testing** of bottles and other packaging with screw tops
- **2 Quick pin system:** The four bottle mounts (holders) are pushed in, instead of being screwed in, to save time. This allows you to reconfigure quickly for other bottle sizes
- **Metal housing** for continuous use in tough environmental conditions
- **3 Capacity display:** A bar lights up to show how much of the measuring range is still available.
- **LCD graphics display** with backlight
- **Rubber feet with anti-slip feature**
- Scope of delivery: four bottle mounts with rubber coat, sturdy carry case
- **Internal data memory** saves up to 500 measurements. The memory contents can be transferred to the PC using optional software
- **4 USB and RS-232** data interfaces included

- **Peak hold function** to capture the peak value or **Track function** for continuous display of measurement
- Can be used in both directions of rotation
- **Function to set limits**, programming of Max./Min., with output of acoustic and optical signal. Ideal mode for efficient and accurate testing of standard parts
- **AUTO-OFF function**

### Technical data

- Units can be selected: Nm, lbf-in, kgf-cm, kgf-m, ft-lbf
- Precision:  $\pm 0,5\%$  of [Max]
- Measuring frequency: 1000 Hz
- Usable measuring range: 5 – 100 % of [Max]
- Overload protection: 150 % of [Max]
- Rechargeable battery pack integrated, standard, operating time up to 18 h without backlight, charging time approx. 14 h
- Overall dimensions WxDxH 250x160x100 mm
- Net weight approx. 3 kg

### Accessories

- **Torque-time data transfer software** for data transfer to PC, please ask for details, SAUTER AFH FAST, € 115,-

STANDARD



OPTION



Model	Measuring range [Max] Nm	Readout [d] Nm	Diameter test object mm	Price excl. of VAT of works €	Option ISO Calibration Certificate	
					ISO KERN	€
SAUTER DA 1-4	1	0,0002	10 – 165	1890,-	961-120	170,-
DA 5-3	5	0,001	10 – 165	1890,-	961-120	170,-
DA 10-3	10	0,002	10 – 165	1890,-	961-120	170,-

# Digital torquemeter SAUTER DB

**NEW** **PREMIUM** ★★★



02

## Convenient way to test the torque of tools

### Features

- **1** Particularly suitable for testing torque wrenches, electric hand screwdrivers and cordless screwdrivers
- **2** **Torque pick-up system** for dynamic testing of electric screwdrivers
- **Metal housing** for continuous use in tough environmental conditions
- **3** **Capacity display:** A bar lights up to show how much of the measuring range is still available.
- **LCD graphics display** with backlight
- **Rubber feet with anti-slip feature** at SAUTER DB 0.5-4 up to DB 10-3
- **Stable mounting plate** for solid fixation at SAUTER DB 20-3 up to DB 500-2
- **USB and RS-232** data interfaces included
- **Scope of delivery:** Torque pick-up, sturdy carry case, mounting plate (models with [Max] ≥ 20 Nm)
- **Internal data memory** saves up to 500 measurements. The memory contents can be transferred to the PC using optional software
- **Peak hold function** to capture the peak value or **Track function** for continuous display of measurement
- Can be used in both directions of rotation
- **Function to set limits**, programming of Max./Min., in pull and push direction, with output of acoustic and optical signal. Ideal mode for efficient and accurate testing of standard parts
- **AUTO-OFF function**

### Technical data

- **3** Backlit LCD graphics display
- Units can be selected: Nm, lbf-in, kgf-cm, kgf-m, ft-lbf
- Precision: ± 0,5 % of [Max]
- Measuring frequency: 1000 Hz
- Usable measuring range: 5 – 100 % of [Max]
- Overload protection: 150% of [Max]
- Rechargeable battery pack integrated, standard, operating time up to 18 h without backlight, charging time approx. 14 h
- Overall dimensions WxDxH 200x100x50 mm
- Net weight approx. 3 kg

### Accessories

- **Torque-time data transfer software** for data transfer to PC, please ask for details, AFH FAST, € 115,-

STANDARD



OPTION



Model	Measuring range [Max] Nm	Readout [d] Nm	Tool fitting mm/Zoll	Price excl. of VAT of works €	Option ISO Calibration Certificate	
					ISO KERN	€
SAUTER DB 0.5-4	0.5	0,0001	20 mm & 3/8"	1690,-	961-120	170,-
DB 1-4	1	0,0002	20 mm & 3/8"	1690,-	961-120	170,-
DB 5-3	5	0,001	20 mm & 3/8"	1690,-	961-120	170,-
DB 10-3	10	0,002	20 mm & 3/8"	1690,-	961-120	170,-
DB 20-3	20	0,005	20 mm & 3/8"	1890,-	961-120	170,-
DB 50-2	50	0,01	20 mm & 3/8"	1890,-	961-120	170,-
DB 100-2	100	0,02	3/8"	1890,-	961-120	170,-
DB 200-2	200	0,05	1/2"	1890,-	961-120	170,-
DB 500-2	500	0,05	3/4"	1890,-	961-120	170,-

# Test weights class M1

## Class M1 Slotted weights, finely turned brass

Test weight material: Finely turned brass

Container material: Lined plastic



Slotted weight				+	Container		+	DAkkS certificate		=	Package price	
KERN		Tol ± mg	€		KERN	€		KERN	€		KERN	€
347-415	1 g	1,0	14,-		347-030-400	2,-		962-631	15,-			31,-
347-425	2 g	1,2	15,-		347-030-400	2,-		962-632	15,-			32,-
347-435	5 g	1,6	16,-		347-030-400	2,-		962-633	15,-			33,-
347-445	10 g	2,0	19,-		347-030-400	2,-		962-634	15,-			36,-
347-455	20 g	2,5	20,-		347-080-400	2,-		962-635	15,-			37,-
347-465	50 g	3,0	22,-		347-080-400	2,-		962-636	15,-			39,-
347-475	100 g	5,0	25,-		347-090-400	3,-		962-637	16,-			44,-
347-485	200 g	10	30,-		347-090-400	3,-		962-638	16,-			49,-
347-495	500 g	25	48,-		347-110-400	3,-		962-639	16,-			67,-
347-515	1 kg	50	77,-		347-130-400	9,-		962-641	16,-			102,-
347-525	2 kg	100	116,-		347-130-400	9,-		962-642	17,-			142,-
347-535	5 kg	250	216,-		347-140-400	9,-		962-643	17,-			242,-
347-545	10 kg	500	376,-		347-140-400	9,-		962-644	17,-			402,-

## Class M1 Beam bars, finely turned brass, for fixing slotted weights

Beam bar material: Brass, aluminium (347-445-100)



Beam bar					+	DAkkS certificate	
KERN	Size	Largest slotted weight possible	Maximum total load	€		KERN	€
347-445-100*	10 g	100 g	200 g	30,-		962-634	15,-
347-475-100**	100 g	1 kg	2 kg	50,-		962-637	16,-
347-495-100***	500 g	10 kg	20 kg	79,-		962-639	16,-
347-515-100***	1000 g	10 kg	40 kg	118,-		962-641	16,-

## Class M1 Hook weights, finely turned brass

Test weight material: Finely turned brass

Container material: Lined plastic



Hook weight				+	Container		+	DAkkS certificate		=	Package price	
KERN		Tol ± mg	€		KERN	€		KERN	€		KERN	€
347-416	1 g	1,0	12,-		347-030-400	2,-		962-631	15,-			29,-
347-426	2 g	1,2	13,-		347-030-400	2,-		962-632	15,-			30,-
347-436	5 g	1,6	14,-		347-030-400	2,-		962-633	15,-			31,-
347-446	10 g	2,0	15,-		347-050-400	2,-		962-634	15,-			32,-
347-456	20 g	2,5	16,-		347-050-400	2,-		962-635	15,-			33,-
347-466	50 g	3,0	20,-		347-070-400	2,-		962-636	15,-			37,-
347-476	100 g	5	23,-		347-090-400	3,-		962-637	16,-			42,-
347-486	200 g	10	31,-		347-090-400	3,-		962-638	16,-			50,-
347-496	500 g	25	43,-		347-110-400	3,-		962-639	16,-			62,-
347-516	1 kg	50	63,-		347-120-400	3,-		962-641	16,-			82,-
347-526	2 kg	100	104,-		347-130-400	9,-		962-642	17,-			130,-
347-536	5 kg	250	180,-		347-140-400	9,-		962-643	17,-			206,-
347-546	10 kg	500	350,-		-	-		962-644	17,-			367,-

## Newton weights (N)

All hook and slotted weights as well as beam bars are available with N adjustment according to **M1** tolerances, additional price € 8,-. We need to know the location of use and postal code.

**DAkkS calibration certificate for N weights:** identical to DAkkS prices for individual weights **M1**, additional price € 8,-.



360 mm



## 03 Length measurement

Measuring geometric characteristics is one of the most common tests when carrying out material testing. The most well-known tool is the calliper gauge or the micrometer gauge (micrometer).

In this area of measurement, SAUTER confines itself to integrated calliper gauges which can be used in combination with deforming material testing.

Very often, the issue of material testing relates to a force which is exerted in connection with a specific deformation, i.e. expansion or compression of the test item.

In these cases, the force must be measured or recorded in relation to the distance travelled by the test item during the test.

Integrated calliper gauges serve to capture this distance. They are typically fitted in test stands, machines or plant.

As a guide, the following has been assembled as a sample system for a typical material test stand:

- Length measuring device e.g. LB 300-2
- Test stand, e.g. TVM-N
- Fitting to test stand e.g. LB-A02
- Calibration e.g. 961-150
- Data transfer software e.g. AFH-FD
- Force gauges e.g. FH
- Calibration Force gauges e.g. 961-162



**Irmgard Russo**  
Product specialist Length measurement

Tel. +49 [0] 7433 9933-208  
Fax +49 [0] 7433 9933-29208  
russo@kern-sohn.com

### Quick-Finder

Readout [d] mm	Measuring range [Max] mm	Model  SAUTER	Price excl. VAT, ex works €	Page
0,01	200	LB 200-2.	610,-	36
0,01	300	LB 300-2.	630,-	36
0,01	500	LB 500-2.	890,-	36

# Digital length measuring device SAUTER LB



Distance measurement directly in machines or sites with RS-232 interface

## Features

- **Digital sliding calliper with a superior precision** even at high operation speed
- **Easy mounting** to machine tools, conveyer, test stands etc.
- Zeroing, pre-added and pre-reduced length as well as switching the unit can be done manually
- **Data interface RS-232**, standard
- Selectable measuring units: mm, inch

## Technical data

- Dimensions housing WxDxH 77x43x34 mm
- Battery operation, batteries standard (3V CR2032)

## Accessories

- **Interface cable**, SAUTER LB-A01, € 360,-
- **Mounting the length measuring device** onto a SAUTER test stand at the factory, SAUTER LB-A02, € 190,-

### STANDARD



### OPTION



Model	Measuring range [Max] mm	Readout [d] mm	Direction of measurement	Price excl. of VAT of works €	Option ISO Calibration Certificate	
					ISO KERN	€
SAUTER LB 200-2.	200	0,01	vertical	610,-	961-150	120,-
LB 300-2.	300	0,01	vertical	630,-	961-150	120,-
LB 500-2.	500	0,01	vertical	890,-	961-150	120,-

Price reduction



# WE WEIGH ALMOST EVERYTHING ... AND THAT'S NOT ALL!

## Microscopes and Refractometers

We offer you a complete, carefully-designed range of biological microscopes, stereo microscopes, metallurgical microscopes, polarisation microscopes as well as analogue and digital refractometers which are high-quality and highly-competitive in terms of price.

Comprehensive product details, high-quality materials, durability and ergonomic operation are all in line with the typical KERN "virtues" – quick delivery, large stocks, competent advice, comprehensive pre- and after sales service.



*Your personal copy is ready and waiting for you – you can request it now, free of charge!*



*Request your personal copy!*

## Medical Scales

For years an established name in doctors' surgeries, nursing homes, rehabilitation clinics and hospitals.

Wherever reliable quality is important, look no further than the complete KERN range of medical scales, from baby scales, to personal scales, chair scales, obesity scales through to hand grip dynamometers.

## KERN weighing technology

The KERN weighing technology range covers a large selection of counting scales, platform scales, floor scales, pallet truck scales, crane scales as well as precision balances, analytical balances and moisture analysers.



*Request your personal copy now, free of charge!*



11  $\mu\text{m}$



## 04 Coating thickness measurement

Measurement of coating thicknesses is known from, for example, the paint measurement for coating thickness at cars. In fact, these measurements are used much more widely in industrial applications. This is where the thickness of the surface finish is measured, such as galvanisation, zinc coating etc, or also lacquers.

Fundamentally there are two measuring principles for determining coating thickness:

 **Typ F:** Non-magnetic coatings on magnetic metals, such as iron or steel (magnetic induction principle). Here are some sample material combinations:

- <sup>1)</sup> [aluminium, chrome, copper, rubber, lacquer] on
- <sup>2)</sup> [steel, iron, alloys, magnetic s tainless steel]

 **Typ N:** Non-magnetic coatings on non-magnetic metals, such as aluminium (eddy current principle). Here are some sample material combinations:

- <sup>3)</sup> [lacquer, paints, enamel, chrome, plastics] on
- <sup>4)</sup> [aluminium, brass, sheet metal, copper, zinc, bronze]

 **Typ FN:** All coatings as for type F and N on all metals as for type F and N (combination of magnetic induction and eddy current principle)

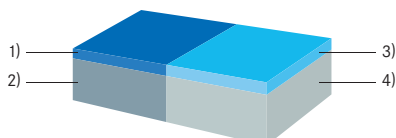

**Taras Mikitisin**

Product specialist

Coating thickness measurement

Tel. +49 [0] 7433 9933-143

Fax +49 [0] 7433 9933-29143

mikitisin@kern-sohn.com

### Quick-Finder

Readout [d] $\mu\text{m}$	Measuring range [Max] $\mu\text{m}$	Model  SAUTER	Price excl. VAT, ex works €	Page
0,1   1	100   1000	TB 1000-0.1F.	320,-	39
0,1   1	100   1000	TB 1000-0.1N.	360,-	39
0,1   1	100   1000	TB 1000-0.1FN.	400,-	39
0,1   1	100   1250	TC 1250-0.1F.	360,-	40
0,1   1	100   1250	TC 1250-0.1N.	400,-	40
0,1   1	100   1250	TC 1250-0.1FN.	460,-	40
0,1   1	100   1250	TC 1250-0.1FN-CAR.	470,-	40
0,1   1	100   1250	TE 1250-0.1F.	360,-	41
0,1   1	100   1250	TE 1250-0.1N.	400,-	41
0,1   1	100   1250	TE 1250-0.1FN.	460,-	41
0,1   1	100   1250	TF 1250-0.1FN.	530,-	42
0,1   1	100   1250	TG 1250-0.1FN.	530,-	42
0,1   1	100   2000	TJ 2000-0.1F.	290,-	39
-	-	TJ	580,-	43



# Digital coating thickness gauge SAUTER TB



Your reliable worktool for every day: light, easy, precise

## Features

- **External sensor** for difficult-to-access measurements
- **Base plate and calibration foils** included
- Delivered in a hard carrying case
- **Offset-Accur:** This function allows you to adjust the instrument precisely on the locally measured range by a two-point calibration. This results in a superior accuracy of approx. 1 % of the measured value
- SAUTER TB 2000-0.1F: Specifically designed for the automobile industry, Precision: Standard 5 % of measured value
- Selectable measuring units: mm, µm, mil
- **Auto-Power-Off**

## Technical data

- Precision:
  - Standard: 3 % of measured value
  - Offset-Accur: 1 % of measured value
- Minimal measuring area: 6 mm
- Minimal base thickness: 0,3 mm
- Dimensions WxDxH 69x32x161 mm
- Battery operation, batteries standard 4 x 1.5 V AA
- Net weight approx. 0,26 kg

## Accessories

- **2 Calibration foils** for increased measuring accuracy (covers the range from 20 up to 2000 µm, with < 3 % tolerance), sim. to illustration, SAUTER ATB-US07, € 105,-
- **Sensor, Type F, SAUTER ATE 01, € 105,-**
- **Sensor, Type N, SAUTER ATE 02, € 110,-**

### STANDARD



### OPTION



Model	Measuring range [Max] µm	Readout [d] µm	Test object	Smallest sample surface (radius) mm	Price excl. of VAT ex works €	Option ISO Calibration Certificate	
						ISO KERN	€
SAUTER TB 1000-0.1F.	100   1000	0,1   1	Coatings on steel and iron (F)	F: Convex: 1,5 Concave: 25	320,-	961-110	120,-
SAUTER TB 1000-0.1N.	100   1000	0,1   1	Insulating coatings on non-magnetic metals (N)			N: Convex: 3 Concave: 50	360,-
SAUTER TB 1000-0.1FN.	100   1000	0,1   1	Combination instrument: F/N		400,-		
SAUTER TB 2000-0.1F.	100   2000	0,1   1	Non-magnetic coatings on iron, steel (F)		290,-	961-110	120,-

# Digital coating thickness gauge SAUTER TC



Your constant companion – compact and easy to use

## Features

- Ergonomic design for easy handling
- **Data interface RS-232**, included
- **Base plate and calibration foils** included
- Delivered in a hard carrying case
- **Offset-Accur:** This function allows you to adjust the instrument precisely on the locally measured range by a two-point calibration. This results in a superior accuracy of approx. 1 % of the measured value
- Selectable measuring units:  $\mu\text{m}$ , mil

## 1 SAUTER TC 1250-0.1FN-CAR:

- Specifically designed for the automobile industry
- **Automatic recognition of measuring mode** (F or N): "point and shoot"
- **Simple and convenient 1-key operation**

## Technical data

- Precision:
  - Standard: 3 % of measured value or  $\pm 2,5 \mu\text{m}$
  - Offset-Accur: 1 % of measured value or  $\pm 1 \mu\text{m}$
- Minimal base thickness: 0,3 mm
- Dimensions WxDxH 65x28x131 mm
- Battery operation, batteries standard  
4 x 1.5 V AAA
- Net weight approx. 81 g

## Accessories

- **Software**, interface cable included, SAUTER ATC-01, € 90,-
- **Calibration foils** for increased measuring accuracy (covers the range from 20 up to 2000  $\mu\text{m}$ , with < 3 % tolerance), SAUTER ATB-US07, € 105,-

### STANDARD



### OPTION



Model	Measuring range [Max] $\mu\text{m}$	Readout [d] $\mu\text{m}$	Test object	Smallest sample surface (radius) mm	Price excl. of VAT ex works €	Option ISO Calibration Certificate	
						ISO KERN	€
SAUTER TC 1250-0.1F.	100   1250	0,1   1	Coatings on steel and iron (F)	F: Convex: 1,5 Concave: 25	360,-	961-110	120,-
TC 1250-0.1N.	100   1250	0,1   1	Insulating coatings on non-magnetic metals (N)	N: Convex: 3 Concave: 50	400,-	961-110	120,-
TC 1250-0.1FN.	100   1250	0,1   1	Combination instrument: F/N		460,-	961-112	170,-
TC 1250-0.1FN-CAR.	100   1250	0,1   1	Combination instrument: F/N		470,-	961-112	170,-

# Digital coating thickness gauge SAUTER TE



Ergonomic design and external sensor for highest ease of use

## Features

- **External sensor** for difficult-to-access measurements
- **Data interface RS-232**, included
- **Base plate and calibration foils** included
- **Delivered in a hard carrying case**
- **Offset-Accur:** This function allows you to adjust the instrument precisely on the locally measured range by a two-point calibration. This results in a superior accuracy of approx. 1 % of the measured value
- Selectable measuring units:  $\mu\text{m}$ , mil
- **Auto-Power-Off**

## Technical data

- Precision:
  - Standard: 3 % of measured value or  $\pm 2,5 \mu\text{m}$
  - Offset-Accur: 1 % of measured value or  $\pm 1 \mu\text{m}$
- Minimal base thickness: 0,3 mm
- Dimensions WxDxH 65x28x131 mm
- Battery operation, batteries standard 4 x 1.5 V AAA
- Net weight approx. 81 g

## Accessories

- **Data transfer software**, interface cable included, SAUTER ATC-01, **€ 90,-**
- **Calibration foils** for increased measuring accuracy (covers the range from 20 up to 2000  $\mu\text{m}$ , with < 3 % tolerance), SAUTER ATB-US07, **€ 105,-**
- **Sensor, Typ F**, SAUTER ATE-01, **€ 105,-**
- **Sensor, Typ N**, SAUTER ATE-02, **€ 110,-**

### STANDARD



### OPTION



Model	Measuring range [Max] $\mu\text{m}$	Readout [d] $\mu\text{m}$	Test object	Smallest sample surface (radius) mm	Price excl. of VAT ex works €	Option ISO Calibration Certificate	
						ISO KERN	€
SAUTER TE 1250-0.1F.	100   1250	0,1   1	Coatings on steel and iron (F)	F: Convex: 1,5 Concave: 25	<b>360,-</b>	961-110	120,-
TE 1250-0.1N.	100   1250	0,1   1	Insulating coatings on non-magnetic metals (N)	N: Convex: 3 Concave: 50	<b>400,-</b>	961-110	120,-
TE 1250-0.1FN.	100   1250	0,1   1	Combination instrument: F/N		<b>460,-</b>	961-112	170,-

# Coating thickness gauges SAUTER TF · TG

PREMIUM  
★★★



PREMIUM  
★★★



## 04 SAUTER TF

## SAUTER TG

Premium measuring devices for paint coating, lacquer coating etc.

### Features

- **LCD display**, backlit, display of all information at a glance
- **Offset-Accur:** This function allows you to adjust the instrument precisely on the locally measured range by a two-point calibration. This results in a superior accuracy of approx. 1 % of the measured value
- **Scan mode** allows continuous measurement or single point measuring mode
- **Mini Statistics Kit:** displays the measured result, the average value and the max and the min value
- **Internal memory** up to 99 values
- Selectable measuring units:  $\mu\text{m}$ , mil
- **Base plate and calibration foils** included
- **Data interface RS-232** standard
- Delivered in a hard carrying case

### SAUTER TG:

- **External sensor** for difficult-to-access measurements

### Technical data

- Precision:
  - Standard: 3 % of measured value or  $\pm 2,5 \mu\text{m}$
  - Offset-Accur: 1 % of measured value or  $\pm 1 \mu\text{m}$
- Minimal base thickness: 0,3 mm
- Dimensions WxDxH 65x35x126 mm
- Battery operation, batteries standard 2 x 1.5 V AAA
- Net weight approx. 81 g

### Accessories

- **Software**, interface cable included, SAUTER ATC-01, € 90,-
- **Calibration foils** for increased measuring accuracy (covers the range from 20 up to 2000  $\mu\text{m}$ , with < 3 % tolerance), SAUTER ATB-US07, € 105,-
- **External sensor**, Type FN, for TG, SAUTER ATG 01, € 130,-

### STANDARD

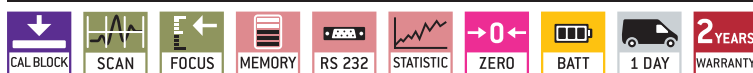

### OPTION



Model	Measuring range [Max] $\mu\text{m}$	Readout [d] $\mu\text{m}$	Test object	Smallest sample surface (radius) mm	Price excl. of VAT ex works €	Option ISO Calibration Certificate	
						ISO KERN	€
SAUTER TF 1250-0.1FN.	100   1250	0,1   1	Combination instrument: F/N	F: Convex: 1,5 Concave: 25	530,-	961-112	170,-
SAUTER TG 1250-0.1FN.	100   1250	0,1   1	Combination instrument: F/N	N: Convex: 3 Concave: 50	530,-	961-112	170,-



# Manual test stand SAUTER TJ

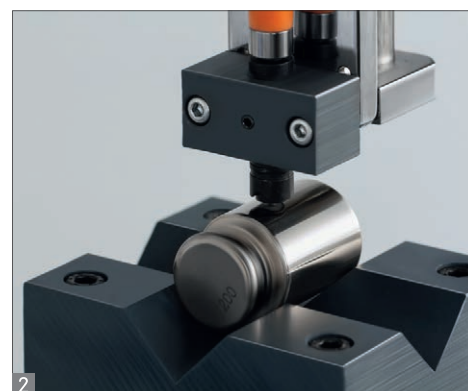
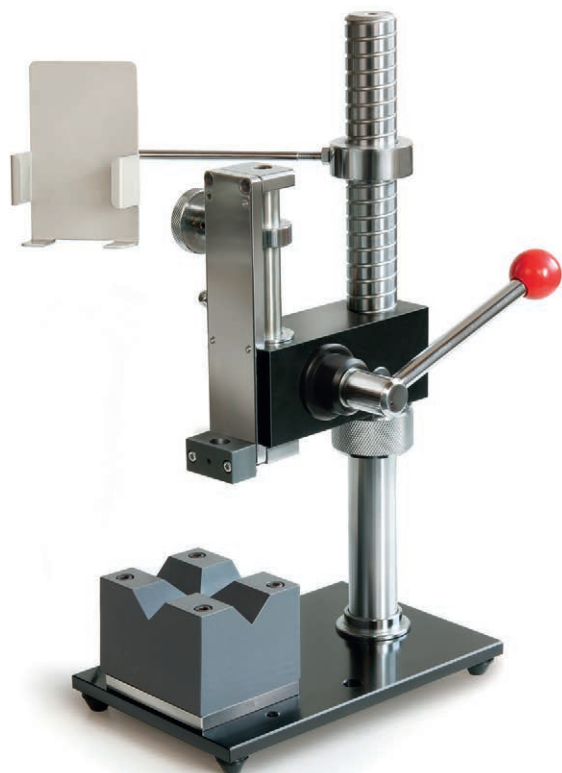

## Lever test stand for measuring the thickness of layers, in particular of round objects

### Features

- Suitable for all SAUTER measuring devices for layer thickness with external measuring head, such as SAUTER TG 1250-0.1FN. (not included)
- Serves to increase the measurement precision by means of controlled handling
- In particular with round objects, this test stand, with its contoured bracket, offers a more secure base for more accurate measuring results
- Layer thickness measurements are typically carried out to an accuracy level of 1 µm, which is 0.001 mm. When doing this, slight movements or changes in angle when guiding the sensor can cause significant distortion of the measuring result

- These distortions are often unavoidable and can only be compensated by repeating the operation many times
- The SAUTER lever test stand TJ guarantees reliable measurements because the measuring head is guided properly
- Your advantage: The bracket for the measuring head is fitted with two separate screws
- Furthermore, for the SAUTER measuring device for layer thickness with external sensors, the spring function for sensor security can be kept in the test stand – if adjusted precisely

### Technical data

- Maximum test object height: 300 mm
- Overall dimensions WxDxH 150x233x420 mm
- Net weight approx. 10,5 kg

STANDARD



Model	Maximum carriage height above base plate	Price excl. of VAT ex works €
SAUTER	mm	
TJ	318	580,-

ONLY WHILE STOCKS LAST!

For more information, please visit [www.sauter.eu/en/TJ](http://www.sauter.eu/en/TJ) · Order hotline +49 [0] 7433 9933-0

30 mm



## 05 Wall thickness measurement

In cases, when the walls of the item to be measured are not accessible for traditional calliper gauges, the ultrasonic measuring equipment can be used.

This measurement is based on the following principle: Ultrasonic waves are directed onto one side of the material to be measured. They move with a defined speed through the material and are reflected on the other side. The measuring device measures the time required to do this and with this, calculates the thickness of the material.

In this way the wall thickness of, for example, ship's hulls, pipes, tanks and components in sites or machines can be determined.

Ultrasonic measuring equipment can be used to measure all hard and homogeneous materials, such as metal, glass and hard plastics. This method cannot be used to measure materials such as concrete, asphalt or wood.



**Taras Mikitsin**  
Product specialist  
Wall thickness measurement

Tel. +49 [0] 7433 9933-143  
Fax +49 [0] 7433 9933-29143  
mikitsin@kern-sohn.com

### Quick-Finder

Readout [d] mm	Measuring range [Max] mm	Model  SAUTER	Price excl. VAT, ex works €	Page
0,01	30	TN 30-0.01EE	1200,-	49
0,01	60	TN 60-0.01EE	1650,-	49
0,01	80	TU 80-0.01US.	1170,-	50
0,01	80	TN 80-0.01US.	620,-	48
0,01	225	TD GOLD 40.	450,-	47
0,01	230	TU 230-0.01US.	1170,-	50
0,01	300	TU 300-0.01US.	1260,-	50
0,01   0,1	230	TN 230-0.01US.	620,-	48
0,01   0,1	300	TN 300-0.01US.	710,-	48
0,1	80	TN 80-0.1US.	560,-	48
0,1	200	TB 200-0.1US.	320,-	45
0,1	200	TB 200-0.1US-RED.	270,-	45
0,1	225	TD 225-0.1US.	370,-	46
0,1	230	TN 230-0.1US.	560,-	48
0,1	300	TN 300-0.1US.	660,-	48

# Ultrasonic thickness gauge SAUTER TB-US



## Compact worktool for daily use

### Features

- **External sensor** for difficult-to-access measurements
- **Base plate for adjustment** incorporated
- **Delivered in a hard carrying case**
- **Auto-Power-Off**
- Selectable measuring units: mm, inch
- TB 200-0.1US-RED. can only analyse these materials: cast iron, aluminium, copper, brass, zinc, quartz glass, polyethylene, PVC, grey cast iron, nodular cast iron, steel

### Technical data

- Precision: 0,5 % of [Max]
- Dimensions WxDxH 69x32x161 mm
- Battery operation, batteries standard 4 x 1.5 V AA
- Net weight approx. 0,3 kg

### Accessories

- **External sensor**, 5 MHz, Ø 6 mm, for thin test materials: measuring range (steel) 1 – 50 mm, SAUTER ATB-US01, **€ 190,-**
- **External sensor**, 5 MHz, Ø 12 mm, for hot test materials: Measuring range (steel) 1 – 225 mm at normal temperatures, 4 – 100 mm at temperatures of up to 300 °C, SAUTER ATB-US02, **€ 295,-**
- **External sensor**, 7 MHz, Ø 6 mm, for thin test materials: Measuring range 0,75 – 80 mm (steel), SAUTER ATU-US02, **€ 110,-**
- **External sensor**, 5 MHz, Ø 10 mm, SAUTER ATU-US09, **€ 110,-**
- **External sensor**, 5 MHz, Ø 8 mm, SAUTER ATB-US06, **€ 100,-**
- **Ultrasound contact gel**, standard, can be reordered, approx. 60 ml, SAUTER ATB-US03, **€ 30,-**
- **5 steel calibration blocks** without wooden box, SAUTER ATU-06, **€ 560,-**
- **5 steel calibration blocks** with wooden box, SAUTER ATU-09, **€ 975,-**

#### STANDARD



#### OPTION



Model	Measuring range [Max] mm	Readout [d] mm	Sensor	Sound velocity m/sec	Price excl. of VAT ex works €	Option ISO Calibration Certificate	
						ISO KERN	€
SAUTER TB 200-0.1US.	1,5 - 200	0,1	5 MHz   Ø 8 mm	500 - 9000	<b>320,-</b>	961-113	120,-
SAUTER TB 200-0.1US-RED.	1,5 - 200	0,1	5 MHz   Ø 8 mm	-	<b>270,-</b>	961-113	120,-

# Ultrasonic thickness gauge SAUTER TD-US



## Compact material thickness gauge with external sensor

### Features

- **External sensor** for difficult-to-access measurements
- **Data interface RS-232** included
- **Base plate for adjustment** incorporated
-  Delivered in a hard carrying case
- Selectable measuring units: mm, inch

### Technical data

- Precision: 0,5 % of [Max] + 0,1 mm
- Dimensions WxDxH 120x65x30 mm
- Battery operation, batteries standard 4 x 1.5 V AAA, AUTO-OFF function to preserve the batteries
- Net weight approx. 0,164 kg

### Accessories

- **Software**, interface cable included, SAUTER ATD-01, **€ 90,-**
- **External sensor**, 6 MHz, Ø 6 mm, for thin test materials: Measuring range (steel) 1 – 50 mm, SAUTER ATB-US01, **€ 190,-**
- **External sensor**, 5 MHz, Ø 12 mm, for hot test materials: Measuring range (steel) 1 – 225 mm at normal temperatures, 4 – 100 mm at temperatures of up to 300 °C, SAUTER ATB-US02, **€ 295,-**
- **External sensor**, 7 MHz, Ø 6 mm, SAUTER ATU-US02, **€ 110,-**
- **External sensor**, 5 MHz, Ø 10 mm, SAUTER ATU-US09, **€ 110,-**
- **External sensor**, 5 MHz, Ø 10 mm, transducer at an angle of 90°, SAUTER ATU-US10, **€ 110,-**
- **Ultrasound contact gel**, standard, can be reordered, approx. 60 ml, SAUTER ATB-US03, **€ 30,-**
- **5 steel calibration blocks** without wooden box, SAUTER ATU-06, **€ 560,-**
- **5 steel calibration blocks** with wooden box, SAUTER ATU-09, **€ 975,-**

#### STANDARD



#### OPTION



Model	Measuring range [Max] mm	Readout [d] mm	Sensor	Sound velocity m/sec	Price excl. of VAT ex works €	Option ISO Calibration Certificate	
						ISO KERN	€
SAUTER TD 225-0.1US.	1,2 - 225	0,1	5 MHz   Ø 8 mm	500 - 9000	<b>370,-</b>	961-113	120,-



# Gold tester SAUTER TD-GOLD

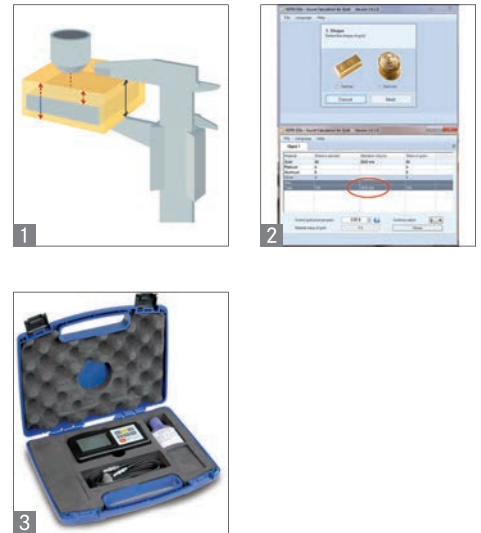

## Ultrasound measuring instrument for testing the authenticity of gold and silver

### Features

- You can use the TD-GOLD to determine whether gold or silver bars and coins are genuine or whether they contain a core of a different material
- The instrument measures the thickness of gold bars and gold coins using ultrasound
- 1** Process: Ultrasound waves are directed onto the test object using a sensor. The waves penetrate the test object, are then reflected from a surface opposite the object and then picked up again by the sensor. The measurement determined by this process will be compared with the material thickness as measured by a traditional calliper gauge. On the basis of the measurement given, false cores (Figure: grey) for example, those made of tungsten, lead, etc. can be easily identified, as the ultrasound reacts differently, compared with pure gold

- 2** Using the SAUTER SSG software (included), you can determine whether the test item is genuine or contains a false core – and you can be very confident of the result
- Known additions in tested gold items – e.g. copper or silver – are compensated by the software
- In addition, the software determines the value of the gold item. The price of gold is polled on line continuously
- It is the only test process which measures right through the whole bar or the whole coin without interference and thereby guarantees the highest level of certainty
- Base plate for adjustment** incorporated
- 3** Delivered in a hard carrying case

### Technical data

- Battery operation, batteries not standard 4 x 1,5 V AAA
- Dimensions WxDxH 120x62x30 mm
- Net weight approx. 0,2 kg
- Permissible ambient temperature 15 °C/35 °C

### Accessories

- Ultrasound contact gel**, standard, can be reordered, approx. 60 ml, SAUTER ATB-US03, € 30,-

#### STANDARD



#### OPTION



Model	Measuring range (steel) [Max] mm	Measuring range (gold) [Max] mm	Readout [d] mm	Sensor	Price excl. of VAT ex works €	Option ISO Calibration Certificate	
						ISO KERN	€
TD GOLD 40.	225	40	0,01	5 MHz   6 mm	450,-	961-113	120,-

# Ultrasonic thickness gauge SAUTER TN-US



## Portable measuring device for ultrasonic material thickness testing

### Features

- **External sensor**
- **Data interface USB**, standard (only for models with readout [d] = 0,01 mm)
- Delivered in a hard carrying case
- **Scan mode** (10 measurements per sec.) or single point measuring mode possible
- **Internal memory** for up to 20 files (with up to 100 values per file)
- Selectable measuring units: mm, inch

### Technical data

- Precision: 0,5 % of [Max] ± 0,04 mm
- Dimensions WxDxH 74x32x150 mm
- Battery operation, batteries standard 2 x 1.5 V AA, AUTO-OFF function to preserve the batteries
- Net weight approx. 245 g

### Accessories

- **Software**, interface cable included, SAUTER ATU-04, € 100,-
- **External sensor**, 2,5 MHz, Ø 14 mm, for thick samples, in particular cast iron with rough upper surfaces: Measuring range 3 - 300 mm (steel), SAUTER ATU-US01, € 215,-

- **External sensor**, 7 MHz, Ø 6 mm, for thin test materials: Measuring range 0,75 - 80 mm (steel), SAUTER ATU-US02, € 110,-
- **External sensor**, 5 MHz, Ø 12 mm, for hot test materials: Measuring range (steel) 3 - 200 mm at temperatures of up to 300 °C, SAUTER ATB-US02, € 295,-
- **External sensor**, 5 MHz, Ø 10 mm, SAUTER ATU-US09, € 110,-
- **External sensor**, 5 MHz, Ø 10 mm, transducer at an angle of 90°, SAUTER ATU-US10, € 110,-
- **Ultrasound contact gel**, standard, can be reordered, approx. 60 ml, SAUTER ATB-US03, € 30,-
- **5 steel calibration blocks** without wooden box, SAUTER ATU-06, € 560,-
- **5 steel calibration blocks** with wooden box, SAUTER ATU-09, € 975,-

#### STANDARD



#### OPTION



Model	Measuring range	Readout	Sensor	Sound velocity	Price excl. of VAT ex works €	Option ISO Calibration Certificate	
						ISO KERN	€
SAUTER	[Max] mm	[d] mm		m/sec			
TN 80-0.1US.	0,75 - 80	0,1	7 MHz   Ø 6 mm	1000 - 9999	560,-	961-113	120,-
TN 230-0.1US.	1,2 - 230	0,1	5 MHz   Ø 10 mm	1000 - 9999	560,-	961-113	120,-
TN 300-0.1US.	3 - 300	0,1	2,5 MHz   Ø 14 mm	1000 - 9999	660,-	961-113	120,-
TN 80-0.01US.	0,75 - 80	0,01	7 MHz   Ø 6 mm	1000 - 9999	620,-	961-113	120,-
TN 230-0.01US.	1,2 - 200   230	0,01   0,1	5 MHz   Ø 10 mm	1000 - 9999	620,-	961-113	120,-
TN 300-0.01US.	3 - 200   300	0,01   0,1	2,5 MHz   Ø 14 mm	1000 - 9999	710,-	961-113	120,-

# Ultrasonic thickness gauges SAUTER TN-EE

PREMIUM  
★ ★ ★



Portable measuring device for ultrasonic material thickness testing in Echo-Echo principle

## Features

- **External sensor**
- **Data interface RS-232**, standard
- Delivered in a hard carrying case
- **Scan mode** (10 measurements per sec.) or single point measuring mode possible
- **Internal memory** for up to 20 files (with up to 100 values per file)
- Selectable measuring units: mm, inch
- Two measuring modes to determine material thickness:
  - Pulse-echo mode
  - Echo-echo mode
- Determining the actual thickness of materials regardless of any coating which might be present. In this way, the wall thickness of pipes, for example can be determined in a non-destructive manner, i.e. without having to remove the coating
- Echo-echo measurements are only possible with the measuring head included as part of the delivery (ATU-US12, see accessory)

## Technical data

- Precision: 0,5 % of [Max] ± 0,04 mm
- Dimensions WxDxH 74x32x150 mm
- Battery operation, batteries standard 2 x 1.5 V AA, AUTO-OFF function to preserve the batteries
- Net weight approx. 245 g
- Maximum thickness of coating (paints, lacquers or similar coatings which shall be eliminated): 3 mm

## Accessories

- **Software**, interface cable included, SAUTER ATU-04, € 100,-
- **External sensor**, 5 MHz, Ø 12 mm, for echo-echo measuring, SAUTER ATU-US12, € 310,-
- **Ultrasound contact gel**, standard, can be reordered, approx. 60 ml, SAUTER ATB-US03, € 30,-
- **RS-232/USB adapter**, SAUTER AFH 12, € 85,-
- **5 steel calibration blocks** without wooden box, SAUTER ATU-06, € 560,-
- **5 steel calibration blocks** with wooden box, SAUTER ATU-09, € 975,-

### STANDARD



### OPTION



Model	Measuring range Echo-echo	Measuring range Pulse-echo	Readout [d] mm	Sensor	Sound velocity m/sec	Price excl. of VAT ex works €	Option ISO Calibration Certificate	
							ISO KERN	€
SAUTER TN 30-0.01EE	3 - 30	0,65 - 600	0,01	5 MHz   Ø 12 mm	1000 - 9999	1200,-	961-113	120,-
SAUTER TN 60-0.01EE	3 - 60	0,65 - 600	0,01	5 MHz   Ø 12 mm	1000 - 9999	1650,-	961-113	120,-



# Ultrasonic thickness gauge SAUTER TU-US

PREMIUM



## Premium ultrasonic thickness gauge

### Features

- **External sensor** for difficult-to-access measurements
- **Base plate for adjustment** included
- **Data interface RS-232**
- Delivered in a hard carrying case
- **Scan mode** (10 measurements per sec.) or single point measuring mode possible
- **Internal memory** for up to 20 files (with up to 100 values per file)
- **Function to set limits**, programming of Max./Min., in pull and push direction, with output of audible and optical signal.
- Selectable measuring units: mm, inch
- Robust metal housing

### Technical data

- Precision: 0,5 % of [Max] ± 0,04 mm
- Dimensions WxDxH 76x32x132 mm
- Battery operation, batteries standard 2 x 1.5 V AA
- Net weight approx. 345 g

### Accessories

- **Software**, interface cable included, SAUTER ATU-04, € 100,-
- **External sensor**, 2,5 MHz, Ø 14 mm, for thick samples, in particular cast iron with rough upper surfaces: Measuring range 3 - 300 mm (steel), SAUTER ATU-US01, € 215,-
- **External sensor**, 7 MHz, Ø 6 mm, for thin test materials: Measuring range 0,75 - 80 mm (steel), SAUTER ATU-US02, € 110,-

- **External sensor**, 5 MHz, Ø 12 mm, for hot test materials: Measuring range (steel) 3 - 200 mm at temperatures of up to 300 °C, SAUTER ATB-US02, € 295,-
- **External sensor**, 5 MHz, Ø 10 mm, SAUTER ATU-US09, € 110,-
- **External sensor**, 5 MHz, Ø 10 mm, transducer at an angle of 90°, SAUTER ATU-US10, € 110,-
- **External sensor**, 6 MHz, Ø 6 mm, for thin test materials: Measuring range (steel) 1 - 50 mm, SAUTER ATB-US01, € 190,-
- **Thermal printer**, SAUTER ATU-05, € 420,-
- **Paper rolls**, 1 piece, for SAUTER ATU-05, SAUTER ATU-US11, € 15,-
- **Ultrasound contact gel**, standard, can be reordered, approx. 60 ml, SAUTER ATB-US03, € 30,-
- **5 steel calibration blocks** without wooden box, SAUTER ATU-06, € 560,-
- **5 steel calibration blocks** with wooden box, SAUTER ATU-09, € 975,-

STANDARD



OPTION



Model	Measuring range [Max] mm	Readout [d] mm	Sensor	Sound velocity m/sec	Price excl. of VAT ex works €	Option ISO Calibration Certificate	
						ISO KERN	€
SAUTER TU 80-0.01US.	0,75 - 80	0,01	7 MHz   Ø 6 mm	1000 - 9999	1170,-	961-113	120,-
TU 230-0.01US.	1,2 - 230	0,01	5 MHz   Ø 10 mm	1000 - 9999	1170,-	961-113	120,-
TU 300-0.01US.	3 - 300	0,01	2,5 MHz   Ø 14 mm	1000 - 9999	1260,-	961-113	120,-

HX 100



## 06 Hardness testing of plastics (Shore)

To determine the hardness of plastics, in 1915 Albert Shore developed an extremely simple process: A pin made of hardened metal and of a defined shape is held by a spring and is then pushed into the test item. Depending on the depth of the penetration, the material tested is either harder or softer. This method has been adopted in the DIN standards 53505 and 7868.

Currently, there are two types of devices used for this test: Mechanical measuring devices with drag indicator and electronic measuring devices.

Both types of measuring devices can be operated with test stands (such as the SAUTER TI series). With a test stand, measurements can be carried out more consistently and accurately.

At this time, KERN does not calibrate Shore hardness testing instruments. As an alternative, we recommend that the measuring device is operated with a calibrated kit of test plates (such as SAUTER AHBA 01).



**Taras Mikitisin**  
Product specialist  
Hardness testing of plastics

Tel. +49 [0] 7433 9933-143  
Fax +49 [0] 7433 9933-29143  
mikitisin@kern-sohn.com

### Quick-Finder

Readout [d] Hx	Measuring range [Max] Hx	Measure- ment	Model  SAUTER	Price excl. VAT, ex works €	Page
1,0 HA	100 HA	A	<b>HBA 100-0.</b>	<b>105,-</b>	52
1,0 HAO	100 HAO	A0	<b>HBO 100-0.</b>	<b>135,-</b>	52
1,0 HD	100 HD	D	<b>HBD 100-0.</b>	<b>140,-</b>	52
1,0 HA	100 HA	A	<b>HDA 100-1.</b>	<b>375,-</b>	53
1,0 HO	100 HO	A0	<b>HDO 100-1.</b>	<b>375,-</b>	53
1,0 HD	100 HD	D	<b>HDD 100-1.</b>	<b>375,-</b>	53
-	-	A0	<b>TI-A0</b>	<b>240,-</b>	54
-	-	D	<b>TI-D.</b>	<b>300,-</b>	54
-	-	A0	<b>TI-A0L</b>	<b>270,-</b>	54
-	-	D	<b>TI-DL</b>	<b>340,-</b>	54

# Analogue Shore hardness tester SAUTER HB



## Compact handheld durometer with drag indicator

### Features

- Typical application: measurement of penetration (Shore)
- Particularly recommended for internal comparison measurement. Standard calibrations e. g. to DIN 53505 are often not possible because of very narrow standard tolerances
- **Shore A** rubber, elastomers, neoprene, silicone, vinyl, soft plastics, felt, leather and similar material
- **Shore D** plastics, formica, epoxides, plexiglass etc.
- **Shore A0** foam, sponge etc.
- **Max mode:** Holds the maximum value in the display
- **Point mode:** Shows one instant value
- Can be attached to the test stands SAUTER TI-A0 (for Shore A and A0), TI-D. (for Shore D)
- Delivered in a wooden carrying case
- The measuring tips are not interchangeable

### Technical data

- Precision: 3 % of [Max]
- Dimensions WxDxH 60x25x115 mm
- Net weight approx. 160 g
- Screws to screw on to the TI: M7 fine thread
- Material thickness of the sample, min. 4 mm

### Accessories

Shore comparison plates for testing and calibration of Shore hardness testing devices. By regular comparisons the measuring accuracy increases significantly.

- **7 hardness comparison plates** for Shore A, tolerance up to  $\pm 2$  H, SAUTER AHBA-01, € 95,-
- **3 hardness comparison plates** for Shore D, tolerance up to  $\pm 2$  HD, SAUTER AHBD-01, € 75,-
- **Optional ISO calibration of the comparison plates**, SAUTER 961-170, € 95,-
- **Test stand** for HBA and HBO, SAUTER TI-A0, € 270,-
- **Test stand** for HBD, SAUTER TI-D., € 300,-

STANDARD



OPTION



Model	Hardness type	Measuring range	Readout	Price excl. of VAT ex works €
		[Max] HS	[d] HS	
SAUTER HBA 100-0.	Shore A	100 HA	1,0 HA	105,-
HBO 100-0.	Shore A0	100 HAO	1,0 HAO	135,-
HBD 100-0.	Shore D	100 HD	1,0 HD	140,-



# Professional Shore hardness tester SAUTER HD



## Professional Shore hardness tester

### Features

- **Shore A, 0 and D** to measure the hardness of plastics through penetration measurement
- **Shore A** rubber, elastomers, neoprene, silicone, vinyl, soft plastics, felt, leather and similar material
- **Shore 0** foam, sponge
- **Shore D** plastics, formica, epoxides, plexiglass etc.
- **Internal memory** for up to 500 measurements
- Delivered in a hard carrying case
- Particularly recommended for internal comparison measurement. Standard calibrations e. g. to DIN 53505 are often not possible because of very narrow standard tolerances
- Can be attached to the test stands TI-A0L (for Shore A and A0), TI-DL (for Shore D) to improve measuring uncertainty
- Large display with backlight
- Selectable: AUTO-OFF function or continuous operation, charge indicator

### Technical data

- Tolerance: 1 % of [Max]
- Overall dimensions WxDxH 162x65x38 mm
- Net weight approx. 173 g
- Permissible ambient temperature 0 °C/50 °C
- Transfer via RS-232 to the PC, e.g. to Microsoft Excel
- Measuring frequency: 30 display updates per minute
- Battery operation, batteries standard 2 x 1.5 V AAA
- Material thickness of the sample, min. 4 mm

### Accessories

- **Software**, interface cable included, SAUTER ATC-01, € 90,-
- **1 7 hardness comparison plates** for Shore A, tolerance up to ± 2 H, SAUTER AHBA-01, € 95,-
- **2 3 hardness comparison plates** for Shore D, tolerance up to ± 2 HD, SAUTER AHBD-01, € 75,-
- **Optional ISO calibration of the comparison plates**, SAUTER 961-170, € 95,-
- **Test stand** for HDA and HDO, SAUTER TI-A0L, € 270,-
- **Test stand** for HDD, SAUTER TI-DL, € 340,-

#### STANDARD

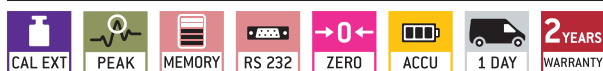

#### OPTION



Model	Hardness type	Measuring range	Readout	Price excl. of VAT ex works €
SAUTER		[Max] HS	[d] HS	
HDA 100-1.	Shore A	100 HA	0,1 HA	375,-
HDO 100-1.	Shore 0	100 H0	0,1 H0	375,-
HDD 100-1.	Shore D	100 HD	0,1 HD	375,-

# Manual shore test stand SAUTER TI



## Lever operated test stand for hardness testing with base plate made out of glass

### Features

- For Shore hardness testing of plastics, leather etc.
- **1 Glass plate:** Providing a higher base hardness and superior accuracy
- **2 Mechanical construction:** Robust design for precise measuring
- **3 Level adjustment:** For the precise levelling of the base plate, e.g. for the correction of inhomogeneous test objects
- **4 Test stand TI-DL,** with exchangeable longer column for use with digital hardness tester HD
- Hardness tester not included in delivery

### Operation:

1. The SAUTER hardness testing device HB or HD is fitted in a suspended position
  2. The test object is placed on the round testing table right under the durometer pin
  3. By lowering the handle lever, the measurement instrument is pressed in a controlled manner into the test object
- The accuracy of the displayed result is approx. 25 % higher than in a manual operated test
  - Large illustration with analogue Shore hardness tester SAUTER HB (not included)

### Technical data

- Stroke length: 15 mm
- Maximum test object height: 63 mm
- Base plate Ø 75 mm
- Overall dimensions WxDxH  
 TI-A0: 150x110x330 mm  
 TI-D: 150x110x400 mm  
 TI-A0L: 150x110x380 mm  
 TI-DL: 150x110x450 mm
- Net weight approx. 8,5 kg

STANDARD



Model	Suitable for	Length of column	Price excl. of VAT ex works €
<b>SAUTER</b>		mm	
TI-A0	HBA, HB0	245	<b>240,-</b>
TI-D.	HBD	245	<b>300,-</b>
TI-A0L	HDA, HD0	300	<b>270,-</b>
TI-DL	HDD	300	<b>340,-</b>

# HLD 223



## 07 Hardness testing of metals (Leeb)

Determining the hardness of metals is of particular significance during the preparation and use of metallic materials. Traditionally, hardness is determined using test machines in accordance with Vickers, Rockwell or Brinell.

Since 1978, a rebound test was used for the first time for mobile measuring, in accordance with Dietmar Leeb. To do this, a standardised impact body (such as SAUTER AHMO D01) is shot against the item to be tested. The rebound of the impact body leads to a deformation of the upper surface, which results in a loss of kinetic energy. This loss of energy is determined by measuring the speed and herefrom the Leeb hardness value (HL) is calculated.

These measuring devices can be used in any location. Usually they are equipped with a large internal data memory, which allows to record the measurements at goods receipt or in production.

Our range is equipped with compact measuring devices of the so-called "Pen Type" shape (HN-D) or measuring devices with external sensors connected by cables.



**Taras Mikitsin**  
Product specialist  
Hardness testing of metals

Tel. +49 [0] 7433 9933-143  
Fax +49 [0] 7433 9933-29143  
mikitsin@kern-sohn.com

### Quick-Finder

Readout	Sensor	Model	Price excl. VAT, ex works €	Page
[d] HL		<b>SAUTER</b>		
1	D	<b>HK-D.</b>	<b>1240,-</b>	56
1	D	<b>HK-DB.</b>	<b>1390,-</b>	56
1	D	<b>HMM.</b>	<b>1330,-</b>	57
1	D	<b>HMO.</b>	<b>1770,-</b>	58
1	D	<b>HN-D.</b>	<b>1290,-</b>	59

# Mobile Leeb hardness tester SAUTER HK-D · HK-DB



## Premium Durometer for hardness testing – now also with hardness comparison block included

### Features

- Measures all metal samples (> 3 kg, thickness > 8 mm)
- **External impact sensor** standard (Type D)
- **Mobility:** In comparison with stationary table-top devices and testing devices with an internal sensor, using the SAUTER HK-D, offers the highest level of mobility and flexibility
- **All measurement directions possible (360°)** thanks to an automatic compensation function
- **1 Hardness comparison block**, hardness 760 +/- 30 HLD, included in delivery (only at HK-DB!)
- **2** Delivered in a sturdy carrying case
- **Measurement value display:** Rockwell (Type A, B, C), Vickers (HV), Shore (HS), Leeb (HL), Brinell (HB)
- **Internal memory** for up to 600 data groups, with up to 32 values per group forming the average value of the group
- **Mini statistics function:** displays the measured result, the average value, the impact direction, date and time
- **USB interface**, included
- **Automatic unit conversion:** The measuring result is automatically converted into all specified hardness units

- **Function to set limits:** an optic and acoustic signal supports the measuring procedure
- **Matrix display:** Backlit multi-function display for all relevant functions at a glance
- **Robust metal housing**

### Technical data

- Precision: ± 1 % at 800 HLD
- Minimum sample radius (concave/convex): 50 mm (with support ring: 10 mm)
- Minimum sample thickness: 8 mm
- Dimensions WxDxH 132x82x31 mm
- Permissible ambient temperature -10 °C/40 °C
- Battery operation, batteries not standard 2 x 1.5 V AA, operating time up to 200 h
- Net weight approx. 0,45 kg

### Accessories

- **Data transfer software**, KERN SCD-4.0, € 150,-
- **Support rings** for secure positioning, SAUTER AHMR 01, € 320,-
- **Impact body** Type D, net weight approx. 5,5 g, hardness ≥ 1600 HV, tungsten carbide, Impact ball Ø 3 mm, in accordance with the standard ASTM A956-02, SAUTER AHMO D01, € 115,-

- **External impact sensor** Type C. Low energy sensor: requires only 25 % impact energy compared to type D, for testing tiny or light objects or the surface of hardened layer, SAUTER AHMR C, € 640,-
- **External impact sensor** Type D, SAUTER AHMO D, € 340,-
- **External impact sensor** Type D+15. Slim front section for holes, grooves or re-entrant surfaces, SAUTER AHMR D+15, € 640,-
- **External impact sensor** Type DC. Short impact sensor for tests in holes or hollowed objects, SAUTER AHMO DC, € 490,-
- **External impact sensor** Type DL, for very narrow surfaces (Ø 4,5 mm), SAUTER AHMR DL, € 1590,-
- **External impact sensor** Type G. High energy sensor: 900 % impact energy compared to type D, SAUTER AHMR G, € 1590,-
- **Connection cable** SAUTER HMO-A04, € 95,-
- **3 Test block** Type D/DC, Ø 90 mm (± 1 mm), net weight < 3 kg, hardness range 790 ± 40 HL, SAUTER AHMO D02, € 190,- 630 ± 40 HL, SAUTER AHMO D03, € 190,- 530 ± 40 HL, SAUTER AHMO D04, € 190,- 590 ± 40 HL, SAUTER AHMO G01, € 440,- 500 ± 40 HL, SAUTER AHMO G02, € 440,- **ISO calibration certificate** for SAUTER AHMO D02, AHMO D03, AHMO D04, SAUTER 961-132, € 120,-

#### STANDARD



#### OPTION



Model	Sensor	Measuring range [Max] HL	Readout [d] HL	Test block Typ D/DC approx. 800 HL	Price excl. of VAT ex works €	Option ISO Calibration Certificate	
						ISO KERN	€
SAUTER HK-D.	Type D	170 - 960	1	-	1240,-	961-131	120,-
SAUTER HK-DB. <small>NEW</small>	Type D	170 - 960	1	included	1390,-	961-131	120,-

NEW New model



# Mobile Leeb hardness tester SAUTER HMM

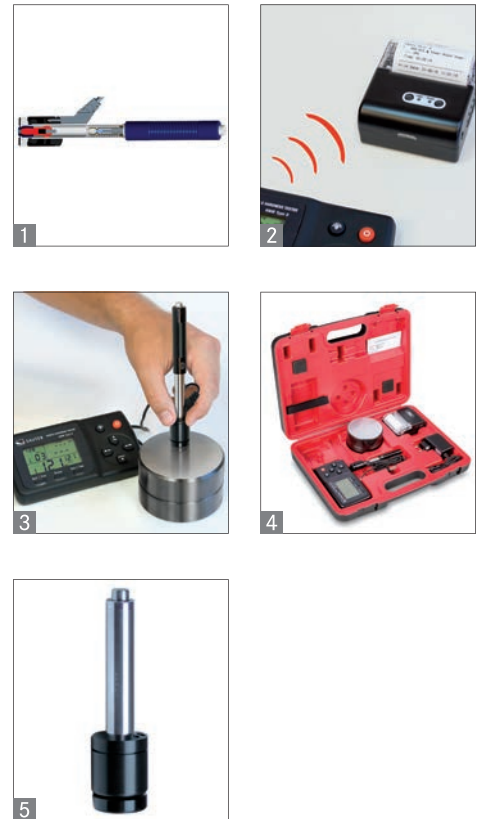

## Advanced features for demanding applications

### Features

- **1 Impact (rebound) sensor:** The bounce module is accelerated by a spring against the item being tested. Depending on how hard the object is, the kinetic energy of the module will be absorbed. The speed reduction will be measured and converted to Leeb hardness values.
- **External impact sensor (Type D)** included
- **Automatic recognition of the impact (rebound) sensor** connected to the HMM.
- **Mobility:** In comparison with stationary table-top devices and testing devices with an internal sensor, using the SAUTER HMM, offers the highest level of mobility and flexibility
- **All measurement directions possible (360°)** thanks to an automatic compensation function
- **2 Wireless IR printer** included for on-site printing of measurement protocols (battery operated), can be re-ordered, SAUTER AHN-02, € 340,-

- **3 Standard block for calibration** included (approx. 790 ± 40 HL)
- **4** Delivered in a hard carrying case
- **Internal memory** for up to 9 data groups, with up to 9 values per group forming the average value of the group
- **Mini statistics function:** displays the measured result, the average value, the impact direction, date and time
- **Measurement value display:** Rockwell (B & C), Vickers (HV), Brinell (HB), Shore (HSD), Leeb (HL), tensile strength (MPa)
- **Automatic unit conversion:** The measuring result is automatically converted into all specified hardness units

### Technical data

- Precision: 1 % at 800 HLD (± 6 HLD)
- Measuring range tensile strength: 375 - 2639 MPa (steel)
- Min. sample weight on a solid and stable support: 3 kg
- Minimum sample thickness: 8 mm

- Minimum sample radius (concave/convex): 50 mm (with support ring: 10 mm)
- Dimensions WxDxH 80x30x150 mm
- Mains adapter external standard
- Optional battery operation, batteries standard 3 x 1,5 V AAA, AUTO-OFF function to preserve the batteries, battery level indicator
- Net weight approx. 0,2 kg

### Accessories

- **5 External impact sensor** Type DC. Short impact sensor for tests in holes or hollowed objects, SAUTER AHMO DC, € 490,-
- **Attachment rings** for secure positioning, SAUTER AHMR 01, € 320,-
- **Impact body**, SAUTER AHMO D01, € 115,-
- **Test block** Type D/DC, Ø 90 mm (± 1 mm), net weight < 3 kg, hardness range 790 ± 40 HL, SAUTER AHMO D02, € 190,- 630 ± 40 HL, SAUTER AHMO D03, € 190,- 530 ± 40 HL, SAUTER AHMO D04, € 190,-
- **Paper roll**, 1 piece, for SAUTER AHN-02, SAUTER ATU-US11, € 15,-

#### STANDARD



#### OPTION



Model	Sensor	Measuring range	Readout	Price excl. of VAT ex works €	Option ISO Calibration Certificate	
					ISO KERN	€
SAUTER HMM.	Type D	[Max] HL 170-960	[d] HL 1	1330,-	961-131	120,-

# Mobile Leeb hardness tester SAUTER HMO

PREMIUM  
★★★

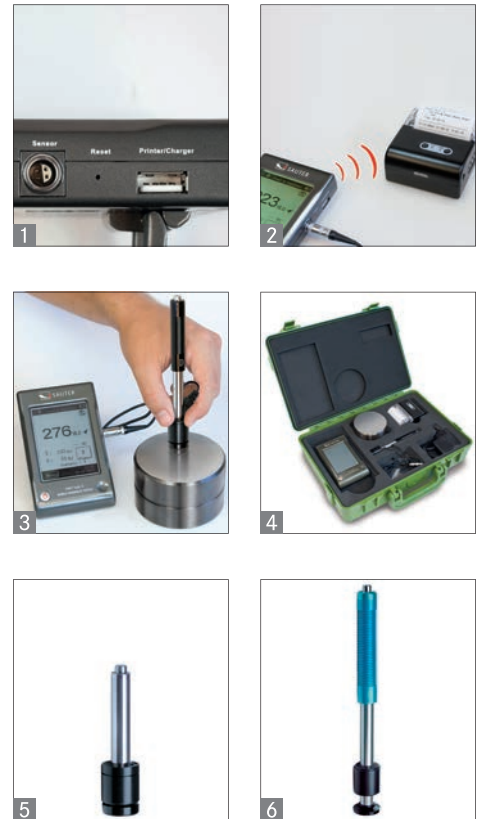

## Advanced features for professional applications

### Features

- **Innovative touchscreen**
- **Automatic recognition of the impact (rebound) sensor** connected to the HMO.
- **Mobility:** In comparison with stationary table-top devices and testing devices with an internal sensor, using the SAUTER HMO offers the highest level of mobility and flexibility
- **All measurement directions possible (360°)** thanks to an automatic compensation function
- **1 USB interface** for connection to the printer and charging the batteries
- **2 Wireless IR printer** included for on-site printing of measurement protocols (battery operated), can be re-ordered, SAUTER AHN-02, € 340,-
- **3 Standard block for calibration** included
- **4** Delivered in a hard carrying case
- **Internal memory** up to 800 values
- **Mini statistics function:** Displays the measure value, the average value, the difference between the maximum and minimum values, date and time

- **Measurement value display:** Rockwell (B & C), Vickers (HV), Brinell (HB), Shore (HSD), Leeb (HL), tensile strength (MPa)
- **Automatic unit conversion:** The measuring result is automatically converted into all specified hardness units

### Technical data

- Precision: 1 % 800 HLD ( $\pm 6$  HLD)
- Measuring range tensile strength: 375 - 2639 MPa (steel)
- Min. sample weight on a solid and stable support: Sensor D + DC: 3 kg  
Sensor G: 15 kg
- Minimum sample thickness: Sensor D + DC: 8 mm  
Sensor G: 10 mm
- Minimum sample radius (concave/convex): 50 mm (with support ring: 10 mm)
- Dimensions WxDxH 83x24x135 mm
- Operation by rechargeable battery pack, operating time up to 50 h, mains adapter included, can be re-ordered, SAUTER HMO-A03, € 75,-
- Net weight approx. 228 g

### Accessories

- **5 External impact sensor** Type DC. Short impact sensor for tests in holes or hollowed objects, SAUTER AHMO DC, € 490,-
- **6 External impact sensor** Type G. High energy sensor: 900 % impact energy compared to type D, SAUTER AHMO G, € 1710,-
- **Support rings** for bended testing samples available on request, SAUTER AHMR 01, € 320,-
- **Impact body**, SAUTER AHMO D01, € 115,-
- **Connection cable**, SAUTER HMO-A04, € 95,-
- **Test block** Type D/DC,  $\varnothing$  90 mm ( $\pm 1$  mm), net weight < 3 kg, hardness range 790  $\pm$  40 HL, SAUTER AHMO D02, € 190,-  
630  $\pm$  40 HL, SAUTER AHMO D03, € 190,-  
530  $\pm$  40 HL, SAUTER AHMO D04, € 190,-  
590  $\pm$  40 HL, SAUTER AHMO G01, € 440,-  
500  $\pm$  40 HL, SAUTER AHMO G02, € 440,-
- **Paper roll**, 1 piece, for SAUTER AHN-02, SAUTER ATU-US11, € 15,-

STANDARD



OPTION



Model	Sensor	Measuring range [Max] HL	Readout [d] HL	Price excl. of VAT ex works €	Option ISO Calibration Certificate	
					ISO KERN	€
SAUTER HMO.	Type D	170-960	1	1770,-	961-131	120,-

# Mobile Leeb hardness tester SAUTER HN-D



## “Pen type“ Leeb hardness tester for mobile hardness testing of metals

### Features

- **User-friendly operation:** The compact version enables the product to be used in a significantly wider range of applications compared with traditional devices
- The measuring device has been designed for one-hand operation and this allows the user to work more quickly and flexibly
- **Modern LCD display:** Optimised for industrial applications: increased luminosity and backlight can be switched on, that way the display can be read from any angle
- **All measurement directions possible (360°)** thanks to an automatic compensation function
- **Internal impact sensor** included (Type D)
- **Measurement value display:** Rockwell (B & C), Vickers (HV), Brinell (HB), Shore (HSD), Leeb (HL)
- **Hardness comparison block** not included
- **Internal data memory** for up to 500 measurements with date and time
- **USB-PC data output:** Easy to install on any PC
- Delivered in a hard carrying case

### Technical data

- Accuracy  $\pm 4$  HLD
- Dimensions WxDxH 35x25x145 mm
- Operation by rechargeable battery pack, standard
- Mains adapter, external, standard
- Net weight approx. 0,07 kg

### Accessories

- **PC software to download stored data**, for statistical evaluation, and transfer to Microsoft Excel, SAUTER AHN-01, **€ 115,-**
- **Attachment rings** for secure positioning, SAUTER AHMR 01, **€ 320,-**
- **Test block** Type D/DC,  $\varnothing$  90 mm ( $\pm 1$  mm), Net weight < 3 kg, hardness range 790  $\pm$  40 HL, SAUTER AHMO D02, **€ 190,-**  
630  $\pm$  40 HL, SAUTER AHMO D03, **€ 190,-**  
530  $\pm$  40 HL, SAUTER AHMO D04, **€ 190,-**
- **ISO calibration certificate** for SAUTER AHMO D02, AHMO D03, AHMO D04, SAUTER 961-132, **€ 120,-**
- **Thermal printer**, wireless infrared connection to SAUTER HN-D, HMM, HMO, SAUTER AHN-02, **€ 340,-**
- **Paper roll**, 1 piece, for SAUTER AHN-02, SAUTER ATU-US11, **€ 15,-**

#### STANDARD



#### OPTION



Model	Sensor	Measuring range	Readout	Price excl. of VAT ex works €	Option ISO Calibration Certificate	
					ISO KERN	€
SAUTER HN-D.	Type D	[Max] HL 0 - 999	[d] HL 1	<b>1290,-</b>	961-131	120,-



# HV 225



## 08 Hardness testing of metals (UCI)

Ultrasonic contact impedance (UCI) hardness testing devices are filling wisely a void in the area of hardness testing.

This area of testing is, on one hand, dominated by mobile hardness testing devices which are using the Leeb procedure and, on the other hand, by stationary hardness testing devices which are predominantly carrying out destructive tests.

Because of the high demands required by this system on the minimum weight and thickness of the test object, the Leeb procedure is not suitable for the majority of tests for small test objects. A good example of this is hardness testing of the flanks of gear wheels. Often in this test, the question is whether the flanks have been hardened or whether the hardened layer has already been removed.

UCI hardness testing devices therefore are offering significantly better measurement performance at small test objects in comparison with Leeb hardness testing devices.

One advantage of the UCI hardness testing devices compared with stationary hardness testing machines is, that the test object does not have to be cut out of the whole object.

By using the optional support rings, the minimum weight of the test object can even be reduced from 300 g to 100 g.

By means of optional ISO calibration, SAUTER UCI hardness testing devices can be used not only for internal testing purposes but also for measurements where the results have to be changed externally.



**Taras Mikitisin**  
Product specialist  
Hardness testing of metals (UCI)

Tel. +49 [0] 7433 9933-143  
Fax +49 [0] 7433 9933-29143  
mikitisin@kern-sohn.com

### Quick-Finder

Model	Hardness scale	Price excl. VAT, ex works €	Page
<b>SAUTER</b>			
HO 1K	HV 1	4500,-	61
HO 2K	HV 2	4500,-	61



# Mobile ultrasound hardness testing device SAUTER HO



**NEW** **PREMIUM** ★★ ★



## Premium UCI hardness testing device for Rockwell, Brinell and Vickers

### Features

- **Application:** This ultrasound hardness testing device is ideally suited for mobile hardness testing, where the main emphasis is on obtaining rapid and precise results.
- **Principle:** The SAUTER HO measures using a Vickers diamond tip, which is pressed into the test piece with a defined force. After that the tip is moved into high-frequency ultrasound vibrations. The hardness is derived from the attenuation
- **Examples:** The HO ultrasound hardness testing system is primarily used for measuring small forgings, castings, welding points, punched parts, casting tools, ball bearings and the flanks of gear wheels as well as for measuring the influence of warmth or heat
- **Advantages compared with Rockwell and Brinell:** Less test force and therefore only microscopic, small penetrations means that the testing is less destructive
- **Advantages compared with Vickers:** Demanding optical measuring is not required. You can therefore carry out measurements directly on-site, for example, on a permanently installed workpiece

- **Advantages compared with Leeb:** The high requirements for the weight of the test object are no longer required, in most cases
- **Standards:** The device fulfils these technical standards: DIN 50159-1-2008; ASTM-A1038-2005; JB/T9377-2013
- **2 Mini statistics function:** Display of the measuring result, the number of measurements, the maximum and minimum value as well as the average value and the standard deviation
- **Measurement data memory** saves up to 1000 measurement groups each with 20 individual values
- **Calibration:** The device can be adjusted to standard hardness comparison plates as well as to individual reference standards
- **1 Scope of delivery:** Display unit, UCI sensor unit, transport case, software to transfer the saved data to the PC, accessories

### Technical data

- Measuring ranges: HRC: 20,3–68; HRB: 41–100; HRA: 61-85,6; HV: 80–1599; HB: 76–618; Tensile strength: 255–2180 N/mm<sup>2</sup>
- Precision: ± 3 HV; ± 1,5 HR; ± 3 % HB

- Measurement time: 2 Sek
- Display units: HRC, HV, HBS, HBW, HK, HRA, HRD, HR15N, HR30N, HR45N, HS, HRF, HR15T, HR30T, HR45T, HRB.
- Rechargeable battery pack integrated, standard, operating time up to 12 h without backlight, charging time approx. 8 h
- Minimum weight of the test object: 300 g for direct measurement with the sensor (included); 100 g with supporting ring (optional)
- Minimum thickness of the test object: 1 mm
- Minimum dimensions of the test surface size around: approx. 5 x 5 mm (recommended)
- Overall dimensions WxDxH 160x83x28 mm
- Permissible ambient temperature -10 °C/40 °C
- Net weight approx. 0,7 kg

### Accessories

- **3** Support ring, flat, SAUTER HO-A04, € 390,-
- **4** Support ring, small cylinder, SAUTER HO-A05, € 390,-
- **5** Support ring, large cylinder, SAUTER HO-A06, € 390,-
- **6** Deep-hole protective cover, SAUTER HO-A07, € 220,-

#### STANDARD



#### OPTION



Model	Hardness scale	Price excl. of VAT ex works €	Option ISO Calibration Certificate	
			ISO KERN	€
SAUTER HO 1K	HV 1	4500,-	961-270	260,-
HO 2K	HV 2	4500,-	961-270	260,-

db 42



## 09 Occupational safety/Environment

Prevention of accidents as well as modern health care have got the same operational starting point in many countries. With industrialisation and the development of cities, regular preventive medical examinations were introduced for wide sections of the population.

Up to now, occupational health and safety in the sense of accident prevention has – essentially – become a real part of operational responsibility.

For this purpose, SAUTER provides the two most commonly-used instruments in general measuring technology. They can be used to measure environmental influences such as noise (acoustic pressure) or light.

Furthermore we can offer a practical carrying case, for a safe transport of all devices (MPS-A07, € 115,- please refer to [www.sauter.eu](http://www.sauter.eu) for more details).

For regular calibration, our pick-up and return service can be used, which will save you a lot of efforts and expenses.



**Taras Mikitisin**  
Product specialist  
Occupational safety/Environment

Tel. +49 [0] 7433 9933-143  
Fax +49 [0] 7433 9933-29143  
[mikitisin@kern-sohn.com](mailto:mikitisin@kern-sohn.com)

### Quick-Finder

Readout	Measuring range	Model	Price excl. VAT, ex works €	P.
[d]	[Max]	SAUTER		
0,1 1 10 100 lx	200 2000 20000 200000 lx	<b>SO 200K.</b>	<b>85,-</b>	63
0,1 dB	130 dB	<b>SU 130.</b>	<b>110,-</b>	64

# Light measuring instrument SAUTER SO



Light measuring instrument for precise light measurement up to 200,000 Lux

## Features

- Measures illumination in the workplace
- Helps to determine whether a workstation has insufficient light or whether there is too much light
- **Photo sensor:** silicon diode
- **Cosine correction** for angular incident light
- **Sturdy protective cover** for the photo sensor
- **Increased service life:** Impact protection through a protective casing
-  Delivery in a robust box
- **Track function** for continuous recording of variable environmental conditions
- **Peak Hold Mode** to capture peaks
- Selectable measuring units: fc (foot-candle), lx

## Technical data

- Measuring frequency: 2 Hz
- Cable length (Photo sensor) approx. 1 m
- Dimensions WxDxH 100x60x28 mm
- Optional battery operation, battery not standard (9 V Block), AUTO-OFF function to preserve the battery
- Net weight approx. 250 g

### STANDARD



### OPTION



Model	Measuring range	Readout	Price excl. of VAT ex works €	Option ISO Calibration Certificate	
				ISO KERN	€
SAUTER	[Max] lx	[d] lx	85,-	961-190	165,-
SO 200K.	200	0,1			
	2000	1			
	20000	10			
	200000	100			

# Sound level meter SAUTER SU



## Professional sound level meter, Class II

### Features

- **Professional sound level meter** for measuring noise in areas such as, for example, the environment, mechanical applications, car industry and much more
- Measures the sound intensity in the workplace
- Helps in differentiating between normal noise influences, and excessive noise, e.g. in a production hall
- **1 Data interface RS-232**, included
- **2** Delivered in a hard carrying case
- **Multi measuring functions:**
  - Lp: Standard sound level measuring function
  - Leq: Energy equivalent sound level measuring mode (type A)
  - Ln: Shows the deviation from a pre-defined limit in %

- Selectable methods of evaluation:
  - A: As sensitive as the human ear
  - C: Sensitive for noisier environmental conditions, where there are machines, plant, motors etc.
  - F: For areas where sound intensity does not vary
- **Function to set limits:** Programmable target value for go/no-go test values
- **Track function** for continuous recording of variable environmental conditions
- **Peak Hold Mode** to capture peaks
- **Internal memory for measured values**, for 30 measurements. Can be displayed on the PC

### Technical data

- Dimensions WxDxH 236x63x26 mm
- Battery operation, batteries not standard 4 x 1.5 V AAA
- Net weight approx. 170 g

### Accessories

- **Data transfer software**, interface cable included, SAUTER ATC-01, € 90,-
- **Adjustment device** for regular adjustment of the sound level meter, SAUTER ASU-01, € 260,-
- **Foam plastics protective cover**, SAUTER ASU-02, € 5,-

STANDARD



OPTION



Model	Type	Measuring range	Readout	Price excl. of VAT ex works €
SAUTER		[Max] dB	[d] dB	
SU 130.	Lp A	30 - 130	0,1	110,-
	Lp C	35 - 130		
	Lp F	35 - 130		



**DAkkS calibration certificate for force gauges (extract)**  
 Further details on the internet [www.kern-lab.com](http://www.kern-lab.com)

**KERN** KERN & Sohn GmbH  
 Älteste europäische Feinwaagen und Gewichtfabrik seit 1844  
 Oldest European Manufacturer of Precision Balances since 1844

akkreditiert durch die / accredited by the  
**Deutsche Akkreditierungsstelle GmbH**  
 als Kalibrierlaboratorium im / as calibration laboratory in the  
**Deutschen Kalibrierdienst DKD**

Kalibrierschein / Calibration certificate  
 Kalibrierzeichen / Calibration mark

Objekt / Force gauge  
 Hersteller / KERN & Sohn GmbH  
 Typ / FH 500  
 Auftragsgeber / Mustermann GmbH

Messwerte (Zug) / Measurement results (tension force)

Kraft / force	Ausgangsposition / initial position				120°				240°			
	R1	R2	R3	R4	R5	R6	R7	R8	R9	R10	R11	R12
0 N	0,0 N	0,0 N	0,0 N	0,0 N	0,0 N	0,0 N	0,0 N	0,0 N	0,0 N	0,0 N	0,0 N	0,0 N
98,063 N	98,1 N	98,1 N	98,2 N	98,1 N	98,1 N	98,1 N	98,1 N	98,1 N	98,1 N	98,1 N	98,1 N	98,1 N
196,126 N	196,2 N	196,3 N	196,4 N	196,2 N	196,2 N	196,3 N	196,2 N	196,3 N	196,2 N	196,2 N	196,2 N	196,2 N
294,189 N	294,3 N	294,3 N	294,5 N	294,3 N	294,3 N	294,3 N	294,3 N	294,3 N	294,3 N	294,3 N	294,3 N	294,3 N
392,251 N	392,4 N	392,4 N	392,6 N	392,4 N	392,4 N	392,4 N	392,4 N	392,4 N	392,4 N	392,4 N	392,4 N	392,4 N
490,313 N	490,4 N	490,5 N	490,6 N	490,6 N	490,6 N	490,6 N	490,6 N	490,4 N	490,4 N	490,4 N	490,4 N	490,4 N
0 N	0,0 N	0,0 N	0,0 N	0,0 N	0,0 N	0,0 N	0,0 N	0,0 N	0,0 N	0,0 N	0,0 N	0,0 N

Messergebnisse (Zug) / Measured values (tension force)

rel. Kalibrierabweichung: 0,000 %  
 rel. Nullpunktabweichungen: 0,000 % (R1), 0,000 % (R2), 0,000 % (R3/R4), 0,000 % (R5/R6)

Kraft / force	arith. Mittelwert / average	rel. Wiederhol- precision b/ repeatability	rel. Vergleichs- precision b/ reproducibility	rel. Umkehrspanne v/ hysteresis
98,063 N	98,1 N	0,000 %	0,102 %	0,051 %
196,126 N	196,3 N	0,051 %	0,102 %	0,078 %
294,189 N	294,4 N	0,000 %	0,068 %	0,034 %
392,251 N	392,4 N	0,000 %	0,076 %	0,025 %
490,313 N	490,5 N	0,020 %	0,041 %	0,000 %

KERN	Measurand	Measuring range	Price excl. VAT, ex works €
<b>DAkkS Calibration</b>			
963-161	Force (Tension)	500 N	250,-
<b>ISO-Kalibrierung</b>			
961-161	Force (Tension)	≤ 500 N	135,-
961-162	Force (Tension)	≤ 2.000 N	165,-
961-163	Force (Tension)	≤ 10.000 N	225,-
961-164	Force (Tension)	≤ 20.000 N	350,-
961-165	Force (Tension)	≤ 50.000 N	520,-
961-166	Force (Tension)	≤ 100.000 N	940,-
961-261	Force (Compression)	50 – 500 N	135,-
961-262	Force (Compression)	≤ 2.000 N	165,-
961-263	Force (Compression)	≤ 5.000 N	225,-
961-361	Force (Tens. and Comp.)	≤ 500 N	245,-
961-362	Force (Tens. and Comp.)	≤ 2.000 N	300,-
961-363	Force (Tens. and Comp.)	≤ 5.000 N	405,-
961-167	Force (for hand grip dynamometer SAUTER MAP)	≤ 130 kg	120,-
961-110	Coating thickness	≤ 2.000 µm F or N	120,-
961-112	Coating thickness	≤ 2.000 µm FN	170,-
961-113	Wall thickness (ultra sound)	≤ 300 mm (in stainless steel)	120,-
961-114	Wall thickness (test blocks)	≤ 300 mm	150,-
961-170	Hardness Shore	For sets up to 7 plates	95,-
961-131	Hardness Leeb	400 – 800 HLD	120,-
961-132	Hardness Leeb	Test block (for Leeb durometer)	120,-
961-270	Hardness UCI	200 – 800 HV	260,-
961-150	Length	≤ 300 mm	120,-
961-190	Light	≤ 200.000 lx	165,-
961-100	Weight (Mechanical balances/ Spring balances)	≤ 5 kg	72,-
961-101	Weight (Mechanical balances/ Spring balances)	> 5 – 50 kg	88,-

## The advantages of using KERN in-house calibration

- **Quick calibration:** duration four working days only
- **Competence:** Laboratory meets the highest metrological standards (for mass)
- **Keeping recalibration calendar** for your individual instrument
- **Universal use:** Calibration possible for variety of instruments shown in catalogue

## Recalibration

- **Typical industrial recalibration times** may be recommended as follows:
  - daily use (once or several times): Recalibration times: 12 months
  - weekly use (or less frequent use): Recalibration times: 24 months
- **Recalibration prices:** The prices for initial calibration and recalibration are identical (see the table shown here). Costs for cleaning or for the production of special holders to carry out the calibration will be calculated separately, if required.

# Retailer information

## Sales conditions



**All prices are valid as of January 1st 2016** until a new version of the SAUTER catalogue is released. In Europe, all prices do not include the applicable V.A.T.

**At SAUTER there is no minimum order value.** For orders less than € 15.00 there is no re-sale discount available. A minimum fee of € 15.00 will be charged for orders less than € 15.00 (net).

**Delivery Conditions:** we supply ex works Balingen, i.e. the transport costs are invoiced. Any goods supplied, remain SAUTER's property until complete payment for the goods sold has been received.



Delivery is usually via courier service.



When you see this symbol by truck, please ask for prices.

### Extract from general terms and conditions:

Court of jurisdiction/Legal domicile: 72336 Balingen, Germany;  
Commercial register N°: HRB 400865, AG Stuttgart;  
Managing director: Albert Sauter, Martin Sauter.  
For the full Terms and Conditions, please refer to the website.  
[www.kern-sohn.com/en/kern/agbs.html](http://www.kern-sohn.com/en/kern/agbs.html)

**Price changes and product changes** are likely in individual cases due to product modifications as well as error.

**Sale or return:** within 14 days of purchase. Not valid for order-specific adaptations such as special productions, cable extensions, special weights, etc. or test services such as calibration etc. Depending on the time and effort involved, there may be processing and storage costs, please ask for details.

**Warranty:** 2 years. (Does not apply to consumables such as batteries, rechargeable battery packs, etc.)

## Services



**Free delivery:** all orders from dealers through the SAUTER online shop with an order value over € 150.00 (list price and parcel shipment, within the EU (except of MT, CY), with our parcel service, no pallet shipment) are delivered free of charge.

**3 % web discount:** Additional discount for dealer orders from the SAUTER online shop (only in combination with SAUTER e-invoice, please ask for details).

**KERN DirectCash:** The quick, secure COD procedure for protection against non-payment. With the KERN DirectCash COD system, you can safely deliver orders to end customers with unknown credit rating, with no risk of non-payment. Please request further details on this procedure.

## Hire Purchase

Financing is available using KERN hire purchase – easy and convenient.

Hire Purchase gives you the option of purchasing any product from the range against a simple monthly installment. The product value is financed over the period of the agreement. On payment of the last installment, the ownership of the contract item automatically transfers from the contractor to the contractee.

The Hire Purchase Agreement can – if you so choose – be set for a period of between one and five years. This package includes the transfer of items as well as the guarantee for the entire transfer period.

Compared with buying the product, KERN hire purchase offers the advantage that the initial financial investment is largely unnecessary. This is particularly relevant when purchasing a number of products, for example when refitting a laboratory, a company department or a hospital ward. In addition the monthly installments constitute a direct cost and the item does not have to be capitalised by the purchaser.

## After-Sales-Service



**Repair services** within 1 week at our plant in Balingen, transportation costs are additional. In urgent cases, if requested by customer, a replacement device will be provided until all repairs are completed; please ask.

**Price reduction on a new device:** if repair costs exceed the current value of the defective device, a new device will be offered at a discount price. This offer is valid only up to 2 years after warranty expiration.

**Spare parts service** within 48 hours, transportation costs are additional.

## Marketing support



### Catalogues, brochures, branch prospectuses – your own personalised marketing tools

Our catalogue and branch prospectuses are available free of charge. A neutral version of the catalogue, without the SAUTER address imprint, is also available for your marketing activities free of charge (100 pcs.), larger quantities on request..

On demand we will print your company address on address labels free of charge, for the backside of the catalogue (200 pcs.), larger quantities on request. In this way you will receive your individual marketing tool.

Our catalogues and branch prospectuses are available in the following languages: DE, GB, FR, IT, ES

Visit us our online shop: [www.sauter.eu](http://www.sauter.eu)

### Online-Shop

At your disposal round the clock. Delivery and service through your specialist dealer.

### Measuring instruments Quick-Finde

Find the product you want with the “Measuring instruments Quick-Finder” in no time.

### Calibration

In our accredited DAkks calibration laboratories, we produce internationally recognised DAkKS and ISO calibration certificates for balances and test weights as well as measuring instruments.



### Special offers

Special offers, special models and opportunities – something for everybody and always up to date – just drop in!

### One-Stop-Shopping

From force gauge to test stand – everything from one supplier.

### Downloads

For each model there is an individual brochure, user manual or pictures.